

masibus®

User's Manual
LOOP CALIBRATOR
LC-12



Masibus Automation & Instrumentation Pvt. Ltd.

B/30, GIDC Electronics Estate,

Sector-25, Gandhinagar-382044, Gujarat, India

☎ +91 79 23287275-79 📠 +91 79 23287281-82

Email: support@masibus.com

Web: www.masibus.com

Contents

1. Introduction	4
Foreword	4
Notice	4
Trademarks	4
Safety	4
General	5
warnings	5
Electrical warnings	5
Cautions	5
Summary of functions	6
2. LC-12 Hardware Parts & Accessories	7
2.1 Unpacking & Inspection	7
2.2 Operational Sections and Connections	7
2.2.1 The Terminal Connections	8
2.2.2 The KeyPad	12
2.2.3 The Display	13
2.2.4 The USB Connection.....	13
2.2.5 Stand for Table Top Use	13
2.3 Power Options	14
2.4 Battery	14
.....	14
2.4.1 Charge times.....	14
2.4.2 Operating Time	15
3. Start Up & Basic Operations	16
3.1 Power ON or OFF	16
3.2 The User Interface	16
3.2.1 The Status Bar	18
3.2.2 The Function key Bar	19
3.2.3 Display Mode	19
3.2.4 Display Operations	23

4. Menu Layout	28
4.1 MENU page	28
4.2 MEASURE Page	28
4.2 SOURCE Page	30
4.2.1 STEP Page	31
4.2.2 RAMP Page	33
4.3 DISPLAY Page.....	35
4.3.1 Measure Display Settings.....	35
4.3.2 Source Display Settings	37
4.3.3 Swtich Test Settings.....	38
4.4 DATA LOGGING Page	39
4.5 ALARM Page.....	41
4.6 SETTING Page	42
4.6.1 HART Settings	43
4.6.2 Display Settings	43
4.6.3 Date/Time Settings.....	43
4.6.4 Calibration	44
4.6.5 Battery Info.....	48
4.6.6 Set Password	48
4.6.7 Factory Reset.....	48
4.6.8 About Calibrator	48
5. Maintenance & Troubleshooting.....	49
5.1 Common Problems.....	49
5.2 Replacing the Battery.....	49
6. General Specifications	50
6.1 General Specifications	50
6.2 Measurement Parameters and Accuracy.....	51
6.3 Source Accuracy	51
6.4 Testing Features.....	51
6.5 Enclosure Dimensions	52

1. Introduction

Foreword

Thank you for purchasing Loop Calibrator LC-12. The LC-12 calibrator is compact hand-held calibrator with an easy to use graphical user interface. This manual describes the basic functions and operation methods. Please read through this user's manual carefully before using the product

Notice

The contents of this manual are subject to change without notice as a result of continuous improvements to the instrument's performance and functions.

Every effort has been made to ensure accuracy in the preparation of this manual. Should any errors or omissions come to your attention, however, please inform MASIBUS Sales office or sales representative. Under no circumstances may the contents of this manual, in part or in whole, be transcribed or copied without our permission.

Trademarks

The contents of this manual are subject to change without notice as a result of continuous improvements to the instrument's performance and functions.

Every effort has been made to ensure accuracy in the preparation of this manual. Should any errors or omissions come to your attention, however, please inform MASIBUS Sales office or sales representative. Under no circumstances may the contents of this manual, in part or in whole, be transcribed or copied without our permission.

Safety

Before you use the instrument, make sure that you read and understand all the related data. This includes: the applicable local safety procedures, this publication, and the instructions for the accessories/ options/ equipment you are using it with.

General warnings

WARNING

It is dangerous to ignore the specified limits for the instrument or its related accessories.

Do not use the instrument or accessory if it is not in its normal condition.

Use the applicable protection and obey all safety precautions.

Do not use the instrument in locations with explosive gas, vapor or dust. There is a risk of an explosion

Electrical warnings

To prevent electrical shocks or damage to the instrument, do not connect more than 30V between the terminals, or between the terminals and the ground.

This instrument uses a Lithium-Ion battery pack. To prevent an explosion or fire, do not short circuit, do not disassemble, and keep it safe from damage. For operating conditions, see section 6.1 on Page-50

To prevent battery leakage or heat generation, only use the battery charger in the temperature range 0 to 45°C (32 to 113°F). For operating conditions, see section 6.1 on Page-50.

To make sure the display shows the correct data, disconnect the test leads before you set the power to on or change to another measure or source function.

Cautions

To prevent damage to the display, do not use sharp objects on the screen.

Before you start an operation or procedure in this publication, make sure that you have the necessary skills (if necessary, with qualifications from an approved training establishment). Follow good engineering practice at all times.

Summary functions

of This table gives a summary of the available functions with the LC-12 calibrator.

Function
Easy to read liquid crystal display (LCD) in color
Rechargeable lithium Ion battery with enhanced power control for prolonged battery life.
* Measure current (mA, mA(24V)), voltage (Volt, mV)
* Supply current (mA, mA(2W)), voltage (Volt, mV)
Step/Ramp functions: Automatic/Manual
Switch test and condition indicator (open/closed)
Universal Serial Bus (USB) communications ports: For computer communications, & Battery Charging
Data Logging.
Other functions: Maximum / Minimum / Average, filter, tare, adjustable backlight, alarm indication (on the display and buzzer), automatic Display off.

2. LC-12 Hardware Parts & Accessories

2.1 Unpacking & Inspection

At the factory each new LC12 passes a careful inspection. It should be free of scrapes and scratches and in proper operation order upon receipt. The receiver should, however, inspect the unit for any damage that may have occurred during transit. If there are signs of obvious mechanical damage, package contents are incomplete, or the instrument does not operate according to specifications, contact the purchasing sales office as soon as possible.

The standard accessories are as follows:

- ✓ Calibration Certificate
- ✓ User Guide
- ✓ 2 Sets of 2mm to 2mm banana cable.
- ✓ 2 Sets of 2mm Crocodile clips.
- ✓ 2 Sets of connecting plug 4mm to 2mm
- ✓ USB A Male to USB mini B Male cable for PC communication and charging.
- ✓ 5 VDC Charging Adaptor
- ✓ Carrying Bag
- ✓ LC-12 Configuration & Logging Software CD-mCAL.

If you have to return the instrument to the factory for any reason, use the original packing whenever possible. Include a detailed description of the reason for the return.

2.2 Operational Sections and Connections

All sections and connections are presented in detail on the next pages.

Note: Keep in mind that the next picture (as well as all pictures of LC-12 in this manual) has an example configuration of modules. The configuration of your LC-12 may vary significantly from the one in the picture.



1	Terminal Connection For Measure & Source
2	Keypad Section
3	Color Display
4	USB Connection Slot for PC Communication & Charging

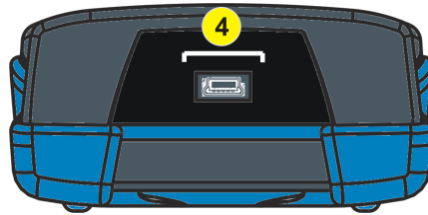

2.2.1 The Terminal Connections

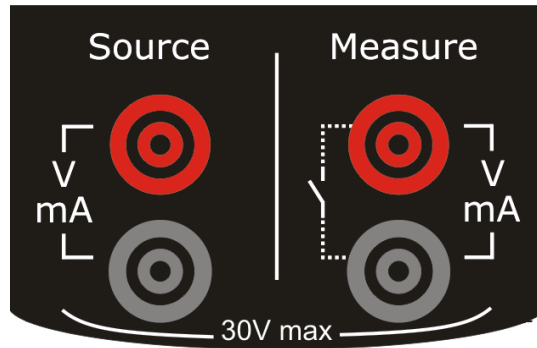

Source Terminals	
mA	Range: 0.000 – 24.000 mA Resolution: 0.001 mA
mA(2W)	Range: 0.000 – 24.000 mA Resolution: 0.001 mA
mV	Range: 0.00 – 250.00 mV Resolution: 0.01 mV
V	Range: 0.000 – 12.000 V Resolution: 0.001 V

- **Current Generation**

LC-12 is able to generate current both in source and sink mode. In source mode LC-12 provides the supply power to the loop. In sink mode an external power supply is used and LC-12 controls the current flow.

The following picture displays the connection for current source for different mode.

- **mA Current Source**

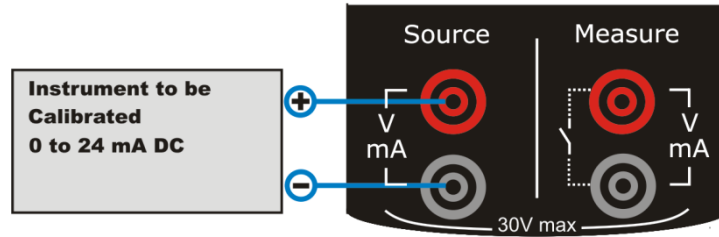

- **mA 2-Wire Simulation**

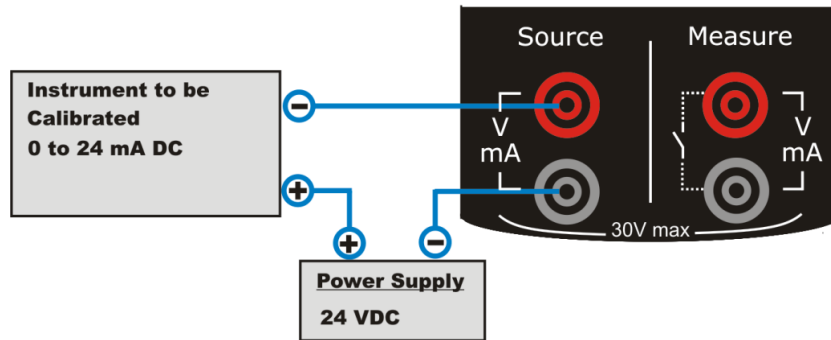

- **Voltage Generation**

LC-12 is capable of voltage generation with two voltage generation ranges.

The following picture displays the connection for voltage source for both mV & V Output Type.

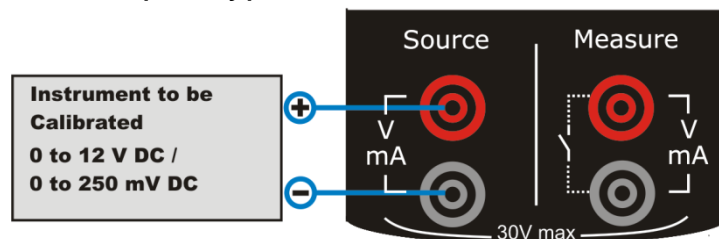

Measure Terminal	
mA	Range: 0.000 – 24.000 mA Resolution: 0.001 mA
mA(24V)	Range: 0.000 – 24.000 mA Resolution: 0.001 mA

mV	Range: 0.000 – 250.00 mV Resolution: 0.01 mV
V	Range: 0.000 – 30.000 V Resolution: 0.001 V
Switch Test	<ul style="list-style-type: none"> • Potential free contacts Trigger level : 24V, 24mA (2V) • Voltage level detection Trigger level : 0 to 30V in 1V steps Input impedance : >1MΩ

- **Current Measurement**

LC-12 supports current measurement using either LC-12 as the loop power supply while at the same time measuring the current or simply measuring the current while an external power supply is used.

The following picture displays the connection for Current Measurement for different mode. And also different ways of providing the supply power to the loop.

- **mA Current Measurement**

In this mode LC-12 not providing any supply voltage. For proper measurement the external device should capable of providing the voltage supply. If the external device should not capable, an external Power Supply should be connected in series.

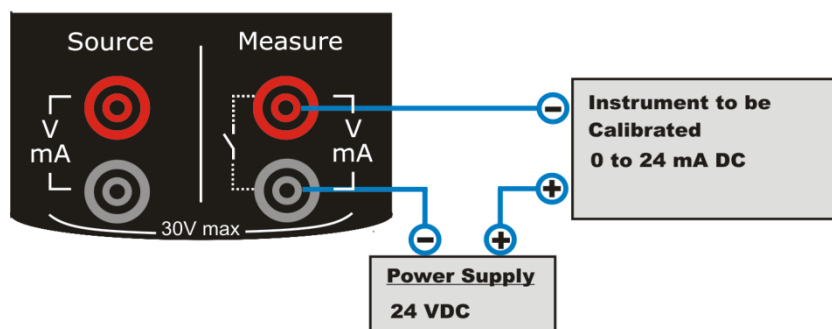
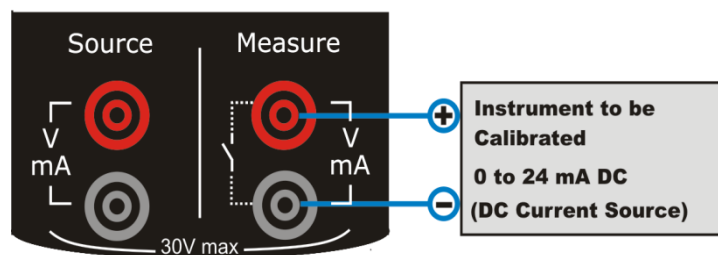

➤ mA Read Power Current Measurement

In this mode LC-12 works as Loop Power Supply while at the same time measuring the current.

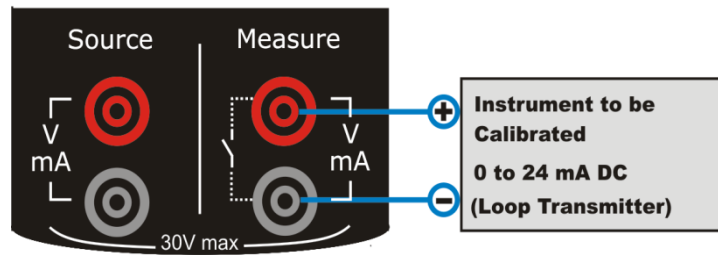

• Voltage Measurement

LC-12 is capable of voltage Measurement with two voltage measurement ranges.

The following picture displays the connection for Voltage Measurement for different mode.

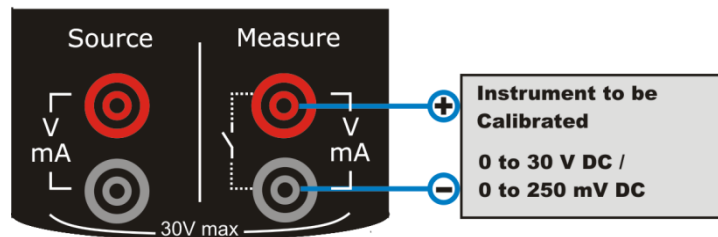

• Switch Test

LC-12 is capable of detecting switch's state both. When the switch is free of external potential or switches with DC voltages within the range 0 V to +30 V.

➤ Switch Mode : 2V(24Vdc,30mA)

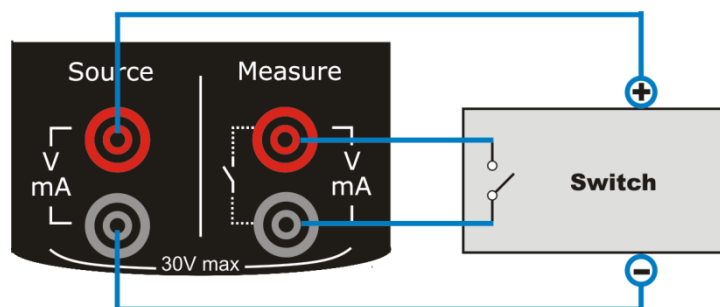



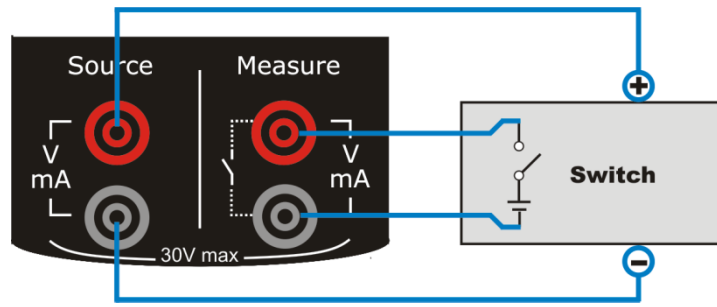

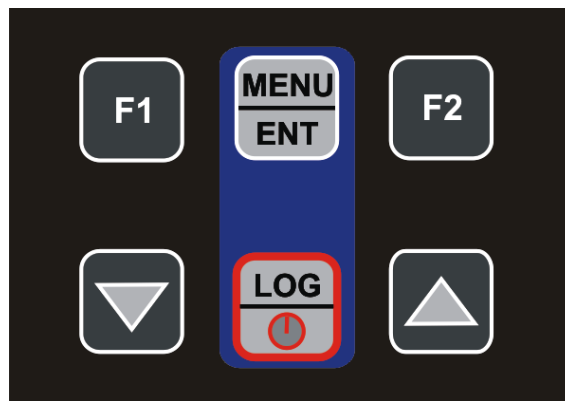

➤ Switch Mode : Voltage Trigger



2.2.2 The Keypad



LC-12 has six different keys. The key description is given below.

	This key has different functionalities in different menu. And that is shown on Bottom Left Part of Display.
	This key has different functionalities in different menu. And that is shown on Bottom Right Part of Display.
	This key is use to scroll down to the next parameter. And also for decrementing the value of digit in Editbox.
	This key is use to scroll up to the previous parameter. And also for incrementing the value of digit in Editbox.
	This Key is use for Entering into the MENU Page from Run Page. And Also for Saving Edited Parameter to the memory.
	This key is use to log current reading in memory if device is on Run Page & Log Mode is Manual. (In other Page than Run Mode, this key is use to come directly to Run Page. Long presses (Approx 2 Sec) on this key will ON-OFF the Unit.

2.2.3 The Display

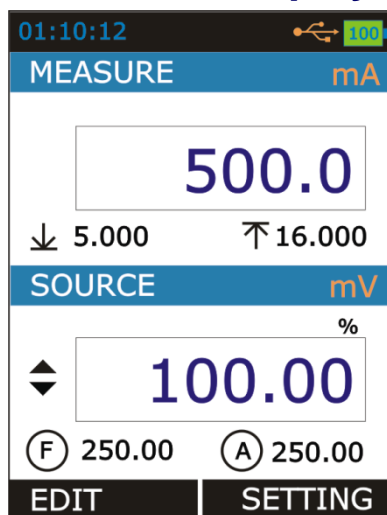



- This is a LCD with a 2.4” color display.
- The display has resolution of 240x320 pixels supporting 262K colors
- Refer section 3.2.3 on Page-19 or more detail

2.2.4 The USB Connection

- The USB Connection Connector is given at Top of the LC-12. It's a USB mini B-Type Female Connector.
- It is common for PC Communication & Charging the device.
- The USB cable given with the device is USB A-type Male to USB B-type male. It's common for connecting Charger & PC.

2.2.5 Stand for Table Top Use

- This Stand would offer the best support for table top use which gives good viewing angle when UC12 is placed table top
- Procedure to Open Stand
 -  is being engraved on the top of the stand. You should pull a bit first.
 -  is being engraved on the bottom of the stand. Now during first pull of above you can release this lower part easily so that you can maneuver the stand as you like.

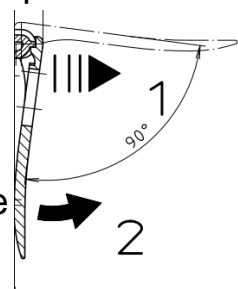

2.3 Power Options

There are three power options:

- **Lithium-Ion battery:** All the instrument functions are available with a charged battery.
- **5 V DC Charging Adaptor:** It supplies power to the instrument and charges the battery at the same time. It charges the battery when the instrument is on or off.
- **USB mini Type B connection:** This charges the battery when the instrument is off and increases the battery life when the instrument is on.

2.4 Battery

The Device uses 2300mAh Lithium-Ion Battery.

WARNING

- **To prevent an explosion or fire, do not short circuit, do not disassemble, and keep it safe from damage.** For operating conditions, see section 6.1 on Page-50.
- **To prevent an explosion or fire, use only the Masibus specified battery, battery charger & USB Cable.**
- **To prevent battery leakage or heat generation, only use the battery charger in the temperature range 0 to 45°C (32 to 113°F).** For operating conditions, see section 6.1 on Page-50.



When you set the power on, the battery symbol at the top of the display shows the charge Status. To get more information on Battery go to Battery Info Page in Setting Menu.

2.4.1 Charge times

Charge Method	Charge Time (to Full Capacity)
External Charging Adaptor	≈ 5 hours
USB mini Type B connector	≈ 6 hours (with 500mA Supply) (When device is Off)

Note:

USB mini Type B connector charges the battery when the instrument is off and increases the battery life when the instrument is on.

2.4.2 Operating Time

Operation	Battery Duration
Continuous operation (measure)	> 18 hours
Continuous operation (measure a source(@12mA))	> 8 hours

These are typical operating times for a new, fully charged Li-Ion battery pack with these settings:

- *Backlight Intensity* set to 5% (Default: 100%)
- *Backlight Timeout* set to 0 (0=Infinite) (Default: 0)

Power save options: To get the best battery duration, set a low value for the *Backlight Intensity* (40%) and a short *Timeout*.

The maximum operating time without recharging varies depending on the usage and brightness setting of the display light. Also the generated output current and the usage of the 24V transmitter supply affect the maximum operating time.

Notes:

- *LC-12's memory and the internal clock/calendar use a small amount of power although the calibrator is switched off. Remember to check the capacity of the batteries from time to time although LC-12 is not in use.*
- *Do not leave LC-12 without a Battery Pack or an Empty Battery for a long time. LC-12 may lose its settings if it is left without a support voltage for an extended period.*

3. Start Up & Basic Operations

3.1 Power ON or OFF

To set the instrument power ON, press and release this button down until the display comes on. During the power on sequence, the instrument shows a Startup Message and then shows the applicable data.

To set the instrument power off, press and hold (≈ 2 seconds) this button again. When the power is off, the last set of configuration options stays in memory

3.2 The User Interface

Every time LC-12 is switched on, the startup message ends in RUN Page.

There are 4 Display Mode available in RUN Page.

1. Measure + Source
2. Measure Only
3. Source Only
4. Switch Test + Source

This Display Mode can be selected from MENU \rightarrow DISPLAY Page.

In case of Dual Mode Display Screen is divided into two parts. Due to that only few additional info will appear on RUN Page. But Which Information to be shows can be selectable in Display Mode Menu. Refer Section 3.2.3 on Page-19 for more info.

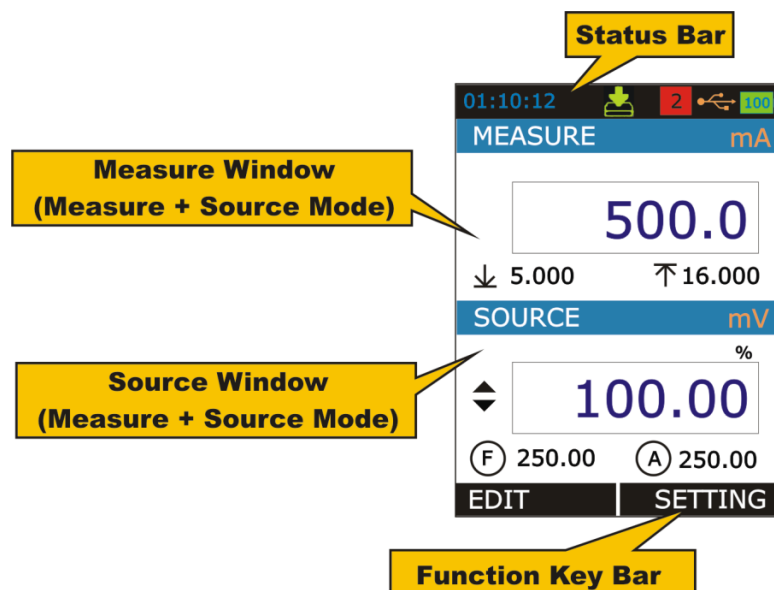

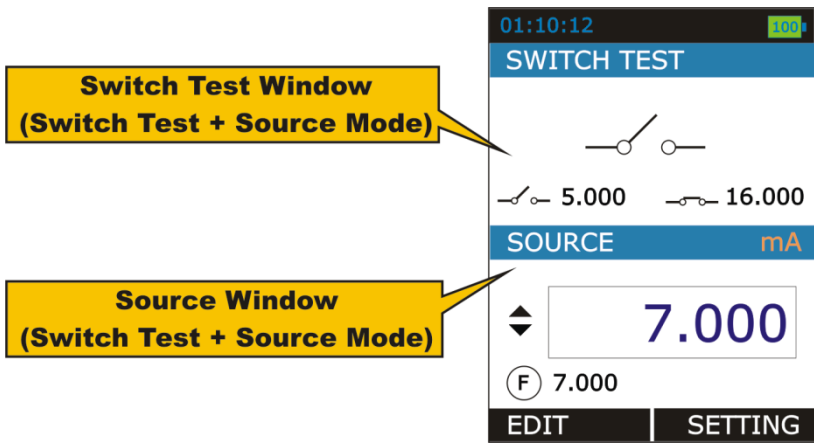
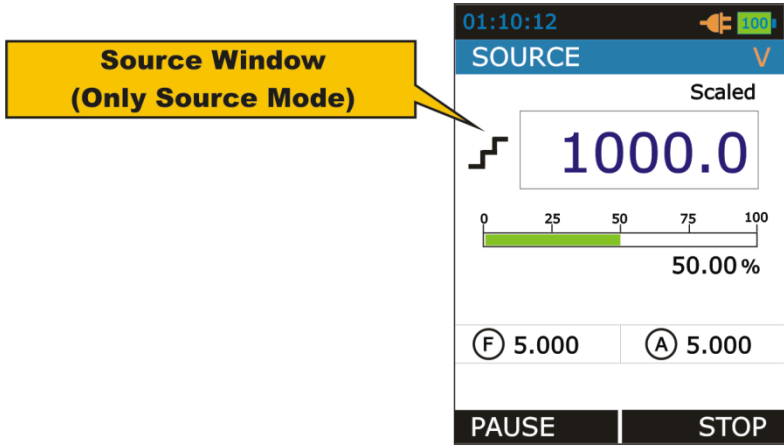
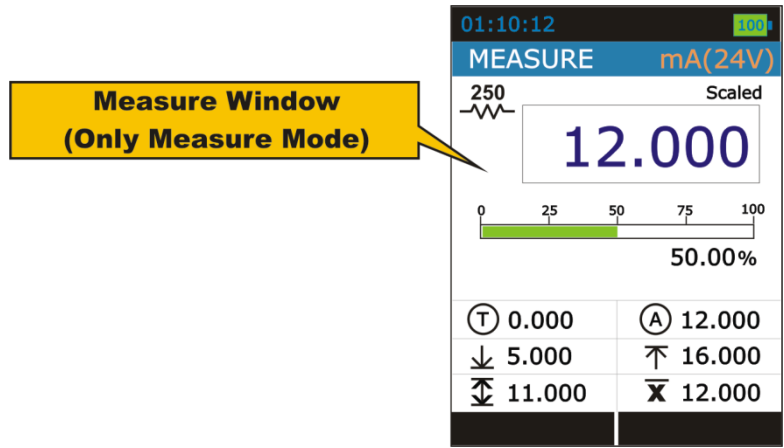







All possible elements are not included in the previous picture, but the important ones are discussed in the following chapters.

3.2.1 The Status Bar



The Status Bar at the top of the display is visible only in RUN Page. It is divided into four main sections.

1	<p>Time in HH:MM:SS Format</p> <p>Available in Two Format</p> <ol style="list-style-type: none"> 1. 24 Hour (default) 2. 12 Hour <p><i>This setting is available in Date/Time in Settings Menu</i></p>																		
2	<p>Error Code Indicator</p> <p>This Icon is visible if any On-Board Peripherals like RTC, ADC, DAC, etc not working Properly. Refer Section 5.1 on Page 49 for Troubleshooting these Errors.</p> <p>The List of Error Code available in this device is given below.</p> <table border="1" style="width: 100%; border-collapse: collapse;"> <thead> <tr> <th style="text-align: center;">Error Code</th> <th style="text-align: center;">Description</th> </tr> </thead> <tbody> <tr> <td style="text-align: center;">0</td> <td>Memory Corrupted or Device Unable to Read/Write it.</td> </tr> <tr> <td style="text-align: center;">1</td> <td>RTC Not working Properly</td> </tr> <tr> <td style="text-align: center;">2</td> <td>Device unable to Read battery Information.</td> </tr> <tr> <td style="text-align: center;">3</td> <td>Measure Mode Not Working</td> </tr> <tr> <td style="text-align: center;">4</td> <td>Device unable to get Source Feedback Reading.</td> </tr> <tr> <td style="text-align: center;">5</td> <td>Data Log Memory Corrupt</td> </tr> <tr> <td style="text-align: center;">6</td> <td>Source Mode Not Working</td> </tr> <tr> <td style="text-align: center;">9</td> <td>More than one Errors from above list is occurring.</td> </tr> </tbody> </table>	Error Code	Description	0	Memory Corrupted or Device Unable to Read/Write it.	1	RTC Not working Properly	2	Device unable to Read battery Information.	3	Measure Mode Not Working	4	Device unable to get Source Feedback Reading.	5	Data Log Memory Corrupt	6	Source Mode Not Working	9	More than one Errors from above list is occurring.
Error Code	Description																		
0	Memory Corrupted or Device Unable to Read/Write it.																		
1	RTC Not working Properly																		
2	Device unable to Read battery Information.																		
3	Measure Mode Not Working																		
4	Device unable to get Source Feedback Reading.																		
5	Data Log Memory Corrupt																		
6	Source Mode Not Working																		
9	More than one Errors from above list is occurring.																		
3	<p>USB Connection Status Icon</p> <p>Icon is visible if USB Charger Adaptor or USB Data Cable is connected to the Device. Icon is different for both indication & this stated below.</p> <table border="1" style="width: 100%; border-collapse: collapse;"> <tbody> <tr> <td style="text-align: center;"></td> <td>USB Data Cable is connected & Communication with PC is available.</td> </tr> <tr> <td style="text-align: center;"></td> <td>USB Charger Adaptor is connected. Battery starts Charging.</td> </tr> </tbody> </table>		USB Data Cable is connected & Communication with PC is available.		USB Charger Adaptor is connected. Battery starts Charging.														
	USB Data Cable is connected & Communication with PC is available.																		
	USB Charger Adaptor is connected. Battery starts Charging.																		
4	<p>Battery Charge Percentage Indicator.</p> <p>Always visible in Run page. Battery % is shown in the centre of the icon. And the icon background is filled with Green, Yellow & Red color if Battery % is $\geq 50\%$, ≥ 20 & <20 respectively.</p>																		
5	<p>Data Logging Enable Status Indicator.</p> <p>Icon is visible if Data Logging is enabled and also it will blink when a Datalog is stored to memory.</p>																		

3.2.2 The Function key Bar



The Function Key Bar at the bottom of the display is visible all the time. There are 2 Function Key Available. The meaning of the Function Keys varies depending on the situation. A Blank Function key text means that the function is disabled at the moment.





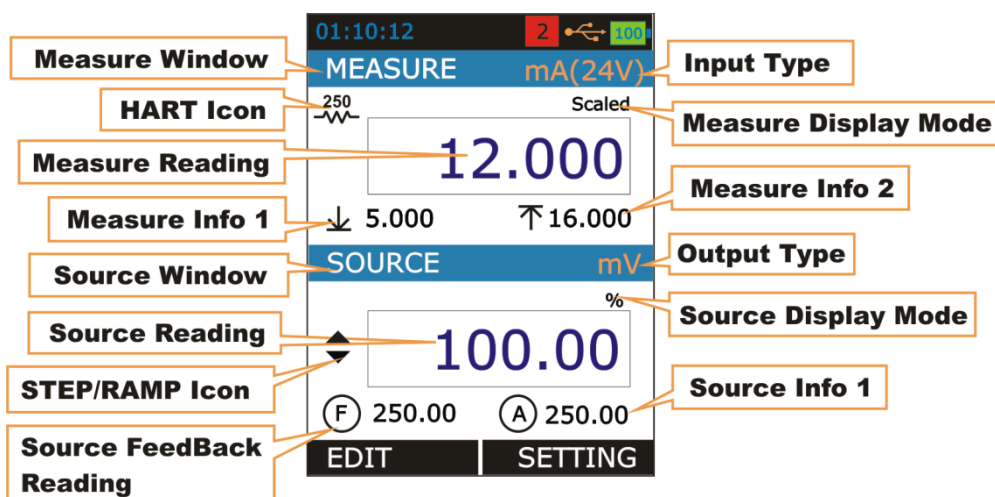















3.2.3 Display Mode

1. Measure + Source



Measure Window									
Input Type	The Input Type. <table border="1"> <tr> <td>mA</td> <td>mA Current Input</td> </tr> <tr> <td>mA(24V)</td> <td>mA Current (Read Power-24V) Input</td> </tr> <tr> <td>mV</td> <td>mV Voltage Input</td> </tr> <tr> <td>V</td> <td>V Voltage Input</td> </tr> </table>	mA	mA Current Input	mA(24V)	mA Current (Read Power-24V) Input	mV	mV Voltage Input	V	V Voltage Input
mA	mA Current Input								
mA(24V)	mA Current (Read Power-24V) Input								
mV	mV Voltage Input								
V	V Voltage Input								
Measure Display Mode	The Measure Reading Display Mode. <table border="1"> <tr> <td>Actual</td> <td>Displays the Raw Input Value without any scaling</td> </tr> <tr> <td>Percentage</td> <td>Displays the Percentage Value in (0.00% - 100.00%)</td> </tr> <tr> <td>Scaled</td> <td>Displays the Scaled Value</td> </tr> </table>	Actual	Displays the Raw Input Value without any scaling	Percentage	Displays the Percentage Value in (0.00% - 100.00%)	Scaled	Displays the Scaled Value		
Actual	Displays the Raw Input Value without any scaling								
Percentage	Displays the Percentage Value in (0.00% - 100.00%)								
Scaled	Displays the Scaled Value								
Measure Reading	The Reading as per the Measure Display Mode								
Measure Info 1	Shows the One of the available Addition Information. This can be selected by Additional Info. 1 List in <i>MENU → DISPLAY → MEASURE</i> page.								

Measure Info 2	Shows the One of the available Addition Information. This can be selected by Additional Info. 2 List in <i>MENU → DISPLAY → MEASURE</i> page. This will disable if Bargraph is selected as Additional Info1 in <i>MENU → DISPLAY → MEASURE</i> page.
HART Icon	HART Enable Status Icon. This icon will appear if HART is enabled from <i>MENU → SETTING → HART</i> page. (This icon is visible for mA(24V) Input Type only. For other Input Types this will invisible regardless of HART settings)

Source Window																	
Output Type	The Output Type. <table border="1" style="width: 100%;"> <tr> <td>mA</td> <td>mA Current Output</td> </tr> <tr> <td>mA(2W)</td> <td>mA Current (2-Wire Simulation) Output</td> </tr> <tr> <td>mV</td> <td>mV Voltage Output</td> </tr> <tr> <td>V</td> <td>V Voltage Output</td> </tr> </table>	mA	mA Current Output	mA(2W)	mA Current (2-Wire Simulation) Output	mV	mV Voltage Output	V	V Voltage Output								
mA	mA Current Output																
mA(2W)	mA Current (2-Wire Simulation) Output																
mV	mV Voltage Output																
V	V Voltage Output																
Source Display Mode	The Source Reading Display Mode. <table border="1" style="width: 100%;"> <tr> <td>Actual</td> <td>Displays the Raw Output Value without any scaling</td> </tr> <tr> <td>Percentage</td> <td>Displays the Percentage Value in (0.00% - 100.00%)</td> </tr> <tr> <td>Scaled</td> <td>Displays the Scaled Value</td> </tr> </table>	Actual	Displays the Raw Output Value without any scaling	Percentage	Displays the Percentage Value in (0.00% - 100.00%)	Scaled	Displays the Scaled Value										
Actual	Displays the Raw Output Value without any scaling																
Percentage	Displays the Percentage Value in (0.00% - 100.00%)																
Scaled	Displays the Scaled Value																
Source Reading	The Reading as per the Source Display Mode																
Source Feedback Reading	The Feedback ADC Reading in Output Unit. This will disable if Bargraph is selected as Additional Info1 in <i>MENU → DISPLAY → SOURCE</i> page.																
Source Info1	Shows the One of the available Addition Information. This can be selected by Additional Info. 1 List in <i>MENU → DISPLAY → SOURCE</i> page.																
STEP/RAMP Icon	Shows the Icon indicating STEP/RAMP mode. <table border="1" style="width: 100%;"> <tr> <td style="text-align: center;"></td> <td>Manual Step</td> <td style="text-align: center;"></td> <td>Rising Ramp</td> </tr> <tr> <td style="text-align: center;"></td> <td>Step UP</td> <td style="text-align: center;"></td> <td>Falling Ramp</td> </tr> <tr> <td style="text-align: center;"></td> <td>Step DOWN</td> <td style="text-align: center;"></td> <td>Ramp Hold @ 0%</td> </tr> <tr> <td></td> <td></td> <td style="text-align: center;"></td> <td>Ramp Hold @ 100%</td> </tr> </table>		Manual Step		Rising Ramp		Step UP		Falling Ramp		Step DOWN		Ramp Hold @ 0%				Ramp Hold @ 100%
	Manual Step		Rising Ramp														
	Step UP		Falling Ramp														
	Step DOWN		Ramp Hold @ 0%														
			Ramp Hold @ 100%														

2. Measure Only

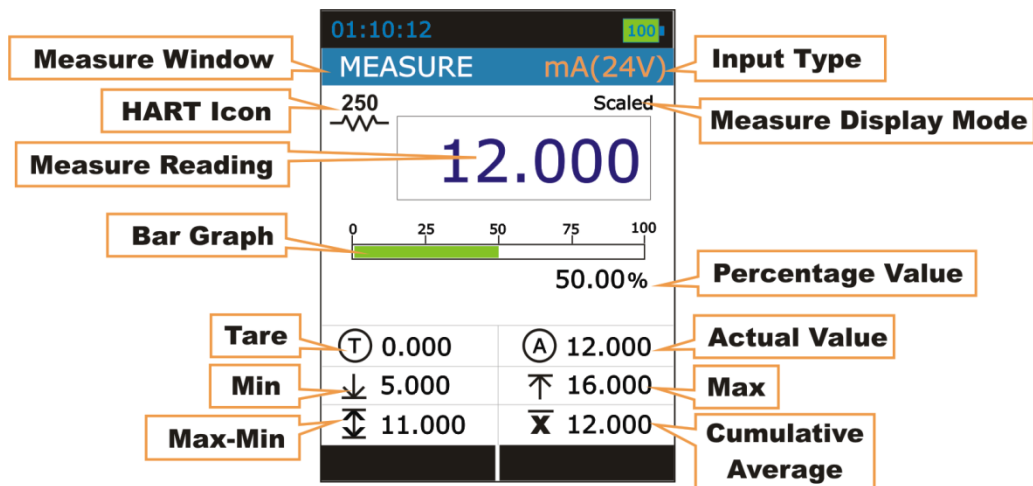

Measure Window	
Input Type Measure Display Mode Measure Reading HART Icon	Refer Measure Window Table of Measure + Source Display Mode on Page 19.
Bar Graph	Horizontal Bar graph according to Input Percentage Value (0.00% - 100.00%).
Percentage Value	The Percentage Value in (0.00% - 100.00%) according to Input Value.
Tare	The Tare Value Set from <i>MENU</i> → <i>DISPLAY</i> → <i>MEASURE-Tare</i> page
Actual Value	The Raw Input Value without any scaling This will appear only if Main Display in <i>MENU</i> → <i>DISPLAY</i> → <i>MEASURE</i> is set to PERCENTAGE/SCALED .
Min	Displays the minimum value found after a measurement was started or minimum was reset.
Max	Displays the maximum value found after a measurement was started or maximum was reset.
Max-Min	Displays the Maximum-Minimum value found after a measurement was started or Maximum-Minimum was reset.
Cumulative Average	Displays the Cumulative Average value found after a measurement was started or Cumulative Average was reset.

3. Source Only

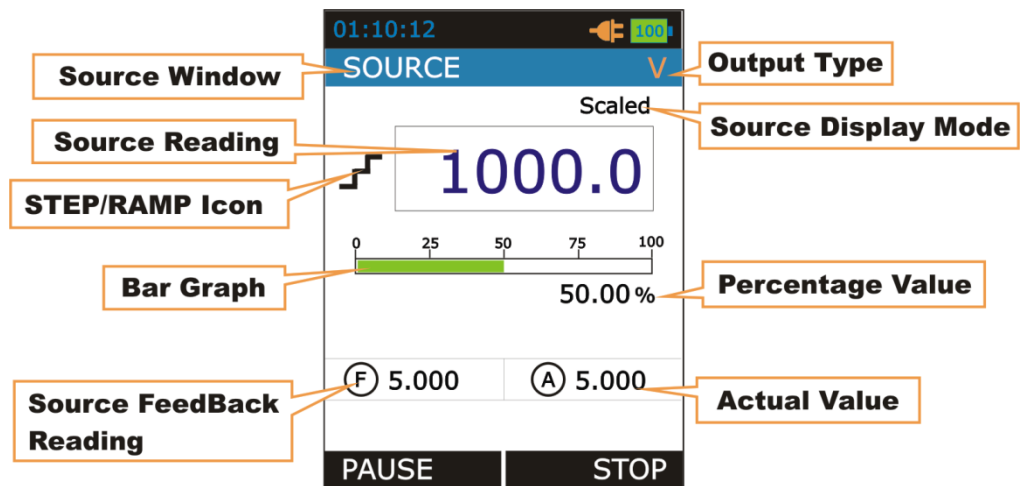

Source Window	
Output Type Source Display Mode Source Reading Source Feedback Reading STEP/RAMP Icon	Refer Measure Window Table of Measure + Source Display Mode on Page 19.
Bar Graph	Horizontal Bar graph according to Output Percentage Value (0.00% - 100.00%).
Percentage Value	The Percentage Value in (0.00% - 100.00%) according to Output Value.
Actual Value	The Raw Output Value without any scaling This will appear only if Main Display in <i>MENU</i> → <i>DISPLAY</i> → <i>SOURCE</i> is set to PERCENTAGE/SCALED .

4. Switch Test + Source

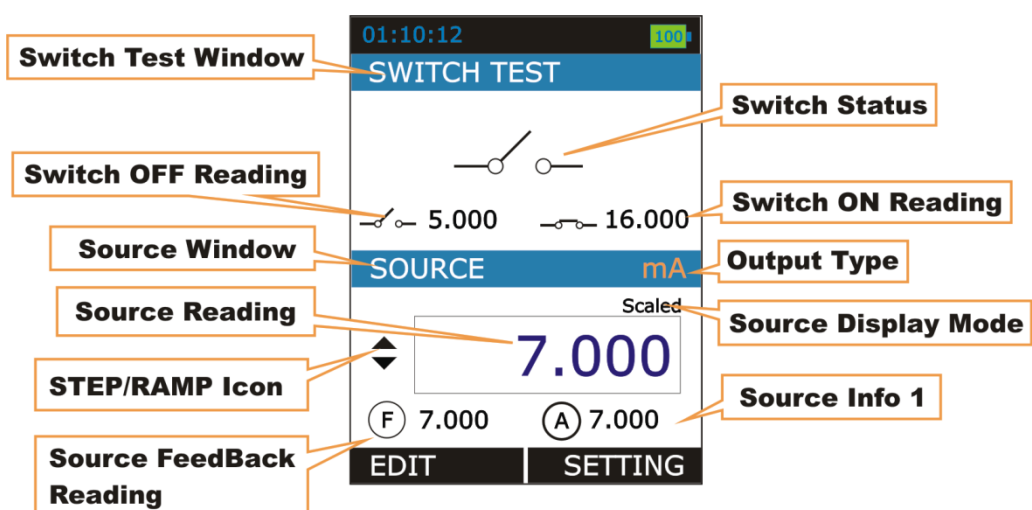

Switch Test Window

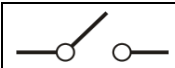
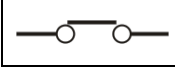
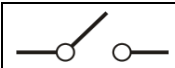
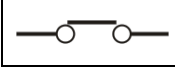
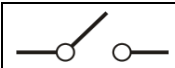
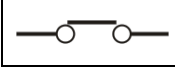
Switch Status	Switch Status Icon <table border="1"> <tr> <td></td> <td>Switch OPEN (OFF)</td> </tr> <tr> <td></td> <td>Switch CLOSE (ON)</td> </tr> </table>		Switch OPEN (OFF)		Switch CLOSE (ON)
	Switch OPEN (OFF)				
	Switch CLOSE (ON)				
Switch OPEN Reading	Displays the Source Reading value after the switch OPEN was detected.				
Switch CLOSE Reading	Displays the Source Reading value after the switch CLOSE was detected.				

Source Window	
Output Type Source Display Mode Source Reading Source FeedBack Reading Source Info 1 STEP/RAMP Icon	Refer Measure Window Table of Measure + Source Display Mode on Page 19.

3.2.4 Display Operations

There are mainly four types of widgets available in the Device Menu Style.

- i. ListBox
- ii. EditText
- iii. CheckBox
- iv. RadioButtonBox

The below section will show how to change the value of different widgets.

- **ListBox**

ListBox are used when there is a limited amount of preset values. You have to select one of the available options. The list of available options is displayed in the Centre part.

A ListBox List opens when you press the **F1** key. Use **UP/DOWN** key to scroll through the available options. Select one of the options with the **ENTER** key.

Example: How to change of Input Type (I/P Type) from mA to mV.

This Option is available in *MENU* → *MEASURE* Page.

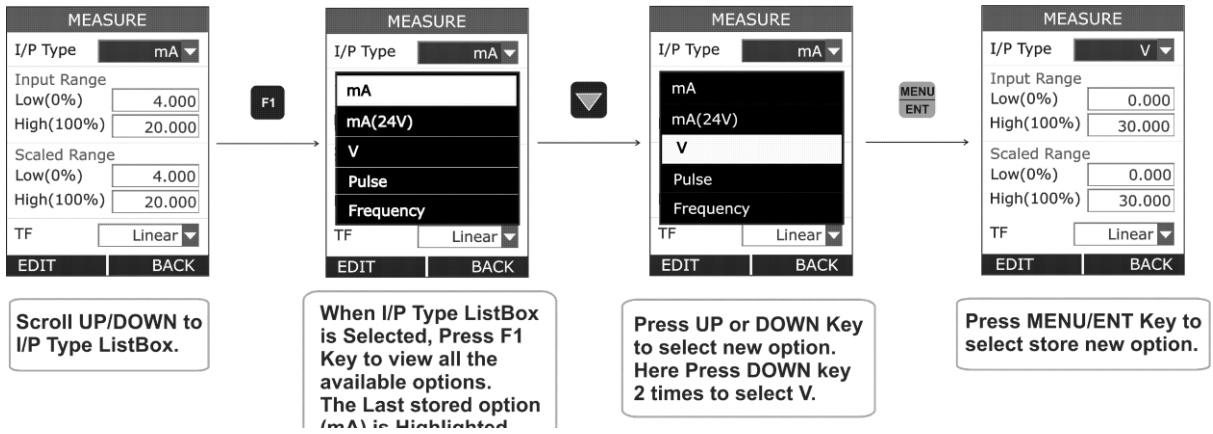

• **EditBox**

EditBox is used where a large range of value can be possible for a parameter.

To edit the value of an EditBox press **F1** key. After that EditBox enters into the Edit mode where **F1** & **F2** keys are works as shifter. User can shift to desired digit and using **UP** or **DOWN** key digit value can be incremented or decremented. The modified value can be saved using **MENU/ENT** key.

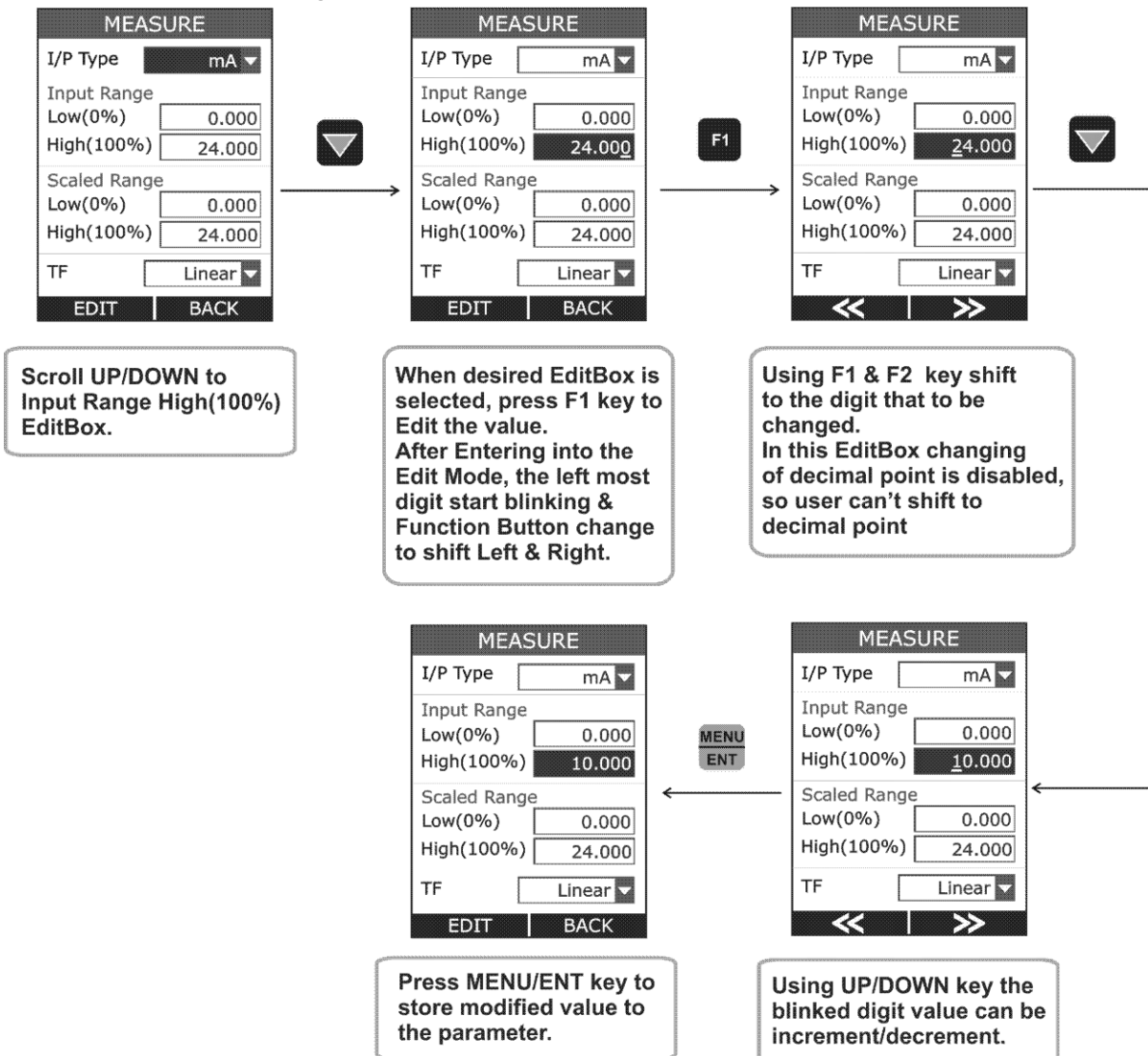

The above figure shows the example how to change Input High(100%) Range from 20.000 to 10.000 mA.

There are mainly 2 types of EditBox in this device. In most of the EditBox changing of decimal point & changing of sign is not allowed. But there are few EditBox, where these are allowed. These types of EditBox are Scaled Low(0%) & High(100%) Range of measure & source, Alarm Low & High value and Editing of Source Value in RUN Page.

The below figure shown the example how to change decimal point of the Input Scaled High(100%) Range.

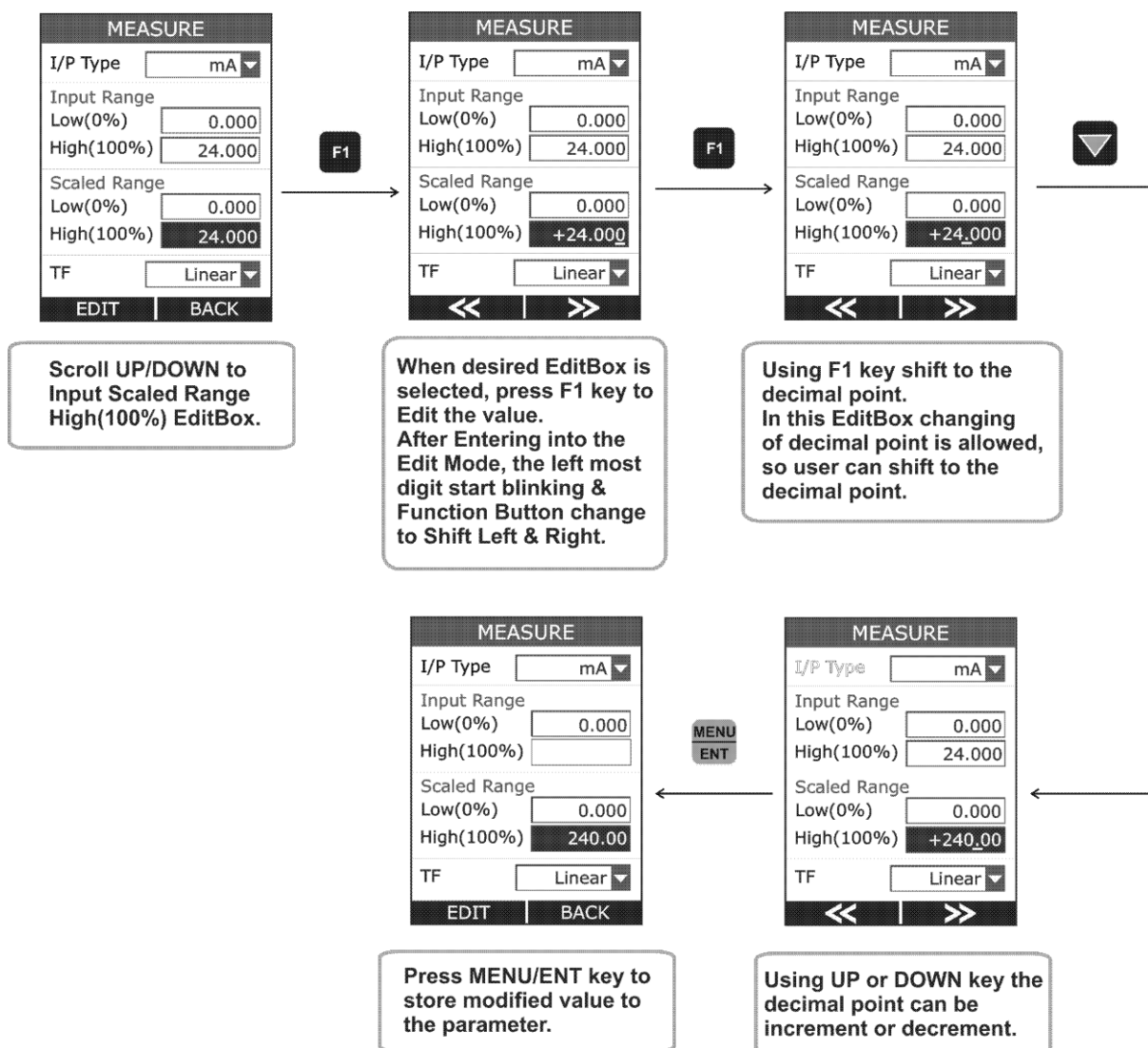

To change the sign of the value, shift to the sign digit and pressing UP or DOWN key will toggle the sign.

- **CheckBox**

CheckBox is used where Binary Value (1/0, True/False) is available for any parameter.

To change the CheckBox status press **F1** key. This will enter into the edit mode. In this mode status can be toggled by pressing **F1** key. Press **MENU/ENT** key to store new status.

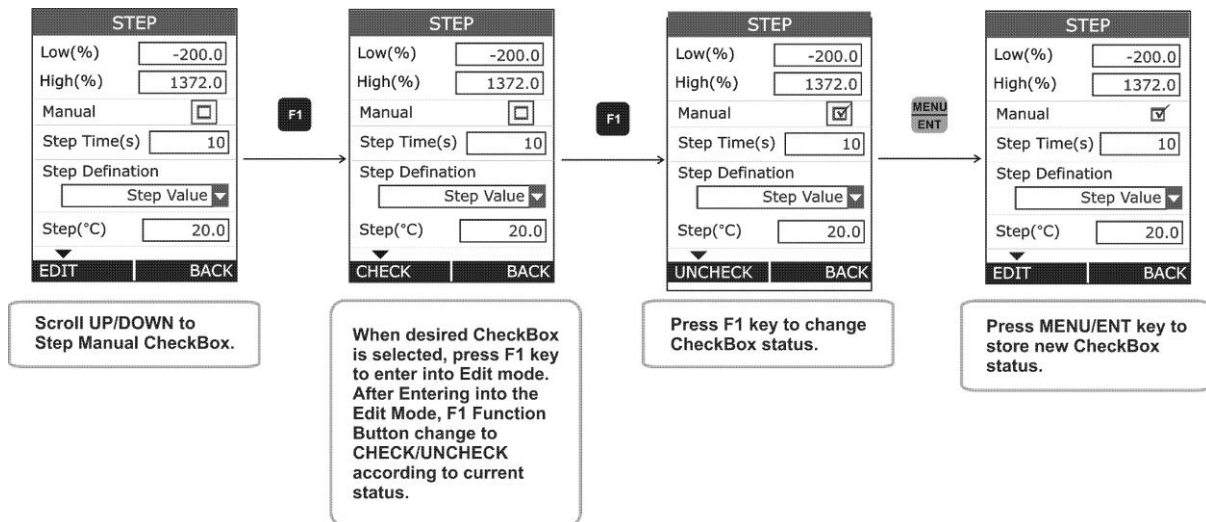

- **RadioButtonBox**

RadioButtonBox is used where very few values can be possible and all the available values need to be visible.

In this device, two types of RadioButtonBox are available. One with 1 value can be selectable & the other where 1 or 2 values can be selectable at a time.

In RadioButtonBox the other option can be selected by pressing MENU/ENT key on that option. When pressing this key the new option will be selected and the other option will be disabled.

Below an example is given, How to change Source Type from STEP to Ramp.

TC SETUP	
TC Mode	
MEASURE	<input type="checkbox"/>
SOURCE	<input checked="" type="checkbox"/>
TC Select	
Unit	Celsius ▾
Source Mode	
STEP	<input type="checkbox"/>
RAMP	<input type="checkbox"/>
EDIT	BACK

MENU
ENT



TC SETUP	
TC Mode	
MEASURE	<input type="checkbox"/>
SOURCE	<input checked="" type="checkbox"/>
TC Select	
Unit	Celsius ▾
Source Mode	
STEP	<input type="checkbox"/>
RAMP	<input checked="" type="checkbox"/>
EDIT	BACK

Scroll UP/DOWN to
Desired RadioButton
option.

Press MENU/ENT key
to select the option.
Now the new option is
selected and other
option will be disabled.

4. Menu Layout

4.1 MENU page

There are mainly six Menus in this device.

To enter into the MENU page press **MENU/ENT** key & press **F2** key to come out from Menu page.

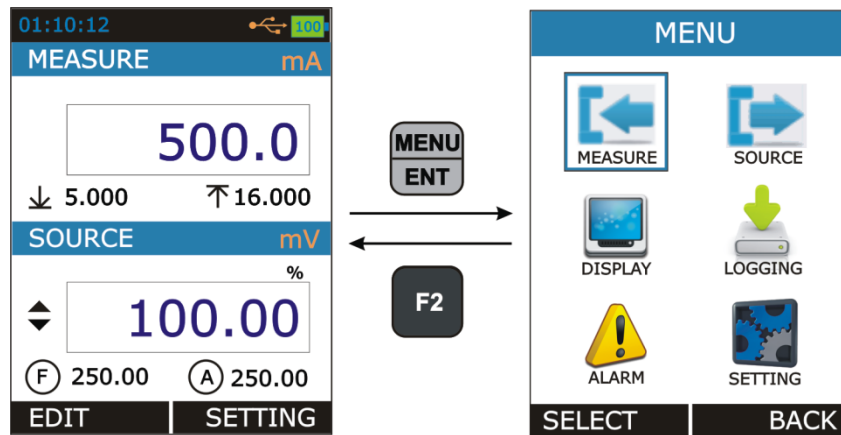

MEASURE	Contains Parameters related to Measure Mode like Input Type, Range etc.
SOURCE	Contains Parameters related to Source Mode like Output Type, Range, Source Type etc.
DISPLAY	Contains Parameters related to different display mode for RUN page
LOGGING	Contains Parameters related to Data Logging. (This)
ALARM	Contains Parameters related to Alarm & Alarm Set-Points.
SETTINGS	Contains Parameters related to General Settings of the device like display, Date/Time, Calibration, Reset, etc.

4.2 MEASURE Page

This Page is appears in *RUN* → *MENU* → *MEASURE*.

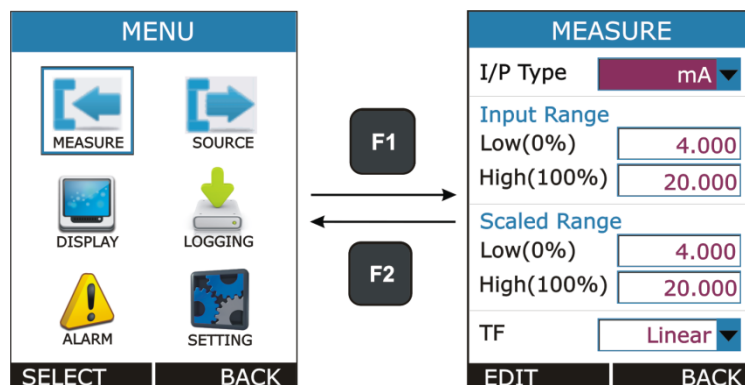

This page contains parameters related to Measure like Input Type, Input Range, Scaling and Transfer Function. The Description of the Parameters appear on this page is given below.

Parameter Name	Description / Options
I/P Type (Input Type)	Measure Input Type <u>Available Options:</u> mA : 0.000 to 24.000 mA DC mA(24V) : 0.000 to 24.000 mA DC mV : 0.00 to 250.00 mV DC V : 0.000 to 30.000 V DC
Input Range Low (0%)	Low Range for Measure Input. <u>Range:</u> Default Input Low to Input Range High(100%) This parameter is enabled, if Main Display in <i>MENU → DISPLAY → MEASURE</i> is set to Percentage or Scaled .
Input Range High (100%)	High Range for Measure Input. <u>Range:</u> Input Range Low(0%) to Default Input High This parameter is enabled, if Main Display in <i>MENU → DISPLAY → MEASURE</i> is set to Percentage or Scaled .
Scaled Input Range Low(0%)	Scaling Low Range for Measure Input. <u>Range:</u> -99999 to Scaled Input Range High(100%) Decimal Point for this EditBox can be changeable. This parameter is enabled, if Main Display in <i>MENU → DISPLAY → MEASURE</i> is set to Scaled .
Scaled Input Range High(100%)	Scaling High Range for Measure Input. <u>Range:</u> Scaled Input Range Low(0%) to 99999 Decimal Point for this EditBox can be changeable. This parameter is enabled, if Main Display in <i>MENU → DISPLAY → MEASURE</i> is set to Scaled .
TF (Transfer Function)	Transfer Function for Scaling <u>Available Options:</u> Linear $x^2 (x^2)$ $x^{(1/2)} (\sqrt{x})$ This parameter is enabled, if Main Display in <i>MENU → DISPLAY → MEASURE</i> is set to Scaled .

4.2 SOURCE Page

This Page is appears in *RUN* → *MENU* → *SOURCE*.

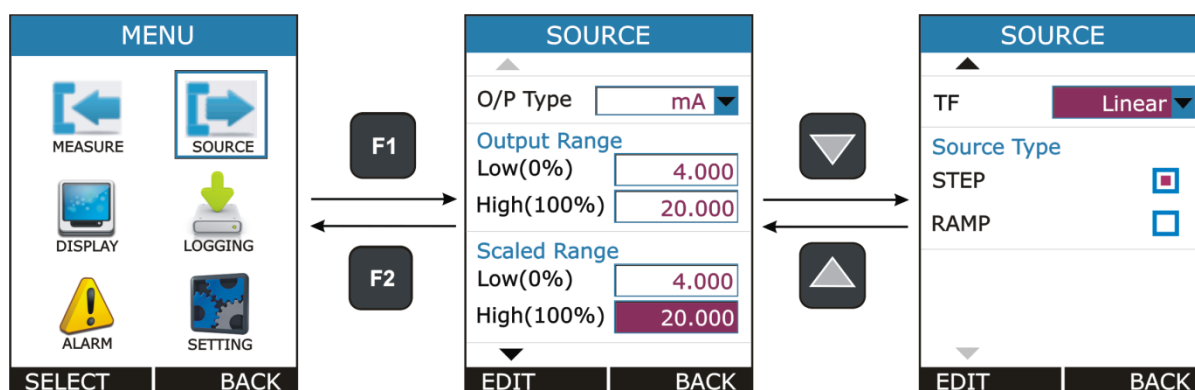

This page contains parameters related to Measure like Output Type, Output Range, Scaling, Transfer Function Step and Ramp. The Description of the Parameters appear on this page is given below.

Parameter Name	Description / Options
O/P Type (Output Type)	Source Output Type <u>Available Options:</u> mA : 0.000 to 24.000 mA DC mA(2W) : 0.000 to 24.000 mA DC mV : 0.00 to 250.00 mV DC V : 0.000 to 12.000 V DC
Output Range Low (0%)	Low Range for Source Output. <u>Range:</u> Default Output Low to Output Range High(100%) This parameter is enabled, if Main Display in <i>MENU</i> → <i>DISPLAY</i> → <i>SOURCE</i> is set to Percentage or Scaled .
Output Range High (100%)	High Range for Source Output. <u>Range:</u> Output Range Low(0%) to Default Output High This parameter is enabled, if Main Display in <i>MENU</i> → <i>DISPLAY</i> → <i>SOURCE</i> is set to Percentage or Scaled .
Scaled Output Range Low(0%)	Scaling Low Range for Source Output. <u>Range:</u> -99999 to Scaled Output Range High(100%) Decimal Point for this EditBox can be changeable. This parameter is enabled, if Main Display in <i>MENU</i> → <i>DISPLAY</i> → <i>SOURCE</i> is set to Scaled .
Scaled Output Range High(100%)	Scaling High Range for Source Output <u>Range:</u> Scaled Output Range Low(0%) to 99999 Decimal Point for this EditBox can be changeable. This parameter is enabled, if Main Display in <i>MENU</i> → <i>DISPLAY</i> → <i>SOURCE</i> is set to Scaled .

TF (Transfer Function)	Transfer Function for Scaling <u>Available Options:</u> Linear x^2 (x^2) $x^{1/2}$ (\sqrt{x}) This parameter is enabled, if Main Display in <i>MENU</i> → <i>DISPLAY</i> → <i>SOURCE</i> is set to Scaled .
Source Type	Source Output Format <u>Available Options:</u> STEP RAMP At a time one can be selectable. Press F1 key on the one of the option for more settings.

4.2.1 STEP Page

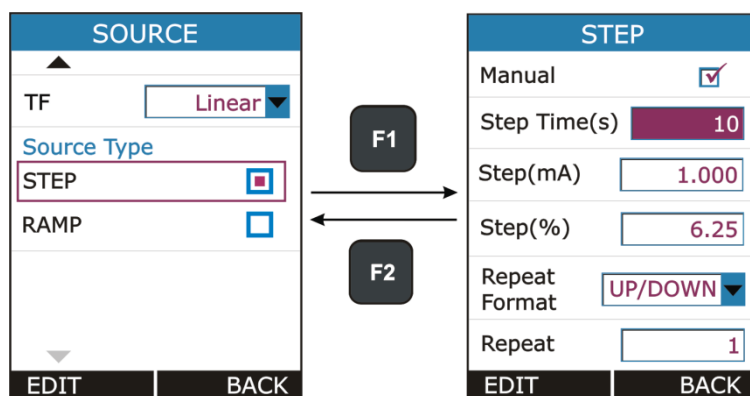

Parameter Name	Description / Options
Manual (Output Type)	Step Manual Mode Selection CheckBox. Ticking this checkbox will enable Step Manual Mode. And Un-ticking will enable Auto Step Mode.
Step Time (s)	Enter the time for a single step in seconds, <u>Range:</u> 1 to 9999 This parameter is enabled only for Auto Step Mode (Manual CheckBox is Un-Checked)
Step(unit) Step Size in unit	Step Size in unit, where unit is changed according to current Output Type and Source Display Mode. Only Specify one Step(unit) or Step(%), the other will automatically changed according to the changed parameter. <u>Range:</u> In accordance with Output Range & Source Display Mode. This parameter is disabled, if Main Display in <i>MENU</i> → <i>DISPLAY</i> → <i>SOURCE</i> is set to Percentage .
Step(%)	Step Size in Percentage.

Step Size in Percentage	Only Specify one Step(unit) or Step(%), the other will automatically changed according to the changed parameter. <u>Range:</u> 0.00 to 100.00
Repeat Format	How the stepping should be done. <u>Available Options:</u> UP DOWN UP/DOWN DOWN/UP This parameter is enabled only for Auto Step Mode (Manual CheckBox is Un-Checked)
Repeat Repeat Counts	Defines how many times the steps are repeated <u>Range:</u> 1 to 9999 This parameter is enabled only for Auto Step Mode (Manual CheckBox is Un-Checked)

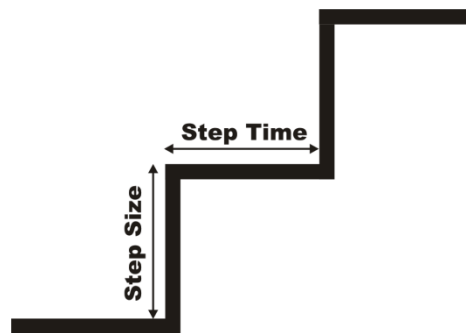

- **Manual Stepping**

To Enable Manual Stepping, select Source Type as STEP & Check the Manual CheckBox.



If this mode is enabled,  icon will appear in Source Display Window in RUN Page.

Pressing UP or DOWN key in RUN Page will Increment or Decrement Source Value by Step Size specified in STEP Page.

In RUN Page, Source Value can directly change by Pressing **F1** key (EDIT) and modifying value like in EditBox. & STEP Setting can be accessed directly by **F2** key (SETTING).

- **Auto Stepping**

To Enable Auto Stepping, select Source Type as STEP & Un-Check the Manual CheckBox.

If this mode is enabled,  (Step UP) or  (Step Down) icon will appear in Source Display Window in RUN Page and F1 & F2 Button change to **START & SETTING** respectively.

Automated Step can be started by Pressing **F1** key (START). After that F1 & F2 key will change to **PAUSE & STOP** respectively. So by pressing F1 & F2 key running STEP can be PAUSE or STOP at any time in RUN Page.

STEP Setting can be accessed directly by **F2** key (SETTING).

NOTE: While STEP is running STEP settings can't be accessible and Source Page Parameter settings can't be change. Stop STEP before changing any settings.

4.2.2 RAMP Page

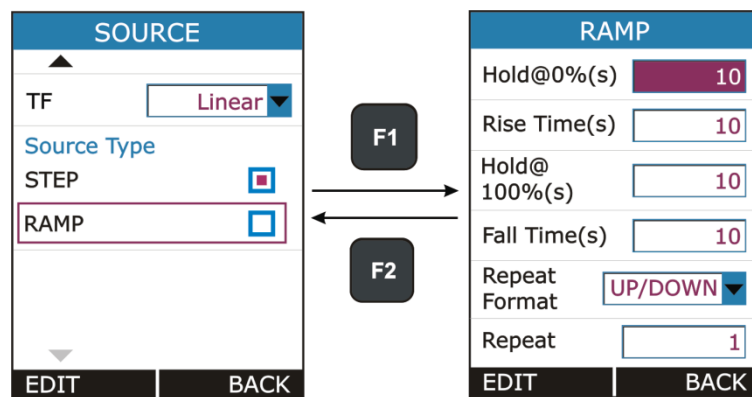

Parameter Name	Description / Options
Hold@0%(s)	Time to wait at Low(0%) level in second. This parameter is use for Repeat Format UP/DOWN or DOWN/UP . <u>Range:</u> 0 to 9999
Rise Time (s)	Time to Increase from Low to High Level. <u>Range:</u> 1 to 9999
Hold@100%(s)	Time to wait at High(100%) level in second. This parameter is use for Repeat Format UP/DOWN or DOWN/UP . <u>Range:</u> 0 to 9999
Fall Time (s)	Time to decrease from High to Low Level. <u>Range:</u> 1 to 9999
Repeat Format	How the Ramp should be done.

	<u>Available Options:</u> UP DOWN UP/DOWN DOWN/UP
Repeat Repeat Counts	Defines how many times the steps are repeated <u>Range:</u> 1 to 9999

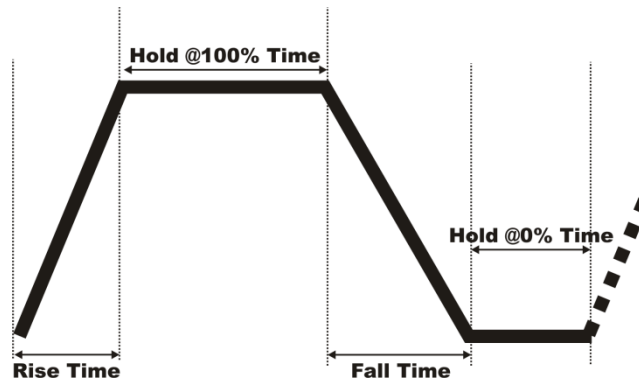

- **Starting the RAMP**

To Enable Ramp, select Source Type as RAMP.

If this mode is enabled, \nearrow (Rising Ramp) or \searrow (Falling Ramp) or $\overline{\wedge}$ (Ramp Hold @ 100%) or $\overline{\vee}$ (Ramp Hold @ 0%) icon will appear in Source Display Window according to current RAMP mode in RUN Page and F1 & F2 Button change to **START** & **SETTING** respectively.

RAMP can be started by Pressing **F1** key (START). After that F1 & F2 key will change to **PAUSE** & **STOP** respectively. So by pressing F1 & F2 key running RAMP can be PAUSE or STOP at any time in RUN Page.

NOTE: While RAMP is running RAMP settings can't be accessible and Source Page Parameter settings can't be change. Stop RAMP before changing any settings.

4.3 DISPLAY Page

This Page is appears in *RUN* → *MENU* → *DISPLAY*.

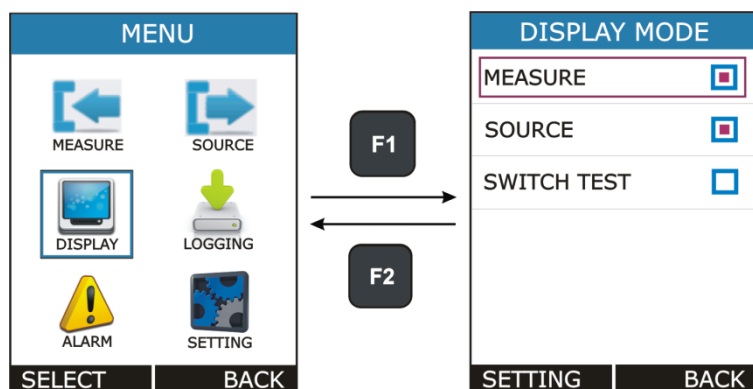

There is mainly Four RUN Display Mode possible in this device. And this mode can be selected from the above Page. What information to be shown in each RUN Display Mode can be defined by this page.

In this page there is one RadioButtonBox. At a time one or two option can be selected. The possible combinations are given below.

1	Measure Only
2	Source Only
3	Measure + Source
4	Switch Test + Source

4.3.1 Measure Display Settings

This Page is appears in *RUN* → *MENU* → *DISPLAY* → *MEASURE*.

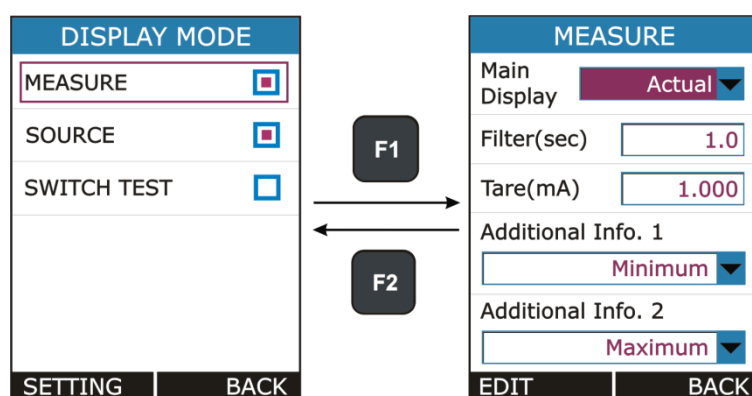

Parameter Name	Description / Options			
Main Display	Select which Reading to be display as a Main Reading (Reading Displays in Box in RUN Page).			
	Available Options:			
	<table border="1"> <tr> <td>Actual</td> <td>Display the Actual Input Value</td> </tr> <tr> <td>Percentage</td> <td>Display the Percentage Value of the Input.</td> </tr> </table>	Actual	Display the Actual Input Value	Percentage
Actual	Display the Actual Input Value			
Percentage	Display the Percentage Value of the Input.			

	<table border="1"> <tr> <td></td> <td>The Value depends on Input Range. These settings are available from <i>MENU</i> → <i>MEASURE</i>.</td> </tr> <tr> <td>Scaled</td> <td>Display the Scaled Value of the Input. The Scale Value depends on Input Range, Input Scaled Range & Transfer Function. These settings are available from <i>MENU</i> → <i>MEASURE</i>.</td> </tr> </table>		The Value depends on Input Range. These settings are available from <i>MENU</i> → <i>MEASURE</i> .	Scaled	Display the Scaled Value of the Input. The Scale Value depends on Input Range, Input Scaled Range & Transfer Function. These settings are available from <i>MENU</i> → <i>MEASURE</i> .																							
	The Value depends on Input Range. These settings are available from <i>MENU</i> → <i>MEASURE</i> .																											
Scaled	Display the Scaled Value of the Input. The Scale Value depends on Input Range, Input Scaled Range & Transfer Function. These settings are available from <i>MENU</i> → <i>MEASURE</i> .																											
Filter(sec)	<p>1st Order IIR Low Pass Filter for Input Reading. Filter is useful when a measurement signal contains unwanted noise.</p> <p><u>Range:</u> 0.0 to 60.0 sec</p>																											
Tare(unit)	<p>The Tare value is subtracted from the reading of the measured value. Here unit is changed according to current Input Type and Measure Display Mode.</p> <p><u>Range:</u> In accordance with Input Range & Measure Display Mode.</p> <p>Note: Beware of the problems that may result in not seeing the true measurement value.</p>																											
Additional Info.1	<p>Choose which information to be shown in Bottom Left side of the Measure Window on RUN Page.</p> <p><u>Available Options:</u></p> <table border="1"> <thead> <tr> <th>Options</th> <th>Icon</th> <th>Description</th> </tr> </thead> <tbody> <tr> <td>Reset</td> <td>-</td> <td>Reset the Minimum, Maximum, Max – Min, Cumulative Avg. Value</td> </tr> <tr> <td>None</td> <td>-</td> <td>No info is visible.</td> </tr> <tr> <td>Minimum</td> <td>↓</td> <td>Displays the minimum value found after a measurement was started or minimum was reset</td> </tr> <tr> <td>Maximum</td> <td>↑</td> <td>Displays the maximum value found after a measurement was started or maximum was reset</td> </tr> <tr> <td>Max – Min</td> <td>↕</td> <td>Displays the (maximum – minimum) value found after a measurement was started or (maximum – minimum) was reset</td> </tr> <tr> <td>Avg. of 2</td> <td>\bar{x}</td> <td>Displays the average value of present value and previous value.</td> </tr> <tr> <td>Bargraph</td> <td>-</td> <td>Shows the Horizontal bar Graph in 0% to 100% scale. The value in Bar Graph depends on the Display Mode and Measurement settings</td> </tr> <tr> <td>Actual Value</td> <td>Ⓐ</td> <td>Shows the Actual Input Value. This option is not appear if Main Display is Actual.</td> </tr> </tbody> </table> <p>If Measure is not selected as Display mode this parameter will be disabled. And for Only Measure Display Mode Only Reset Option is available.</p>	Options	Icon	Description	Reset	-	Reset the Minimum, Maximum, Max – Min, Cumulative Avg. Value	None	-	No info is visible.	Minimum	↓	Displays the minimum value found after a measurement was started or minimum was reset	Maximum	↑	Displays the maximum value found after a measurement was started or maximum was reset	Max – Min	↕	Displays the (maximum – minimum) value found after a measurement was started or (maximum – minimum) was reset	Avg. of 2	\bar{x}	Displays the average value of present value and previous value.	Bargraph	-	Shows the Horizontal bar Graph in 0% to 100% scale. The value in Bar Graph depends on the Display Mode and Measurement settings	Actual Value	Ⓐ	Shows the Actual Input Value. This option is not appear if Main Display is Actual .
Options	Icon	Description																										
Reset	-	Reset the Minimum, Maximum, Max – Min, Cumulative Avg. Value																										
None	-	No info is visible.																										
Minimum	↓	Displays the minimum value found after a measurement was started or minimum was reset																										
Maximum	↑	Displays the maximum value found after a measurement was started or maximum was reset																										
Max – Min	↕	Displays the (maximum – minimum) value found after a measurement was started or (maximum – minimum) was reset																										
Avg. of 2	\bar{x}	Displays the average value of present value and previous value.																										
Bargraph	-	Shows the Horizontal bar Graph in 0% to 100% scale. The value in Bar Graph depends on the Display Mode and Measurement settings																										
Actual Value	Ⓐ	Shows the Actual Input Value. This option is not appear if Main Display is Actual .																										

Additional Info.2

Choose which information to be shown in Bottom Right side of the Measure Window on RUN Page.

Options	Icon	Description
Reset	-	Reset the Minimum, Maximum, Max – Min, Cumulative Avg. Value
None	-	No info is visible.
Minimum	↓	Displays the minimum value found after a measurement was started or minimum was reset
Maximum	↑	Displays the maximum value found after a measurement was started or maximum was reset
Max – Min	↕	Displays the (maximum – minimum) value found after a measurement was started or (maximum – minimum) was reset
Avg. of 2	\bar{x}	Displays the average value of present value and previous value.
Actual Value	Ⓐ	Shows the Actual Input Value. This option is not appear if Main Display is Actual .

If Measure is not selected as Display mode this parameter will be disabled.

4.3.2 Source Display Settings

This Page is appears in *RUN* → *MENU* → *DISPLAY* → *SOURCE*.

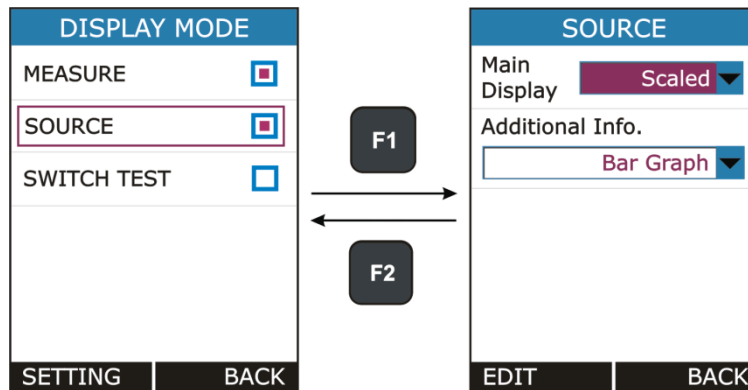

Parameter Name	Description / Options						
Main Display	<p>Select which Reading to be display as a Main Reading (Reading Displays in Box in RUN Page).</p> <p>Available Options:</p> <table border="1"> <tbody> <tr> <td>Actual</td> <td>Display the Actual Output Value</td> </tr> <tr> <td>Percentage</td> <td>Display the Percentage Value of the Output. The Value depends on Output Range. These settings are available from <i>MENU</i> → <i>SOURCE</i>.</td> </tr> <tr> <td>Scaled</td> <td>Display the Scaled Value of the Output. The Scale Value depends on Output Range, Output Scaled Range & Transfer Function. These settings are available from <i>MENU</i> → <i>SOURCE</i>.</td> </tr> </tbody> </table>	Actual	Display the Actual Output Value	Percentage	Display the Percentage Value of the Output. The Value depends on Output Range. These settings are available from <i>MENU</i> → <i>SOURCE</i> .	Scaled	Display the Scaled Value of the Output. The Scale Value depends on Output Range, Output Scaled Range & Transfer Function. These settings are available from <i>MENU</i> → <i>SOURCE</i> .
Actual	Display the Actual Output Value						
Percentage	Display the Percentage Value of the Output. The Value depends on Output Range. These settings are available from <i>MENU</i> → <i>SOURCE</i> .						
Scaled	Display the Scaled Value of the Output. The Scale Value depends on Output Range, Output Scaled Range & Transfer Function. These settings are available from <i>MENU</i> → <i>SOURCE</i> .						
Additional Info.1	Choose which information to be shown in Bottom Right side of the Source Window on RUN Page.						

<u>Available Options:</u>		
Options	Icon	Description
None	-	No info is visible.
Bargraph	-	Shows the Horizontal bar Graph in 0% to 100% scale. The value in Bar Graph depends on the Display Mode and Source settings
Actual Value		Shows the Actual Output Value. This option is not appear if Main Display is Actual .
This Parameter is enabled only for Measure + Source or Switch test + Source Display Mode.		

4.3.3 Switch Test Settings

This Page is appears in *RUN* → *MENU* → *DISPLAY* → *SWITCH TEST*.

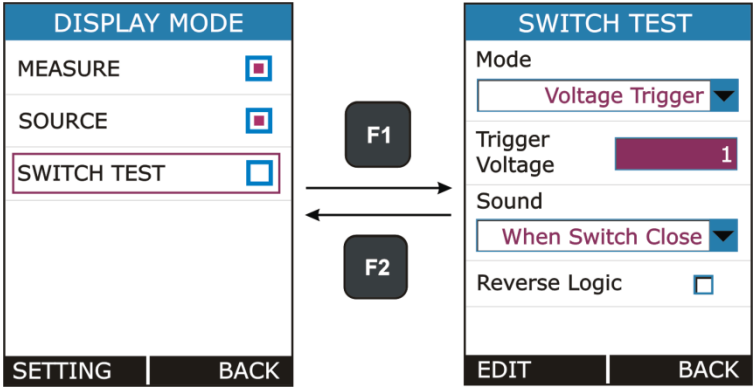

Parameter Name	Description / Options				
Mode	Switch Test Operation Mode <u>Available Options:</u> <table border="1" data-bbox="488 1424 1393 1659"> <tr> <td>2V(24Vdc,30mA)</td> <td>Switch Close when External Switch (Potential Free Contacts) short & Switch Open is External Switch open.</td> </tr> <tr> <td>Voltage Trigger</td> <td>Switch Close when Input Voltage > Trigger Voltage Switch Open when Input Voltage < Trigger Voltage</td> </tr> </table> All the MEASURE Page parameters are disabled if Switch Test Display Mode is selected.	2V(24Vdc,30mA)	Switch Close when External Switch (Potential Free Contacts) short & Switch Open is External Switch open.	Voltage Trigger	Switch Close when Input Voltage > Trigger Voltage Switch Open when Input Voltage < Trigger Voltage
2V(24Vdc,30mA)	Switch Close when External Switch (Potential Free Contacts) short & Switch Open is External Switch open.				
Voltage Trigger	Switch Close when Input Voltage > Trigger Voltage Switch Open when Input Voltage < Trigger Voltage				
Trigger Voltage	Trigger Voltage value for Voltage Trigger Switch Test Mode. <u>Range:</u> 0 to 30 V Enable only for Switch Test Mode as Voltage Trigger .				
Sound	Sound Setting for Switch Test Mode <u>Available Options:</u> Off When Switch Close				



	When Switch Open
Reverse Logic	Switch Test Switch Logic Reverse Selection. Switch Open-Close Logic Reverse if this CheckBox is Checked.

4.4 DATA LOGGING Page

This section gives examples of how to log Readings with time and date over a set time period or on a key press. Logged data is stored in a user defined file in internal memory.

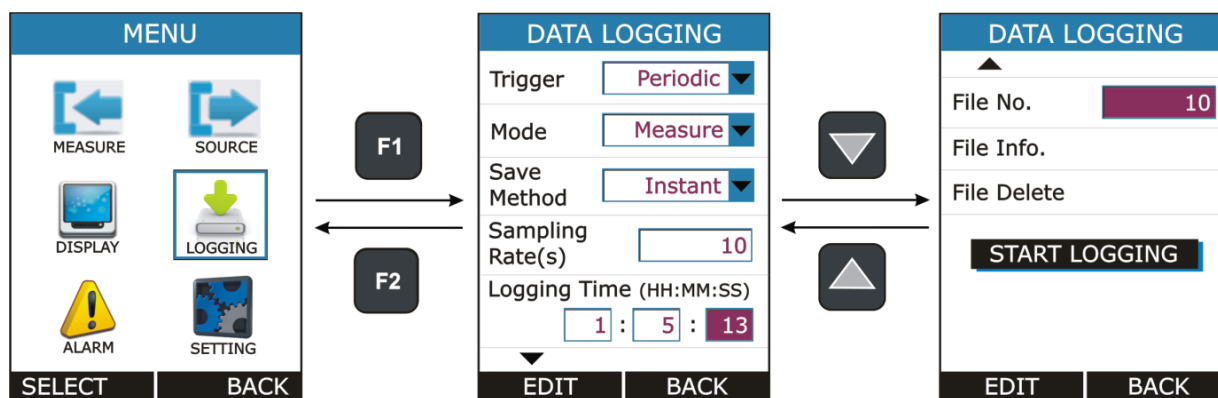
This Page is appears in *RUN* → *MENU* → *LOGGING*.



Parameter Name	Description / Options								
Trigger	Data Logging Trigger Mode Selection. <u>Available Options:</u> <table border="1"> <tr> <td>Key Press</td> <td>Log Data on pressing  from RUN key Page.</td> </tr> <tr> <td>Periodic</td> <td>Log Data periodically at every Sampling Rate for total time specified by Logging Time.</td> </tr> </table>	Key Press	Log Data on pressing  from RUN key Page.	Periodic	Log Data periodically at every Sampling Rate for total time specified by Logging Time.				
Key Press	Log Data on pressing  from RUN key Page.								
Periodic	Log Data periodically at every Sampling Rate for total time specified by Logging Time.								
Mode	Data Mode Selection for Logging <u>Available Options:</u> <table border="1"> <tr> <td>Measure</td> <td>Log only Measure Readings.</td> </tr> <tr> <td>Source</td> <td>Log only Source Readings.</td> </tr> <tr> <td>Both</td> <td>Log Measure and Source both Readings.</td> </tr> <tr> <td>Switch</td> <td>Log Switch Status & Source Readings.</td> </tr> </table> <p>This parameter is enabled only for Periodic Trigger.</p>	Measure	Log only Measure Readings.	Source	Log only Source Readings.	Both	Log Measure and Source both Readings.	Switch	Log Switch Status & Source Readings.
Measure	Log only Measure Readings.								
Source	Log only Source Readings.								
Both	Log Measure and Source both Readings.								
Switch	Log Switch Status & Source Readings.								
Save Method	Reading Type selection for Logging <u>Available Options:</u> Instant Min Max Average All This parameter is enabled only for Periodic Trigger.								
Sampling Rate(s)	Sampling Rate for Periodic Data Logging in seconds.								

	<u>Range:</u> 1 to 9999 This parameter is enabled only for Periodic Trigger.
Logging Time (HH:MM:SS)	Total Logging Time in HH:MM:SS Format for Periodic Logging. This parameter is enabled only for Periodic Trigger.
File No.	File Number. <u>Range:</u> 1 to 25 This parameter is enabled only for Periodic Trigger.
File Info.	Shows the information of stored files. This information contains Logging Start Time & Date and No of Samples stored in the file.
File Delete	Delete stored file.
START LOGGING	Press F1 key while selecting this button to start the Logging.

NOTES:

- Maximum No of Reading that can be stored in,

Logging Mode	Max. Reading
Periodic	150000
Key Press	572

- In Periodic mode, changing of any Measure or Source parameter is not allowed. So While Periodic Logging is Running, User can't enter into *MEASURE*, *SOURCE* and *DISPLAY* menu. But in Key Press Logging mode, there is no restriction.
- In Periodic Mode, if error message like “*Not Sufficient Memory*” comes while starting the Logging. Try to Reduce Logging Time or Increase Sampling Period or try deleting some existing files.
- In Key Press Mode, If No of Samples reach its maximum limit that is 484, the next sample will start from the first overwriting the memory.
- While Logging is running, entering into the *LOGGING* menu shows below page.

for Periodic Mode

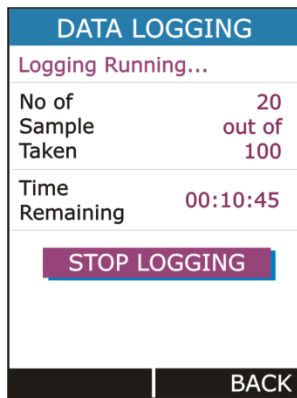

for Key Press Mode

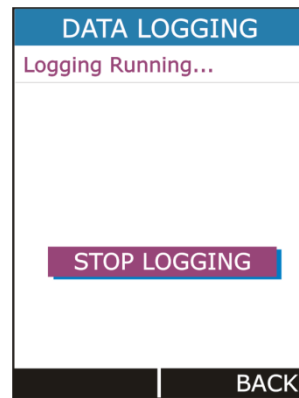

For Periodic Mode, this page contains information of Number of Samples Taken and Time Remaining for Logging in HH:MM:SS.

- Both Periodic and Key Press logging can be stop manually by pressing F1 key on STOP LOGGING Button. For Periodic Mode, Logging will automatically stopped when defined log time ends and a message “ LOGGING DONE ” pop ups.

Transferring the Results to a Personal Computer:

A 32-bit Windows® software called **mCAL+.exe** is shipped together with LC-12 if you bought the Data Logging option. Start this software just as any other Windows® software.

All communication between the PC and LC-12 is initiated from **mCAL+.exe**.

More information of the software in mL12Im101_00.pdf document available in software CD.

4.5 ALARM Page

This Page is appears in *RUN → MENU → ALARM*.

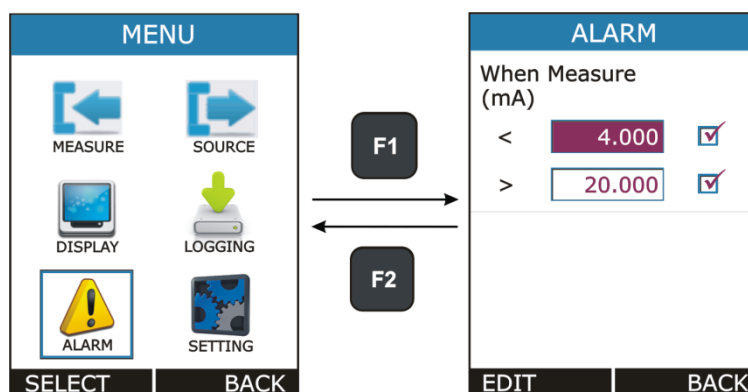

Individual alarm limit values may also be enabled/disabled using the check box preceding the alarm limit value.

When an alarm limit is exceeded, LC-12 emits an audible alarm and the Main Reading is shown with RED Color.

To stop alarm uncheck the appropriate alarm checkbox.

Parameter Name	Description / Options
<	Alarm Low Limit Value <u>Range:</u> In accordance with Input Range & Measure Display Mode. And also it can't be greater than Alarm High Limit when High Alarm is enabled.
>	Alarm High Limit Value <u>Range:</u> In accordance with Input Range & Measure Display Mode. And also it can't be less than Alarm Low Limit when Low Alarm is enabled.

4.6 SETTING Page

This Page is appears in *RUN* → *MENU* → *SETTING*.

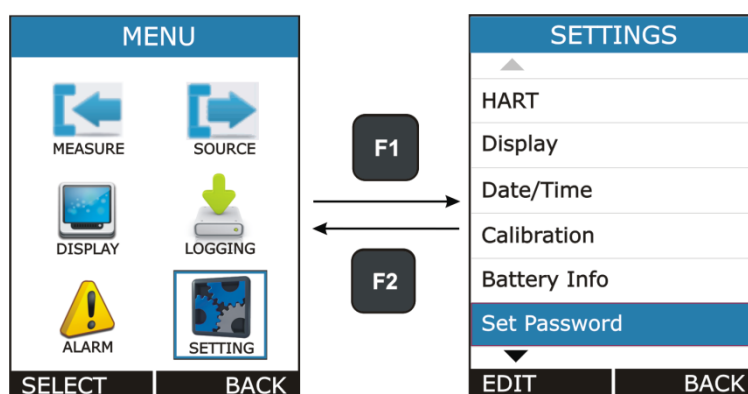

All the available Settings Options are given below.

- i. HART
- ii. Display
- iii. Date/Time
- iv. Calibration
- v. Battery Info.
- vi. Set Password
- vii. Factory Reset
- viii. About Calibrator

Press F1 key to Enter into the settings of any option.

Description of all settings given below.

HART	
HART (250 ohms)	
NO	<input checked="" type="checkbox"/>
YES	<input type="checkbox"/>
<div style="display: flex; justify-content: space-between;"> EDIT BACK </div>	

4.6.1 HART Settings

Select YES to add a Series resistor (250Ω) into the mA circuit. You can then use this instrument together with a HART® communicator to set up and calibrate HART® devices. This option is applicable for mA(24V) Read Power Input Type Only.

DISPLAY	
Display Intensity(%)	<input type="text" value="100"/>
Display Off Time(s) (0=Infinite)	<input type="text" value="10"/>
<div style="display: flex; justify-content: space-between;"> EDIT BACK </div>	

4.6.2 Display Settings

Display Intensity	Display Brightness Settings. <u>Range:</u> 1 to 100
Display Off Time	Standby Time in second after which display will turn Off. To turn the display off press any key. <u>Range:</u> 0 to 9999 sec Setting 0 will disable this feature. That means display will never turn off automatically.

DATE/TIME	
Date	<input type="text" value="1"/> / <input type="text" value="5"/> / <input type="text" value="13"/> <small>DD MM YY</small>
Date Format	<input type="text" value="DD/MM/YY"/> ▼
Time	<input type="text" value="1"/> : <input type="text" value="5"/> : <input type="text" value="13"/> <small>HH MM SS</small>
	<input type="text" value="AM"/> ▼
Time Format	<input type="text" value="12 Hour"/> ▼
<div style="display: flex; justify-content: space-between;"> EDIT BACK </div>	

4.6.3 Date/Time Settings

To set the Time + Date of the device.

There are 2 Date Format supported in this device **DD/MM/YY** & **MM/DD/YY**. This is useful only in Data Logging, to decide in which format Date to be stored.

There are 2 Time format supported in this device **24 Hour** & **12 Hour**. This is to select in which format the time should be displayed on Run page & time to be stored in Data Logging.

AM/PM selection is enabled only for 12 Hour Time Format.

4.6.4 Calibration

The instrument is factory calibrated for the specified range, but due to long term drift of components, re-calibration may be necessary in some cases. For calibrating the instrument a reliable source is required. This source should be at least ten times accurate compared to the range of the instrument.

Note: Masibus can provide a calibration service that is traceable to international standards.

We recommend that you return the instrument to the manufacturer or an approved service agent for calibration. If you use an alternative calibration facility, make sure that it uses these standards.

The unit can be calibrated without opening it and without trim pots. To enter in calibration mode follow the steps below.

First press the MENU/ENT key in RUN mode to enter in Menu page. In Menu page select the Settings option and press F1 key to enter into the Setting mode. In setting mode select the Calibration option and press F1 key to enter into the calibration mode.

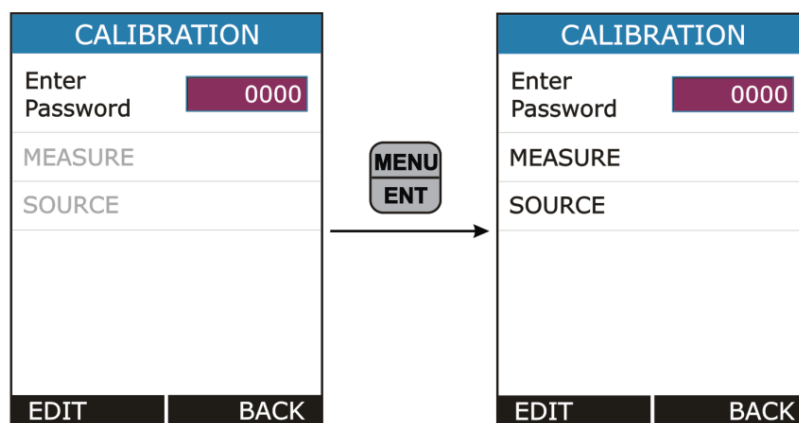

**Press F1 Key to Enter Into the Password Edit Mode.
Press UP or DOWN key to change to the Right Password value.**

Press Enter key to verify the Password. If the password is correct Measure & Source calibration options will be enabled.

To calibrate the instrument first enter the correct password. If the entered password is correct Measure & Source Calibration option will be enabled.

- **Procedure for calibration of Measure Mode**

First select the Input Type which to be calibrated.

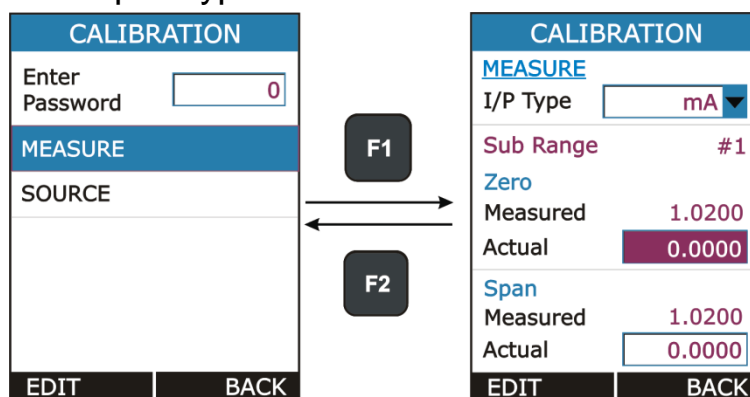

For Better Calibration Input Range is divided into two sub ranges. So For each input type, Calibration of both sub ranges need to done. The Sub Ranges of each input type is given in the below table.

Input Type	Sub Ranges	Recommended Calibration Points
mA (0.000 to 24.000 mA)	1. 0.000 to 12.000 mA	ZERO: 1.000 mA SPAN: 11.000 mA
	2. 12.000 to 24.000 mA	ZERO: 13.000 mA SPAN: 23.000 mA
mA(24V) (0.000 to 24.000 mA)	1. 0.000 to 12.000 mA	ZERO: 1.000 mA SPAN: 11.000 mA
	2. 12.000 to 24.000 mA	ZERO: 13.000 mA SPAN: 23.000 mA
mV (0.00 to 250.00m V)	1. 0.00 to 125.00 mV	ZERO: 15.00 mV SPAN: 110.00 mV
	2. 125.00 mV to 250.00 mV	ZERO: 140.00 mV SPAN: 235.00 mV
V (0.000 to 30.000 V)	1. 0.000 to 15.000 V	ZERO: 1.000 V SPAN: 14.000 V
	2. 15.000 to 30.000 V	ZERO: 16.000 V SPAN: 29.000 V

Note: It is not compulsory to calibrate at recommended points. User can calibrate at any points within specified Sub Range. The Sub Range is shown on the screen. But make sure to calibrate Zero & Span in the same sub range.

Example: - Calibrating mA Input

To calibrate **ZERO for Sub Range #1,**

- Apply mA Input value near to Recommended Zero Value for Sub Range 1 (for mA sub range 1 it is 1.000mA) from reliable source device.

- For example, If apply 1.000mA from the external source. **Measured** value shows the value that has been measured by the LC-12. If this value is 1.0200 enter 1.0000 value in **ZERO Actual Value** Edit Box & Press **MENU/ENT** key to calibrate the ZERO.

Similarly, for **SPAN for Sub Range #1** calibration,

- Apply mA Input value near to Recommended Span Value for Sub Range 1 (for mA sub range 1 it is 11.000mA) from reliable source device.
- For example, If apply 11.000mA from the external source. If the **Measured** value shows 10.9950 enter 11.0000 value in **SPAN Actual Value** Edit Box & Press **MENU/ENT** key to calibrate the SPAN.
- Follow the same procedure to calibrate for the Sub Range 2.
- The same procedure is applicable for other Input Type.
- To calibrate input use other source in series or parallel to device according to the input type which is ten times accurate compared to the range of the instrument.

Note: Calibration of mA Input will also calibrate mA(24V) input. No need to separately calibrate mA(24V) Input.

- **Procedure for calibration of Source Mode**

To enter into the Source Calibration, Select the **SOURCE** option and press **F1** key to see Source calibration page. To calibrate the Source mode **ZERO** and **SPAN** both has to be calibrated. First calibrate Zero and then Span.

First select the Output Type which to be calibrated.

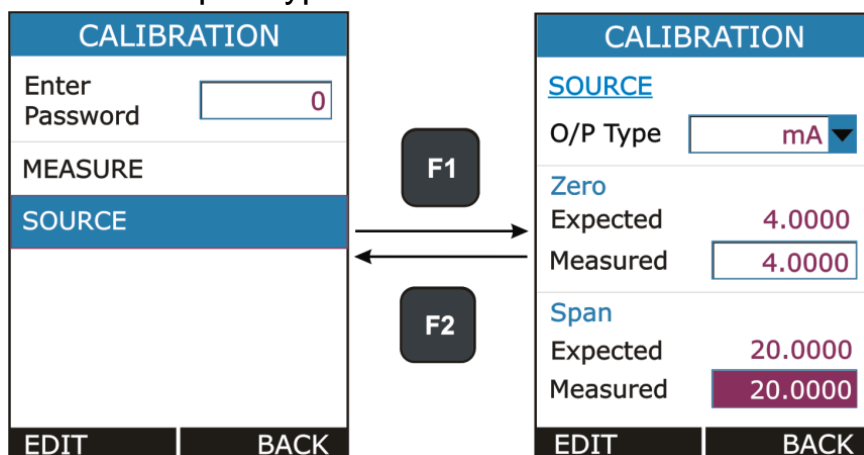

Example: - Calibrating mA Output

To calibrate **ZERO**,

- Select **ZERO Measured** Edit Box, when this Edit Box is selected LC-12 will source value that is seen in **ZERO Expected** Value (here LC-12 will source 4.000mA).
- Now Measure the source value in Reliable Measure Unit. For Example the external measure unit is measuring 3.9980mA. Then enter 3.9980 value in **ZERO Measured** Edit Box & Press **MENU/ENT** key to calibrate the ZERO.

To calibrate **SPAN**,

- Select **SPAN Measured** Edit Box, when this Edit Box is selected LC-12 will source value that is seen in **SPAN Expected** Value (here LC-12 will source 20.000mA).
 - Now Measure the source value in Reliable Measure Unit. For Example the external measure unit is measuring 20.0100mA. Then enter 20.0100 value in **SPAN Measured** Edit Box & Press **MENU/ENT** key to calibrate the SPAN.
 - Follow the same procedure to calibrate the other output types.
- Expected Values of Zero and Span for source calibration are as per below table.

Output Type	Expected Zero Value	Expected Span Value
mA	4.0000	20.0000
mV	25.000	240.000
V	1.0000	11.0000

Note: Calibration of mA Output will also calibrate mA(2W) Output. No need to separately calibrate mA(2W) Output.

Note:

- Usually, LC-12 calibrates using the above steps in one/two time only. But if the Input / Output are very out from the desired value repeat the Calibration steps until the device calibrated properly.
-

BATTERY INFO.	
Level(%)	90
Voltage(mV)	4100
Current(mA)	500
Status	Charging
Time to Full(min)	30
Time to Empty(min)	-
BACK	

4.6.5 Battery Info.

This page shows the basic battery Information.

- Battery Level (Percentage)
- Battery Voltage (in mV)
- Current (in mA)
- Battery Status
- Time to Full (in min)
- Time to Empty (in min)

SET PASSWORD	
Current Password	<input type="password" value="0"/>
New Password	<input type="password" value="0"/>
EDIT BACK	

4.6.6 Set Password

Change Device Password.

This password has to be entered before Calibrating & Resetting Configuration Parameters.

To change password Enter Current Password. If the entered password is correct then New Password EditText will be enabled. Then enter the New Password and press **MENU/ENT** key to store it.

FACTORY RESET	
Enter Password	<input type="password" value="0"/>
Configuration RESET	
NO	<input checked="" type="checkbox"/>
YES	<input type="checkbox"/>
EDIT BACK	

4.6.7 Factory Reset

To Reset LC-12 Parameters to its Default Value.

To Reset Enter Current Password. If the entered password is correct then New Password EditText will be enabled. Then enter the New Password and press **MENU/ENT** key to store it.

4.6.8 About Calibrator

This Page illustrates the Connection diagrams for valid connections to this device.

5. Maintenance & Troubleshooting

5.1 Common Problems

Problem	Possible Causes
Device Not Starting Up	<ul style="list-style-type: none">• Battery Discharged• Battery Connection Loose
Reading Fluctuation/ Reading OPEN	<ul style="list-style-type: none">• Wrong / Loose Connections
Error Code on status bar	<ul style="list-style-type: none">• One of the peripheral not working properly. (Solution: Restart the Device if still error code showing contact factory)
Calibration Out	<ul style="list-style-type: none">• Distortion in due to external noise connection (Solution: Check connection. If still out contact factory or Recalibrate Device in authorized cal-lab.)
Battery Not Charging	<ul style="list-style-type: none">• Battery Connection Loose• Battery Dead

5.2 Replacing the Battery

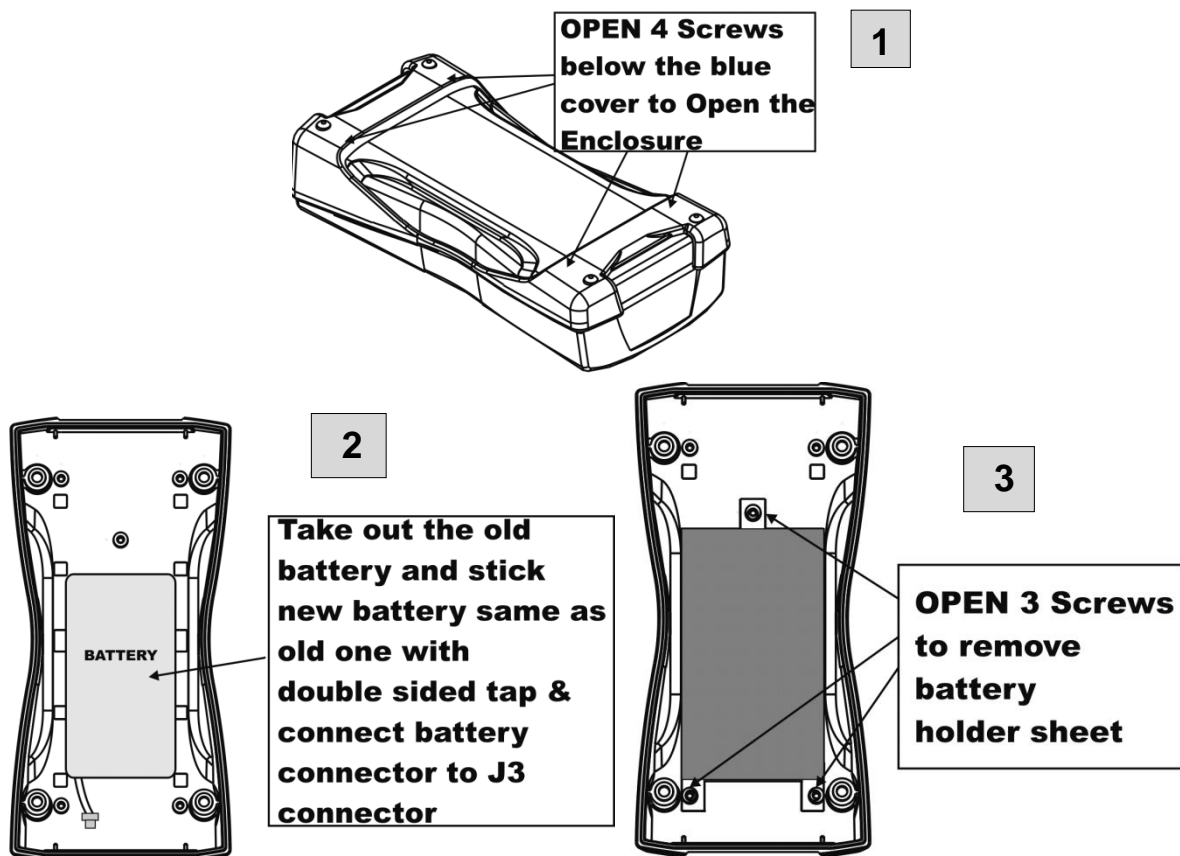

6. General Specifications

6.1 General Specifications

Parameter	LC 12 Specification	
Display	Color Graphical 42.72 mm x 60.26 mm, 240x320 pixels, Backlight LCD	
Weight	282 g	
Dimensions	161.7 mm x 82.1 mm x 39.5 mm	
Keyboard	6 Membrane Keys	
Battery Type	Rechargeable Li-ion battery pack, 2300mAh 3.7V	
Charging Time	<5 hours	
Charger supply	100-240 VAC, 50/60 Hz; Output 5V DC@1A	
Battery operation	>18 hours for mA, mV, V measurement with 5% backlight on, >8 hours for mA generation with 5% backlight on (24V DC@12mA)	
Battery Status Indication	Battery symbol displayed with % power remaining	
Operating temperature	0 ⁰ to 55 ⁰ C	
Operating temperature when charging batteries	0 to 45 ⁰ C	
Storage temperature	-20 ⁰ to 60 ⁰ C	
Relative Humidity	30% to 90% non-condensing	
Warm-up time	15 Minutes	
Max. input voltage	30 V DC	
Temperature Coefficient	30 ppm	
Input Impedance	V,mV	> 1MΩ
	mA	= 10Ω
Output Impedance	V, mV	> 10kΩ
	mA	< 750Ω
Response time	Input	<100ms
	Output	<100ms
Display update rate	10 / second	
Housing Material	ABS Plastic	
Electrical Terminals	Four 2 mm safety sockets	

6.2 Measurement Parameters and Accuracy

Parameter	Range	Resolution	Accuracy
mV	0-250.00 mV	0.01 mV	$\pm 0.02\%$ of reading ± 2 count
V	0-30.00 VDC	0.001 V	$\pm 0.02\%$ of reading ± 2 count
mA	0-24.00 mA	0.001 mA	$\pm 0.02\%$ of reading ± 2 count

6.3 Source Accuracy

Parameter	Range	Resolution	Accuracy
mV	0-250.00 mV	0.01 mV	$\pm 0.02\%$ of reading ± 2 count
V	0-12.00 VDC	0.001 V	$\pm 0.02\%$ of reading ± 2 count
mA	0-24.00 mA	0.001 mA	$\pm 0.02\%$ of reading ± 2 count

6.4 Testing Features

Feature	Value
Loop power output	24V DC, $\pm 10\%$ (24mA maximum)
Output impedance in HART compatible mode	$250\Omega \pm 20\%$
Switch Test	<ul style="list-style-type: none"> • Potential free contacts Trigger level : 24V, 24mA (2V) • Voltage level detection Trigger level : 0 to 30V in 1V steps Input impedance : $>1M\Omega$

6.5 Enclosure Dimensions

