

masibus

User's Manual

SINGLE LOOP PID CONTROLLER With AUTO TUNE

LC5296-AT
LC5248E-AT
LC5296V-AT



Masibus Automation & Instrumentation Pvt. Ltd.

B/30, GIDC Electronics Estate,
Sector-25, Gandhinagar-382044, Gujarat, India

☎ +91 79 23287275-77 📠 +91 79 23287281

Email: support@masibus.com

Web: www.masibus.com

Contents

1. INTRODUCTION	4
Foreword	4
Notice	4
Trademarks	4
Checking the Contents of the Package	4
List of Accessories	4
Safety Precautions	4
2. SPECIFICATIONS	6
2.1 Inputs	6
2.2 Display& Keys	6
2.3 Output Types	7
2.4 Communication Details	8
2.5 Power Supply	8
2.6 Environmental Conditions	9
3. PHYSICAL SPECIFICATIONS & MOUNTING DETAILS	9
3.1 LC5296-AT	9
3.3 LC5248E-AT	9
3.4 LC5296V-AT	10
4. TERMINAL CONNECTIONS	11
4.1 LC5296-AT	11
4.3 LC5248E-AT	12
4.4 LC5296V-AT	12
4.4 How to connect wires	13
5. FRONT PANEL DETAILS	14
5.1 Front Panel Description of LC5296-AT	14
5.3 Front Panel Description of LC5248E-AT/LC5296V-AT	15
6. MENU LAYOUT	17
6.1 Menu Layout for LC5296-AT	17
6.2 Menu Layout for LC5248E-AT/LC5296V-AT	19
6.3 RUN Time Indication/Function	21
6.4 Set Point Setting	21
6.5 AUTO TUNE MODE	21
6.6 CONFIGURATION MODE	22
6.7 CALIBRATIONMODE	26

- 7. CONTROL FUNCTION28**
 - 7.1 ON/OFF Control..... 28
 - 7.2 PID Control 29
 - 7.3 Ramp and Soak Function..... 31
 - 7.4 Motor Positon Control without slide wire feedback: 32

- 8. ALARM OUTPUT 33**
 - 8.1 ALARM TYPES 33

- 9. CALIBRATION PROCEDURE36**
 - 9.1 Procedure for CAL-zero and CAL-span..... 36
 - 9.2 Procedure for RET-zero and RET-span..... 36

- 10. COMMUNICATION PROTOCOL-MODBUS RTU.....37**
 - 10.1 Introduction..... 37
 - 10.2 Parameter Address Details..... 37
 - 10.3 Exceptional Response 39

- 11. APPENDIX40**
 - 11.1 Troubleshooting 40
 - 11.2 ON-OFF LOGIC..... 41
 - 11.3 Retransmission Output Table for OPEN /OVER /UNDER Condition 41
 - 11.4 Linear Output Table for OPEN/OVER/ UNDER Condition 41
 - 11.5 Jumper Settings for Addon Card Selection & RetransmissionOutput Type..... 42
 - 11.6 Load connection 44

1. INTRODUCTION

Foreword

Thank you for purchasing LCseriesDigital PID Controller with Auto Tuning.
LC5296-AT/ LC5248E-AT/ LC5296V-AT: (PID with Auto Tuning + ON-OFF Controller)

This manual describes the basic functions and operation methods. Please read through this user's manual carefully before using the product.

Notice

The contents of this manual are subject to change without notice as a result of continuous improvements to the instrument's performance and functions. Every effort has been made to ensure accuracy in the preparation of this manual. Should any errors or omissions come to your attention, however, please inform MASIBUS Sales office or sales representative. Under no circumstances may the contents of this manual, in part or in whole, be transcribed or copied without our permission.

Trademarks

Our product names or brand names mentioned in this manual are the trademarks or registered trademarks of Masibus Automation and Instrumentation (P) Ltd. (herein after referred to as **MASIBUS**).

Adobe, Acrobat, and Postscript are either registered trademarks or trademarks of Adobe Systems Incorporated. All other product names mentioned in this user's manual are trademarks or registered trademarks of their respective companies.

Checking the Contents of the Package

Unpack the box and check the contents before using the product. If the product is different from which you have ordered, if any parts or accessories are missing, or if the product appears to be damaged, contact your sales representative.

List of Accessories

The product is provided with the following accessories according to the model and suffix codes (see the table below). Check that none of them are missing or damaged.

No	Item name	Part number	Qty	Remarks
1	Mounting Clamps	-	2	

Safety Precautions

The product and the instruction manual describe important information to prevent possible harm to users and damage to the property and to use the product safely.

Understand the following description (signs and symbols), read the text and Observe Descriptions.

DESCRIPTION OF SIGNS

	WARNING	<i>This indicates a danger that may result in death or serious injury if not avoided.</i>
	CAUTION	<i>This indicates a danger that may result in minor or moderate injury or only a physical damage if not avoided.</i>

LC5296-AT LC5296V-AT, and LC5248E-AT can be configured as PID or ON-OFF Controller.

To change configuration, following steps are required to follow.

From menu parameter settings if user enter 5296 Password in Pass menu in configuration menu then it will displays

Parameter (PV display)		Setting Name & Description	Default Value	Show if Only
Symbol	Name			
COP (COP)	Control Output Type	Select Controlling Type for Output <i>P id / onof</i> 0 : PID 1 : onof	<i>P id</i>	Enter Password 5296 from configuration menu parameter settings

1. In *conf* menu, *PASS* sub menu, if user enter '5296', sub menu will come *COP*: it has two options *P id* or *ONOF*.
2. Selected *COP* in above menu will be displayed on power on condition. Like PV: 5296 SV: tC-E then PV: *COP* SV: *ONOF*. If *COP*: *P id* is selected then PV: *COP* SV: PID.
3. For *COP* = PID, then in *conf*. mode, after *0t* menu, *COP* menu will come. With three option, *P*, *P I* or *P Id*.

On selection of PID / ON-OFF, only relevant parameters will be displayed in menu.

2. SPECIFICATIONS

2.1 Inputs

Analog Input	
Input Type	Thermocouple, RTD (Pt100), Current, Voltage
Display Range	Refer Table-2.1
Accuracy	\pm (0.25% of Full Span \pm 1 count) for T/C and RTD input. \pm (0.1% of Full Span \pm 1 count) for Linear input.
ADC Resolution	16 bits
Display Resolution	0.1°C / 1 Count
Sampling Rate	4 Samples/Sec
CJC Error	\pm 3.0 °C Max
Sensor open Detection	All inputs except 0-5V
Sensor Burnout current	0.25uA
RTD excitation current	0.166mA (Approx)
Allowable wiring resistance for RTD	Maximum 15 ohms/wire (Conductor resistance between three wires should be equal)
NMRR	> 40 dB
CMRR	> 120 dB
Temp-co	< 150ppm/°C
Input Impedance	> 1M Ω (Voltage Input) 250 Ω (Current Input)
Max Voltage	20VDC

Input type	Range
PT100 (0.1 °C)	-199.9 to 850.0 °C
PT100 (1 °C)	-200 to 850°C
E	-200 to 1000°C
J	-200 to 1200°C
K	-200 to 1372°C
T	-200 to 400°C
B	450 to 1800
R	0 to 1768°C
S	0 to 1768°C
*4-20mA / 1-5VDC, *0-20mA / 0-5VDC 0-10VDC	-1999 to 9999 (Field Scalable)

***Use external 250ohms, 0.1% for current Input**

2.2 Display & Keys

Model	Display	Specification
LC5296-AT	PV Display	4-Digit, 7-Segment, Red, Character height of 0.56"
	SV / Parameter Display	4-Digit, 7-Segment, Green, Character height of 0.40"
	Status Indication	Individual RED Led for Relay, SSR Output, Manual & Communication Status

LC5248E-AT	PV Display	4-Digit, 7-Segment, Red, Character height of 0.40"
	SV / Parameter Display	4-Digit, 7-Segment, Green, Character height of 0.28"
	Status Indication	Individual RED Led's for Relay Status, SSR Output, Manual & Communication Status
LC5296V-AT	PV Display	4-Digit, 7-Segment, Red, Character height of 0.36"
	SV / Parameter Display	4-Digit, 7-Segment, Green, Character height of 0.31"
	Status Indication	Individual RED Led's for Relay Status, SSR Output, Manual & Communication Status

2.3 Output Types

Output types are software selectable from the Key board or Modbus (LC5296-AT&LC5248E-ATOnly).

Model	Output Type	Description
LC5296-AT/LC5248E-AT/ LC5296V-AT	Relay Output	2 Relays <u>Relay-1</u> • For PID or ON-OFF Controlling. • Used as Alarm-1 Output if Output Type is Linear <u>Relay-2</u> • Alarm-2 Output
	SSR Output *	Voltage Pulse Output Available at Terminals of Relay-1
	Linear Output	Available at Terminals of Retransmission-1. Linear Output Type as per selection in Retransmission-1 Output Type.
	Motor position control without slide wire feedback	<u>Relay-1</u> As a Forward Relay <u>Relay-2</u> As a Reverse Relay

- Also, Output Direction [Direct (Cooling) /Reverse (Heating)] is selectable from software.
- * For LC5296-AT, LC5248E-AT, LC5296V-AT, at a time unit can support Relay or SSR Output. (Factory settable) (Specify in Order Code)

Relay Output	
Relays	1
Type	Single Change over Three Terminals (C, NO, NC)
Rating	2A @ 230VAC / 30VDC
Pulse Output (SSR)	
Output signal	Voltage Pulse Output
Output signal On-condition	11VDC or more
Off-condition	2VDC or less
Resolution	10 ms
Linear Output	
Output Signal	Voltage (0-5VDC, 1-5VDC, 0-10VDC) @3kΩ Min Current (4-20mADC, 0-20mADC) @500Ω Max

Retransmission Output	
Number of output	1 (@Retransmission-2)(For Linear Output Type) or *2 (@Retransmission-1&2)(For Relay, SSR or VPFN Output Type)
Output According to	Process Value
Output Signal	4-20mA/ 0-20mA/1-5VDC/ 0-5VDC / 0-10V DC
Load resistance	<500Ω >3KΩ
<ul style="list-style-type: none"> • For Current o/p • For Voltage o/p 	
Output accuracy	±0.25% of span

***Not applicable for LC5248E-AT, LC5296V-AT**

Alarm Output	
Number of Outputs	2 if Output Type is Linear(@Relay-1&2), 1 if Output Type is Relay or SSR(@Relay-2) Not Available if Output Type is VPFN Control relays are available as alarm outputs
Output signal	Three terminals (NC, NO, and C)
Purpose	Alarm output and others. (See Alarm and Digital outputs function)
Relay contact rating	250 V AC or 30 V DC, 2A (resistive load)

Loop Power Supply	
Supply Voltage	24VDC (±1V) @26mA with Inbuilt Short Circuit Protection
Minimum load resistance	800 ohms

2.4 Communication Details

Communication	
Interface	RS485 (2 Wire)
Protocol	Modbus-RTU
Baud rate	9600, 19200, 38400 bps

2.5 Power Supply

Standard	85-265VAC/ 100-300VDC
Optional	18-36VDC
Power consumption	<10 VA (LC5296-AT) <5 VA (LC5248E-AT)
Data backup	Non-volatile memory (can be written up to 100000 times)

Isolation (Withstanding voltage)

- Between primary terminals* and secondary terminals**:
At least 1500 V AC for 1 minute
- Between primary terminals* and grounding terminal:
At least 1500 V AC for 1 minute
- Between grounding terminal and secondary terminals**:
At least 1500 V AC for 1 minute
- Between secondary terminals**:
At least 500 V AC for 1 minute

* Primary terminals indicate power terminals and relay output terminals.

** Secondary terminals indicate analog I/O signal and Communication O/P.

Insulation resistance: 20MΩ or more at 500 V DC between power terminals and grounding terminal.

2.6 Environmental Conditions

TEMPCO	For Input to PV Display < 100ppm. FOR Display to Retransmission and Control output < 100ppm
Humidity	30% to 95% RH (Non-Condensing)
Instrument Warm-up Time	Approx. 15 minutes
Ambient temperature	0 to 55°C
Storage Temperature	0 to 80°C

3. PHYSICAL SPECIFICATIONS & MOUNTING DETAILS

3.1 LC5296-AT

Front Bezel	96 x 96 mm
Panel Cutout	92mm(+0.8) x 92mm(+0.8)
Depth Behind The Panel	65 mm with Terminal
Weight	300g Approx.
Encloser Material	ABS
Encloser Protection	IP20
Terminal Cable Size	2.5 mm ²

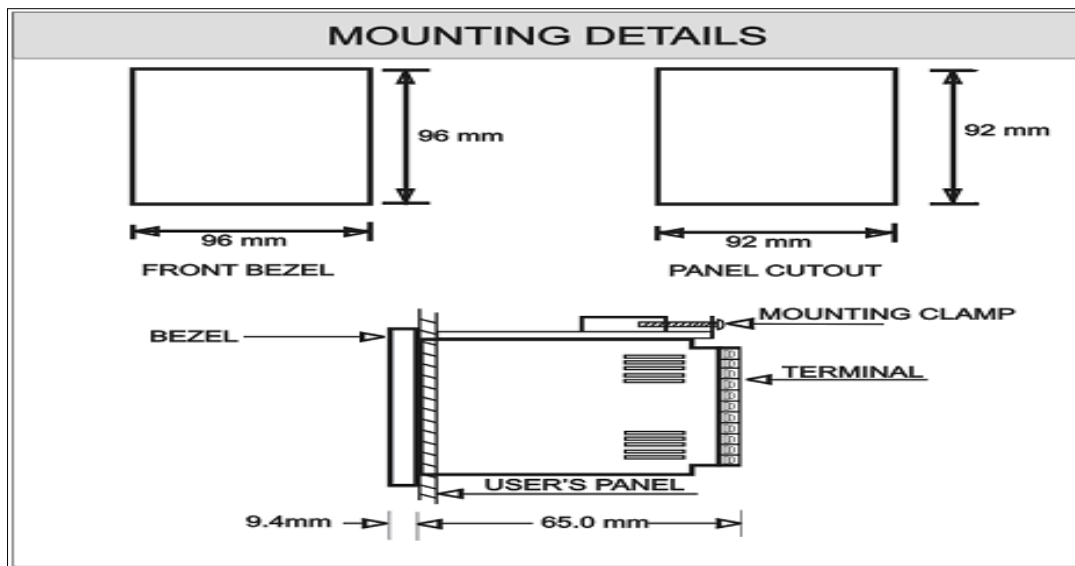

Fig 3.1: Mounting Details for LC5296-AT

3.3 LC5248E-AT

Front Bezel	48 x 48 mm
Panel Cutout	45 x 45 mm
Depth Behind The Panel	115mm
Weight	200g Approx.
Encloser Material	ABS
Encloser Protection	IP20
Terminal Cable Size	2.5 mm ²

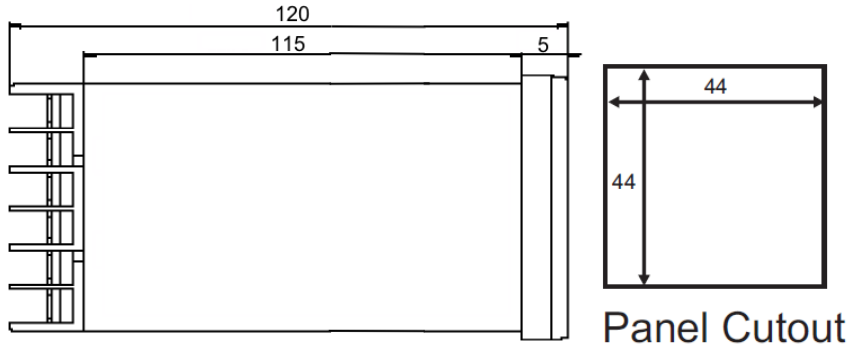

Fig 3.3: Mounting Details for LC5248E-AT

3.4 LC5296V-AT

Front Bezel	96 x 48 mm
Panel Cutout	92mm(+0.8) x 45mm(+0.6)
Depth Behind The Panel	75 mm with Terminal
Weight	300 g Approx.
Enclosure Material	Molded ABS
Enclosure Protection	IP20
Terminal Cable Size	2.5 mm ²

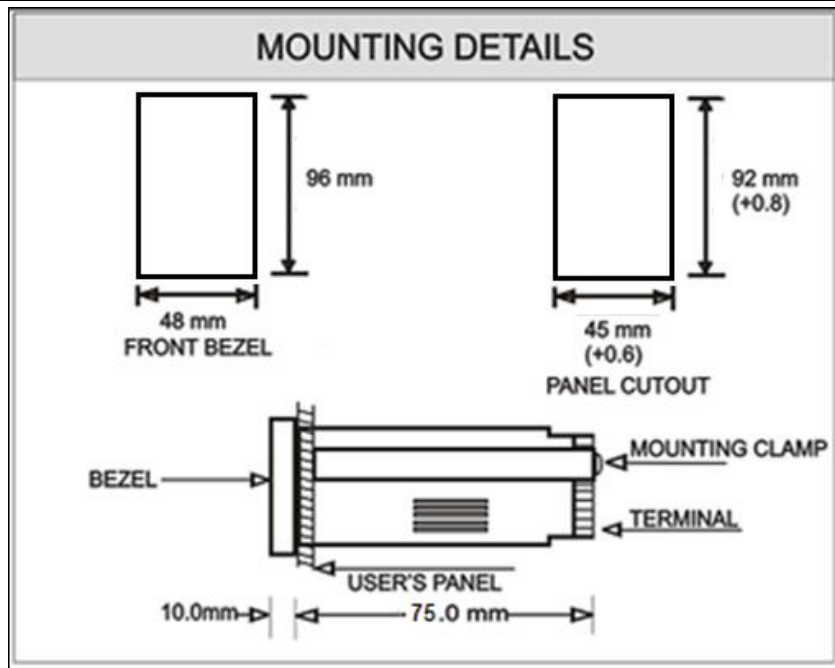

Fig 3.3: Mounting Details for LC5296V-AT

4. TERMINAL CONNECTIONS

4.1 LC5296-AT

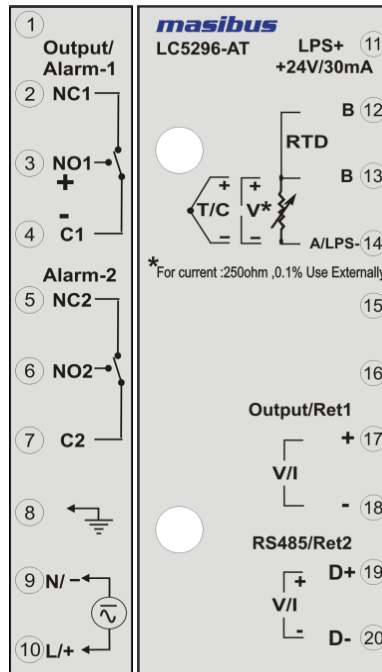

Fig 4.1: Terminal Connection Detail of LC5296-AT

Terminal No.	Description
2 (NC1) 3 (NO1) 4 (C1)	<ul style="list-style-type: none"> • For Relay-1 potential free Contacts (Use 230V -2A load) • PID/ On-Off Control o/p. • Alarm-1 o/p, if output type is Linear. • Forward Relay, if output type is Motor position control without slide wire feedback • Terminal 3,4:- SSR Pulse o/p.
5 (NC2) 6 (NO2) 7 (C2)	<ul style="list-style-type: none"> • For Relay-2 potential free Contacts (Use 230V -2A load) • Alarm-2 o/p. • Reverse Relay, if output type is Motor position control without slide wire feedback
8 (Earth)	Earth Connection
9 (N/-) 10 (L/+)	Power Supply Input
11 (LPS+)	24VDC Loop power supply Terminal 14 is ground Reference.
12	For RTD Input Only (Three wire Compensation).
13 (TC+ / V+) 14 (TC- / V- / LPS-)	For Thermocouple, RTD & Linear Input
17 (Linear Output+ /RTR1+) 18 (Linear Output- /RTR1-)	<ul style="list-style-type: none"> • For Retransmission-1 output • Linear type Control Output
19 (D+ / RTR2+) 20 (D- / RTR2-)	<ul style="list-style-type: none"> • For Retransmission-2 output • Modbus-RTU Communication Output

4.3 LC5248E-AT

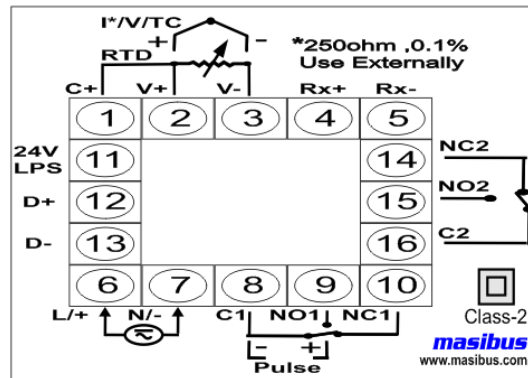

Fig 4.5: Terminal Connection Detail of LC5248E-AT

Terminal No.	Description
1	For RTD Input Only (Three wire Compensation).
2(TC+ / V+) 3(TC- / V- / LPS-)	For Thermocouple, RTD & Linear Input
4 (Rx1+) 5 (Rx1-)	<ul style="list-style-type: none"> For Retransmission-1 output
6 (N/-) 7 (L/+)	Power Supply Input
8 (C1) 9 (NO1) 10 (NC1)	<ul style="list-style-type: none"> For Relay-1 potential free Contacts (Use 230V -2A load) On-Off Control o/p.
11 (LPS+)	24VDC Loop power supply Terminal 14 is ground Reference.
12 (D+) 13 (D-)	<ul style="list-style-type: none"> Modbus-RTU Communication Output
14 (NC2) 15 (NO2) 16 (C2)	<ul style="list-style-type: none"> For Relay-2 potential free Contacts (Use 230V -2A load) On-Off Control o/p.

4.4 LC5296V-AT

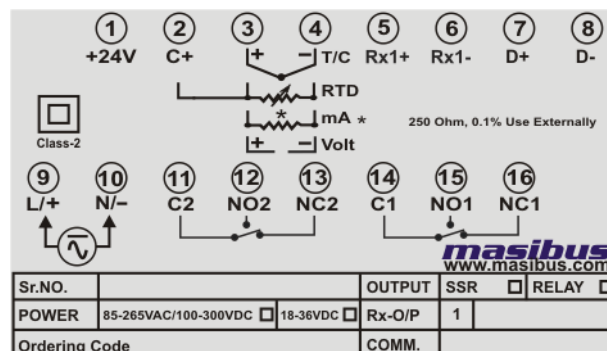

Fig 4.6: Terminal Connection Detail of LC5296V-AT

Terminal No.	Description
1 (LPS+)	24VDC Loop power supply Terminal 14 is ground Reference.
2	For RTD Input Only (Three wire Compensation).
3 (TC+ / V+)	For Thermocouple, RTD & Linear Input

4 (TC- / V- / LPS-)	
5 (Rx1+) 6 (Rx1-)	<ul style="list-style-type: none"> • For Retransmission-1 output • Linear type Control Output
7 (D+) 8 (D-)	<ul style="list-style-type: none"> • Modbus-RTU Communication Output
9 (L/+) 10 (N/-)	Power Supply Input
11 (NC2) 12 (NO2) 13 (C2)	<ul style="list-style-type: none"> • For Relay-2 potential free Contacts (Use 230V -2A load) • On-Off Control o/p.
14 (C1) 15 (NO1) 16 (NC1)	<ul style="list-style-type: none"> • For Relay-1 potential free Contacts (Use 230V -2A load) • PID/ On-Off Control o/p. • Alarm-1 o/p, if output type is Linear. • Terminal 3,4:- SSR Pulse o/p.

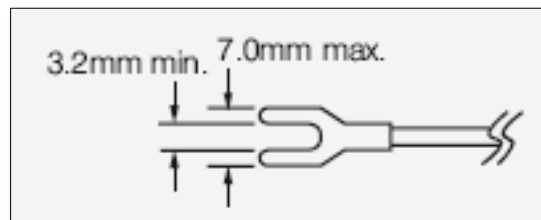

Fig 4.3:Lead Termination Detail

4.4 How to connect wires

Before carrying out wiring, turn off the power to the controller and check that the cables to be connected are not alive because there is a possibility of electric shock.

NOTE:

- ✓ All wiring must confirm to appropriate standards of good practice and local codes and regulations. Wiring must be suitable for Voltage, Current and temperature rating of the system.
- ✓ Provide power from a single-phase instrument power supply. If there is a lot of noise in the power line, insert an insulating transformer into the primary side of the line and use a line filter on the secondary side. Do not place the primary and secondary power cables close to each other.
- ✓ For thermocouple input, use shielded compensating lead wires for wiring. For RTD input, use shielded wires that have low conductor resistance and cause no significant differences in resistance between the three wires.
- ✓ Use repeater after each set of 32 instruments connected in RS-485 Communication.
- ✓ Unused terminals should not be used as jumper points as they may be internally connected, which may cause damage to the unit.
- ✓ Unused control terminals should not be used as jumper points as they may be internally connected, which may cause damage to the unit.
- ✓ Use >250V-1Amp Cable for Power Supply.
- ✓ Supply voltage must be below maximum voltage rating specified on the label.



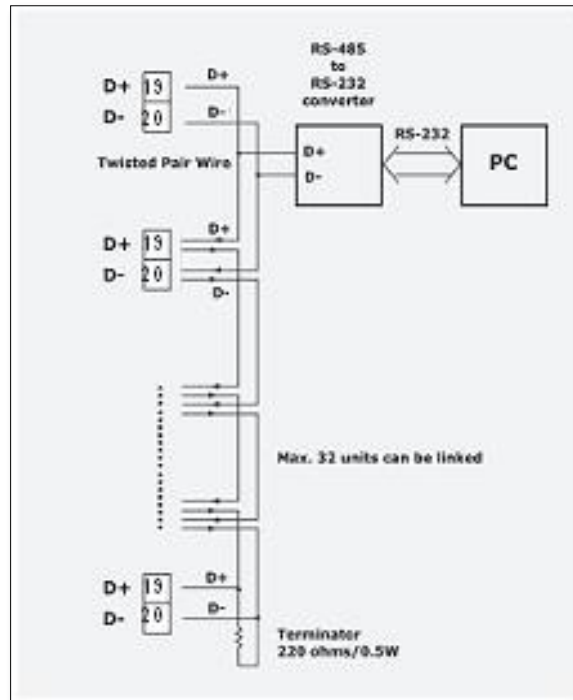
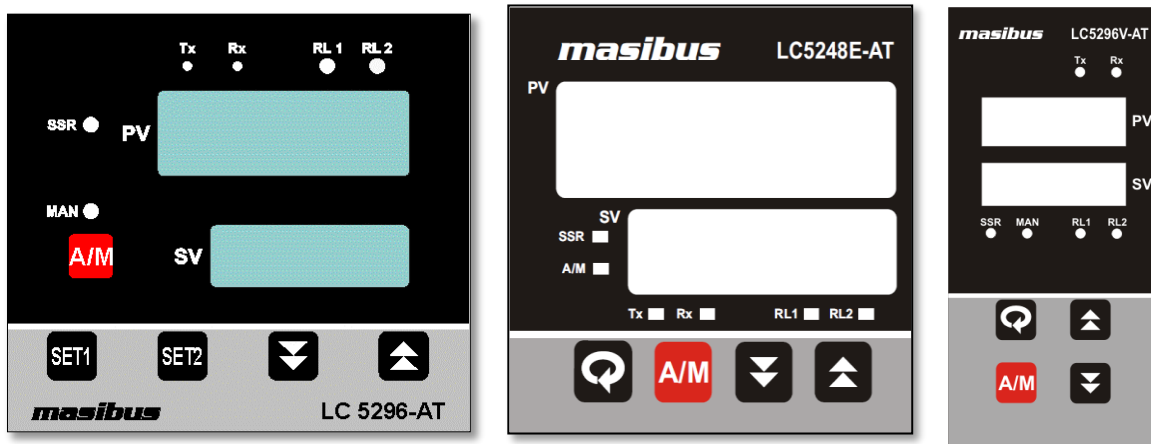

Fig 4.4: RS485 Connection Details

5. FRONT PANEL DETAILS





5.1 Front Panel Description of LC5296-AT

Name of Part	Symbol	Function
Increment Key		<ul style="list-style-type: none"> Increment the Value of any Parameter. Shows ambient value for T/C Input in RUN mode. In Manual Mode this key is used to Increment the %Power.
Decrement Key		<ul style="list-style-type: none"> Decrement the Value of any Parameter. Shows %Power value if Device is in Auto Mode in RUN mode. In Manual Mode this key is used to Decrement the %Power.

SET-1 Key (Menu / Enter Key)		<ul style="list-style-type: none"> • For Linear Output, Shows Alarm Set Point-1(A1.SP), if pressed in RUN mode. And if pressed for few seconds shows Control Set Point-1(C1.SP). • For Other Output Type, shows Control Set Point-1(C1.SP), if pressed in RUN mode. • In Sub Menu it can be used to get to the next Parameter. • It is also used to save the parameters to nonvolatile memory, when user setting a proper data by Increment and decrement key for parameter configuration.
SET-2 Key		<ul style="list-style-type: none"> • Shows Alarm Set Point-2(A2.SP), if pressed in RUN mode. • Shows Sok.t(Run/stop) if pressed two times in RUN mode.
Auto/Man ual Key		<ul style="list-style-type: none"> • It is used to switch between Auto to Manual mode and Manual to Auto mode if pressed for at least 2 sec if function key is A/M. • Shows remaining soak time when pressed if function key is selected SOK.T.
PV (Process Value) Display	PV	<ul style="list-style-type: none"> • 4 digital 0.56 inch RED Display • Display process value. • Display parameter name when user set parameter. • Display error message when an error occurs.
SV (Set Value) Display	SV	<ul style="list-style-type: none"> • 4 digital 0.4 inch GREEN • Display set value. • Display parameter value of parameter in process value field when user set parameter. • Display control output value when in manual mode.
Relay-1 Indication	RL1	<ul style="list-style-type: none"> • ON when Relay-1 is energized & OFF otherwise.
Relay-2 Indication	RL2	<ul style="list-style-type: none"> • ON when Relay-2 is energized & OFF otherwise.
SSR Indication	SSR	<ul style="list-style-type: none"> • SSR ON status.
MANUAL Indication	MAN	<ul style="list-style-type: none"> • ON when unit is in Manual mode. • OFF when unit in Auto Mode.
TX Indication	Tx	<ul style="list-style-type: none"> • ON when device is transmitting some Data (RS-485).
RX Indication	Rx	<ul style="list-style-type: none"> • ON when device is receiving some Data (RS-485).

5.3 Front Panel Description of LC5248E-AT/LC5296V-AT

Name of Part	Symbol	Function
Increment Key		<ul style="list-style-type: none"> • Increment the Value of any Parameter. • Shows ambient value for T/C Input in RUN mode. • In Manual Mode this key is used to Increment the %Power.
Decremen t Key		<ul style="list-style-type: none"> • Decrement the Value of any Parameter. • Shows %Power value if Device is in Auto Mode in RUN mode. • In Manual Mode this key is used to Decrement the

		%Power.
SET-1 Key/ SET-2 Key (Menu / Enter Key)		<ul style="list-style-type: none"> • For Linear Output, Shows Alarm Set Point-1(A1.SP), if pressed one time in RUN mode. • For Other Output Type, shows Control Set Point-1(C1.SP), if pressed in RUN mode. • In Sub Menu it can be used to get to the next Parameter. • It is also used to save the parameters to nonvolatile memory, when user setting a proper data by Increment and decrement key for parameter configuration. • Shows Alarm Set Point-2(A2.SP), if pressed two times in RUN mode. Shows Sok.t(Run/stop) if pressed three times in RUN mode.
Auto/Manual Key		<ul style="list-style-type: none"> • It is used to switch between Auto to Manual mode and Manual to Auto mode if pressed for at least 2 sec if function key is A/M. • Shows remaining soak time when pressed if function key is selected SOK.T.
PV (Process Value) Display	PV	<ul style="list-style-type: none"> • 4 digital 0.40 inch RED Display(for LC5248E-AT) • 4 digital 0.36 inch RED Display(for LC5296V-AT) • Display process value. • Display parameter name when user set parameter • Display error message when an error occurs.
SV (Set Value) Display	SV	<ul style="list-style-type: none"> • 4 digital 0.28 inch GREEN Display(for LC5248E-AT) • 4 digital 0.31 inch GREEN Display(for LC5296V-AT) • Display set value. • Display parameter value of parameter in process value field when user set parameter. • Display control output value when in manual mode.
Relay-1 Indication	RL1	<ul style="list-style-type: none"> • ON when Relay-1 is energized & OFF otherwise.
Relay-2 Indication	RL2	<ul style="list-style-type: none"> • ON when Relay-2 is energized & OFF otherwise.
SSR Indication	SSR	<ul style="list-style-type: none"> • SSR ON status.
MANUAL Indication	MAN	<ul style="list-style-type: none"> • ON when unit is in Manual mode. • OFF when unit in Auto Mode.
TX Indication	Tx	<ul style="list-style-type: none"> • ON when device is transmitting some Data (RS-485).
RX Indication	Rx	<ul style="list-style-type: none"> • ON when device is receiving some Data (RS-485).

6. MENU LAYOUT

6.1 Menu Layout for LC5296-AT

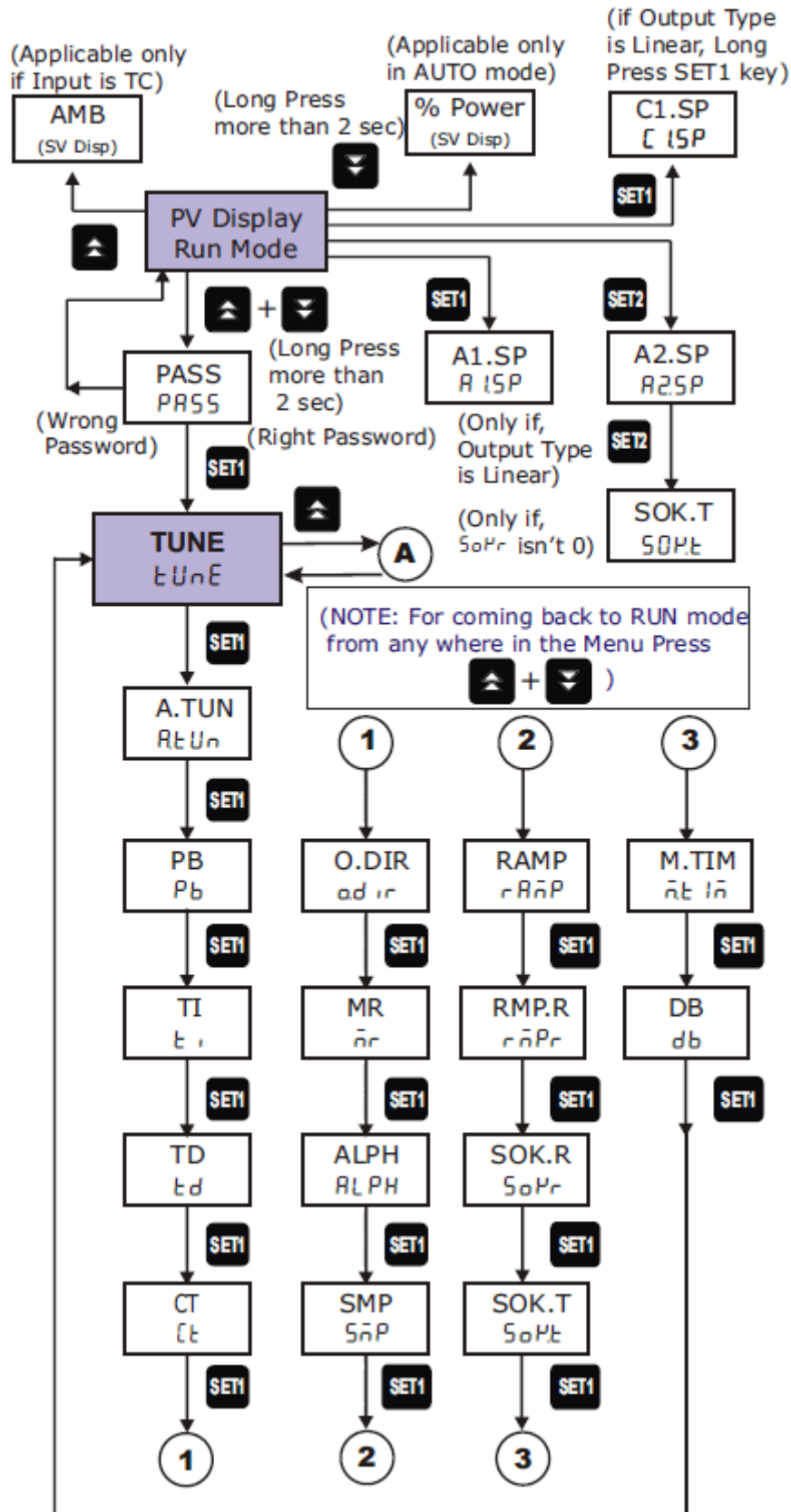

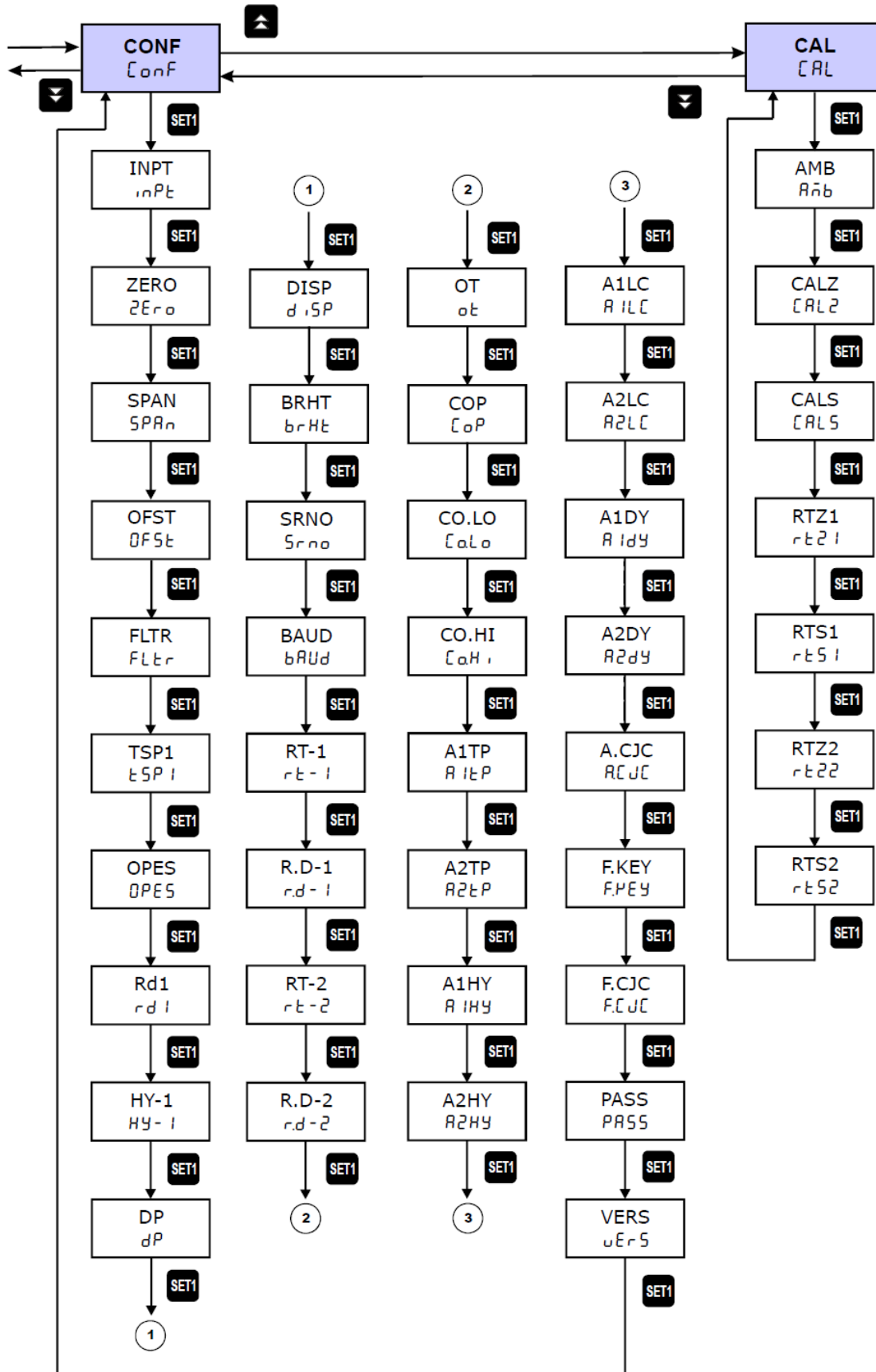

6.2 Menu Layout for LC5248E-AT/LC5296V-AT

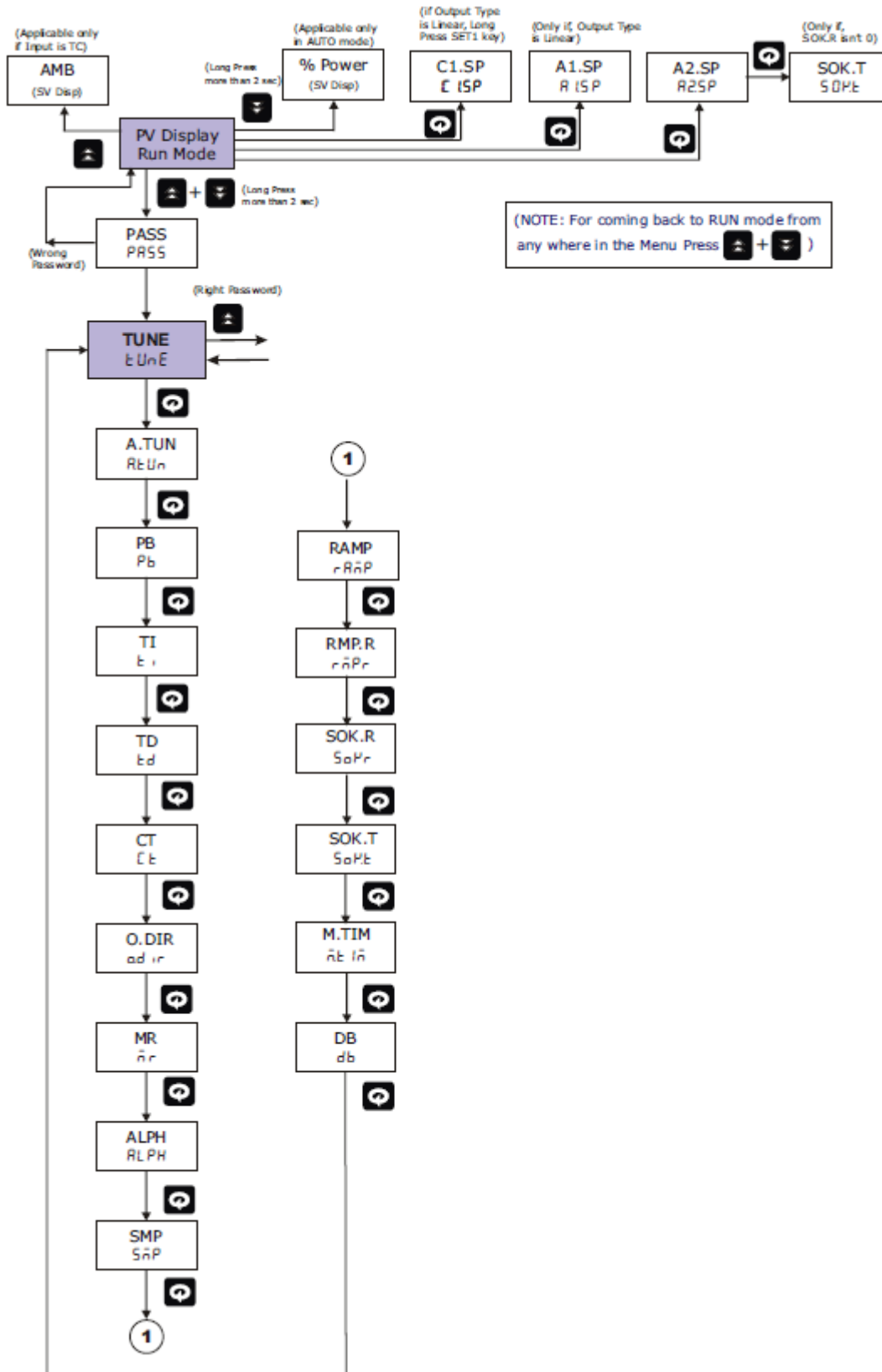

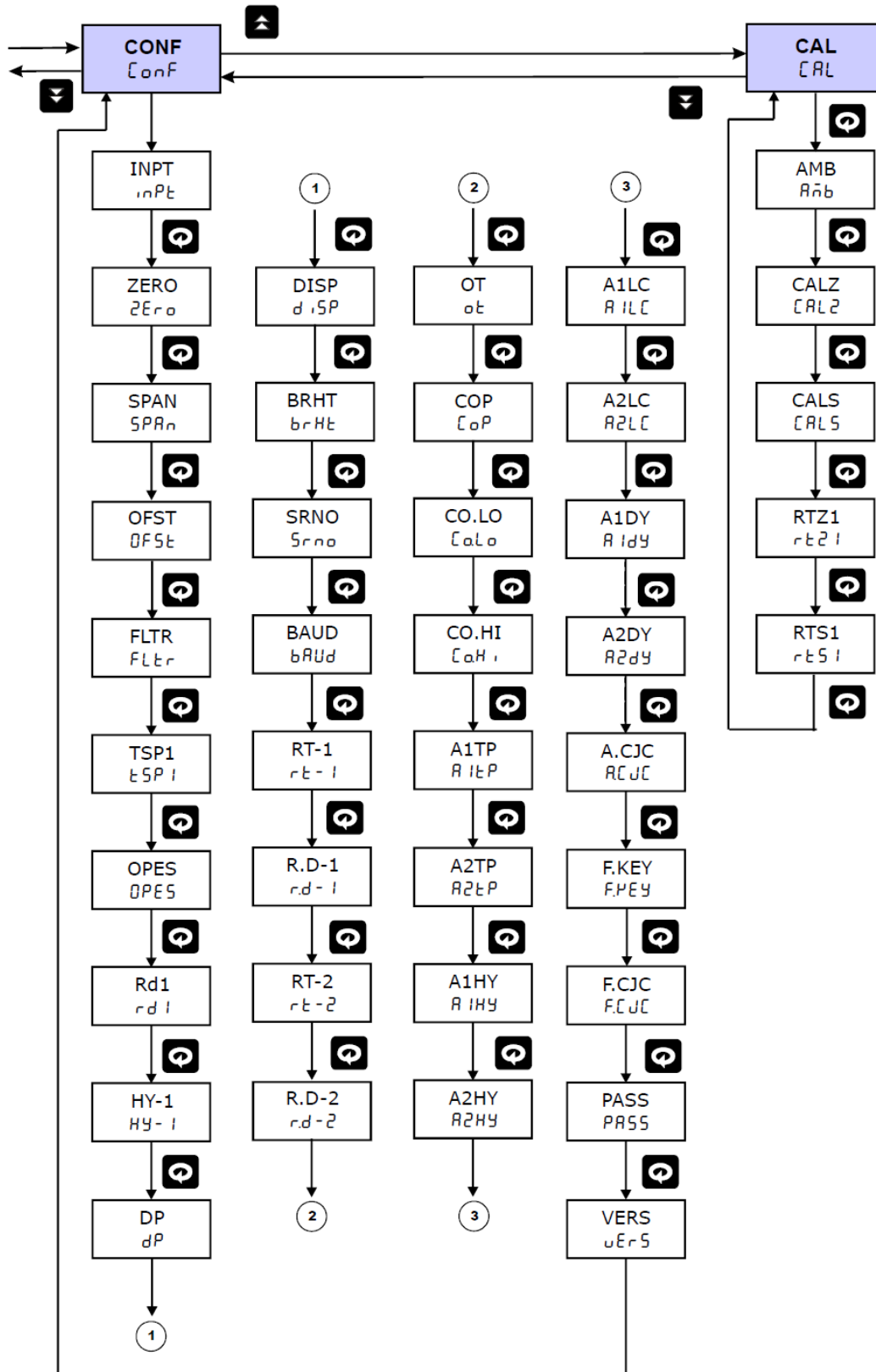

6.3 RUN Time Indication/Function

Following parameters can view or change during run time.

- Press Decrement key to show percentage power Auto Mode (0.0 to 100.0%)
- For Thermocouple input type, Press Increment key to show ambient temperature.
- During manual mode, Increment key and Decrement Key will use to modify the percentage power.
- Press  to toggle between AUTO & MANUAL mode or display time.

6.4 Set Point Setting

6.4 Set Point Setting Set Point Setting:				
Parameter (PV display)		Setting name and description	Default value	Shows only if
Symbol	Name			
C1.SP (C1.SP)	Control Set Point 1	Range Depending on PV sensor type selected	100	-
A1.SP (A1.SP)	Alarm Set Point 1	Range Depending on PV sensor type selected	100	Output Type is LIN(Linear)
A2.SP (A2.SP)	Alarm Set Point 2	Range Depending on PV sensor type selected	100	-
SOKT* (SOKT)	Soak Run/stop	To Run/Stop Soak time	stop	Soak rate (Soak.r) is not 0

*Last decimal point of PV display "ON", indicates RUN.

6.5 AUTO TUNE MODE

AUTOTUNE PARAMETERS				
Parameter (PV display)		Setting Name & Description	Default Value	Show if Only
Symbol	Name			
A.TUN (A.tUn)	Auto Tune	Start / Stop Auto Tuning Process YES/NO 0 : NO (Stop Auto Tuning) 1 : YES (Start Auto Tuning)	NO	Control Type(COP) is PI or PID
PB (Pb)	Proportional Band	Adjust Proportional Band 0 to 9999 or 0.0 to 999.9	10.0	Control Type(COP) is P or PI or PID
TI (tI)	Integral Time	Adjust Integral Time 0 to 1000	60	Control Type(COP) is PI or PID
TD (tD)	Derivative Time	Adjust Derivative Time 0 to 180	0	Control Type(COP) is PID

CT (ζt)	Cycle Time	Adjust Cycle Time For, SSR o/p: (1 – 60 sec) Relay o/p: (10 – 300 sec)	10																	
O.DIR ($o.d.ir$)	Output Direction	Set Output Direction $d ir/rEu$ 0 : REV (REVERSE) 1 : DIR (Direct)	0 (REV)	Control Type(COP) is P or PI or PID																
MR ($\bar{m}r$)	Manual Reset	Adjust Manual Reset Value It is used to shift P Band for critical Controlling situations. -50% to 50% of PB EX. If PB = 50, SP = 100, O.DIR = REV MR = OMR = 25 <table border="1" style="margin-left: 20px;"> <tr> <td>PV</td> <td>% POWER</td> <td>PV</td> <td>%POWER</td> </tr> <tr> <td><= 75</td> <td>100 %</td> <td><= 100</td> <td>100 %</td> </tr> <tr> <td>100</td> <td>50 %</td> <td>125</td> <td>50 %</td> </tr> <tr> <td>>= 125</td> <td>0 %</td> <td>>= 150</td> <td>0 %</td> </tr> </table>	PV	% POWER	PV	%POWER	<= 75	100 %	<= 100	100 %	100	50 %	125	50 %	>= 125	0 %	>= 150	0 %	0	Control Type(COP) is P or PI or PID
PV	% POWER	PV	%POWER																	
<= 75	100 %	<= 100	100 %																	
100	50 %	125	50 %																	
>= 125	0 %	>= 150	0 %																	
ALPH ($\bar{A}LPH$)	Sampling Rate	Adjust Sampling Rate Its acts like Derivative Factor. It is used to decrease effect of D term in PID output for some critical operating condition 0.01 to 1.00	1.00	Control Type(COP) is PID																
SMP ($\bar{S}mP$)	Sampling Period	Set Sampling Period. $200 / 500 / 1$ 0 : 200 ms 1 : 500 ms 2 : 1 sec	0 (200 ms)	Control Type(COP) is PID																
RAMP ($r\bar{A}mP$)	Ramp Rate type	$nonE/\bar{n} in .r/hr .r$ 0:none 1:min.r 2:hr.r	None	-																
Rmp.R ($r\bar{m}P .r$)	Ramp rate value	0.1 to 999.9 Degree per minutes or hour	0.1	-																
SOK.R ($\bar{S}OP .r$)	Soak rate	0.00 to 99.59 HH.MM	0.00	-																
SOK.T ($\bar{S}OP .t$)	Soak type	$S .hod/5 .r5t$ 0:s.hod 1:s.rst	s.rst	-																
M.TIM ($\bar{m} .t i\bar{n}$)	Motor Travel Time	10 to 500 sec	60	Output type is VPFN																
db ($\bar{d}b$)	Dead Band	0.1 to 50.0	1.0	Output type is VPFN																

6.6 CONFIGURATION MODE

CONFIGURATION PARAMETERS													
Parameter (PV display)		Setting Name & Description	Default Value	Show if Only									
Symbol	Name												
INPT ($inPt$)	INPUT Type	Set PV Input Type $tC E/tC J /tC P /tC t /tC b /tC r /tC S /rtd .1 /rtd/0-5u /1-5u /0-10$ <table border="1" style="margin-left: 20px;"> <tr> <th>Value</th> <th>Input Type</th> <th>Range</th> </tr> <tr> <td>0</td> <td>TC E</td> <td>-200 to 1000 °C</td> </tr> <tr> <td>1</td> <td>TC J</td> <td>-200 to 1200 °C</td> </tr> </table>	Value	Input Type	Range	0	TC E	-200 to 1000 °C	1	TC J	-200 to 1200 °C	TC E	
Value	Input Type	Range											
0	TC E	-200 to 1000 °C											
1	TC J	-200 to 1200 °C											

		<table border="1"> <tr><td>2</td><td>TC K</td><td>-200 to 1372 °C</td></tr> <tr><td>3</td><td>TC T</td><td>-200 to 400 °C</td></tr> <tr><td>4</td><td>TC B</td><td>450 to 1800 °C</td></tr> <tr><td>5</td><td>TC R</td><td>0 to 1768 °C</td></tr> <tr><td>6</td><td>TC S</td><td>0 to 1768 °C</td></tr> <tr><td>7</td><td>RTD.1</td><td>-199.9 to 850.0 °C</td></tr> <tr><td>8</td><td>RTD</td><td>-200 to 850 °C</td></tr> <tr><td>9</td><td>0-5 V / 0-20 mA*</td><td rowspan="3">-1999 to 9999</td></tr> <tr><td>10</td><td>1-5 V / 4-20 mA*</td></tr> <tr><td>11</td><td>0-10 V</td></tr> </table> <p>*Use external 250ohms,0.1% for current input</p>	2	TC K	-200 to 1372 °C	3	TC T	-200 to 400 °C	4	TC B	450 to 1800 °C	5	TC R	0 to 1768 °C	6	TC S	0 to 1768 °C	7	RTD.1	-199.9 to 850.0 °C	8	RTD	-200 to 850 °C	9	0-5 V / 0-20 mA*	-1999 to 9999	10	1-5 V / 4-20 mA*	11	0-10 V		
2	TC K	-200 to 1372 °C																														
3	TC T	-200 to 400 °C																														
4	TC B	450 to 1800 °C																														
5	TC R	0 to 1768 °C																														
6	TC S	0 to 1768 °C																														
7	RTD.1	-199.9 to 850.0 °C																														
8	RTD	-200 to 850 °C																														
9	0-5 V / 0-20 mA*	-1999 to 9999																														
10	1-5 V / 4-20 mA*																															
11	0-10 V																															
ZERO (ZERO)	Zero	<p>Automatically change to the Input Lower Range with changing of Input Type (Refer Above Table)</p> <p>Can be set to any value within the Input Range & less the SPAN Value.</p>	-200 (If TC E)																													
SPAN (SPAN)	Span	<p>Automatically change to the Input Higher Range with changing of Input Type (Refer Above Table)</p> <p>Can be set to any value within the Input Range & greater the ZERO Value.</p>	1000 (If TC E)																													
OFST (OFST)	offset	<p>Offset Value</p> <table border="1"> <thead> <tr><th>Input type</th><th>range</th></tr> </thead> <tbody> <tr><td>RTD/ Thermocouple</td><td>-100.0°C to +100.0°C</td></tr> <tr><td>Linear</td><td>-1000 to +1000</td></tr> </tbody> </table>	Input type	range	RTD/ Thermocouple	-100.0°C to +100.0°C	Linear	-1000 to +1000	0.0																							
Input type	range																															
RTD/ Thermocouple	-100.0°C to +100.0°C																															
Linear	-1000 to +1000																															
FLTR (FLTR)	Filter	<p>Enable or Disable Filter for PV Input</p> <p>YES /no</p> <p>0 : NO 1 : YES</p>	1 (YES)																													
TSP1 (TSP1)	Type of Set Point	<p>Set Type of Set Point</p> <p>L-on/H-on</p> <p>0 : L-ON (Lower ON) 1 : H-ON (Higher ON)</p> <p>Refer ON-OFF Control on Page:32</p>	0 (L-ON)	Control Type (COP) is ON-OFF.																												
OPES (OPES)	OPEN Sensor Status	<p>Set Control O/P & Retransmission state when Input OPEN condition.</p> <p>down/UP</p> <p>0 : DOWN 1 : UP</p> <p>Refer Page:44</p>	1 (UP)																													
RD1 (RD1)	Relay Delay (For Relay-1)	<p>Relay Delay is amount of time (in sec), that Relay will wait before getting ON after the ON condition occurs.</p> <p>1 to 99 sec</p>	1 sec	Control Type (COP) is ON-OFF.																												
HY-1 (HY-1)	Hysteresis – 1 (For Relay-1)	<p>Hysteresis Value (in °C) for Relay-1 during ON-OFF type Control.</p> <table border="1"> <tr><td>1 to 100</td><td>TC & RTD Input</td></tr> <tr><td>0.1 to 100.0</td><td>RTD.1 Input</td></tr> <tr><td>1 to 100</td><td>Linear Input with DP=0</td></tr> <tr><td>0.1 to 100.0</td><td>Linear Input with DP=1</td></tr> <tr><td>0.01 to 10.00</td><td>Linear Input with DP=2</td></tr> <tr><td>0.001 to 1.000</td><td>Linear Input with DP=3</td></tr> </table>	1 to 100	TC & RTD Input	0.1 to 100.0	RTD.1 Input	1 to 100	Linear Input with DP=0	0.1 to 100.0	Linear Input with DP=1	0.01 to 10.00	Linear Input with DP=2	0.001 to 1.000	Linear Input with DP=3	1	Control Type (COP) is ON-OFF.																
1 to 100	TC & RTD Input																															
0.1 to 100.0	RTD.1 Input																															
1 to 100	Linear Input with DP=0																															
0.1 to 100.0	Linear Input with DP=1																															
0.01 to 10.00	Linear Input with DP=2																															
0.001 to 1.000	Linear Input with DP=3																															

DP (dP)	Decimal Point	Set position of Decimal Point on Display. 0 /0 .0 /0 .00 /0 .000 *0 : 0 *1 : 0.0 2 : 0.00 3 : 0.000	1	Input Type is Linear, *if input type is RTD or TC
DISP (d,SP)	Display Set Point	Set which Set Point to shown in SV display in RUN mode while device is in Auto Mode C 1.SP /A2.SP /A1.SP / 5oP .t 0 : C1.SP (Control Set Point 1) 1 : A2.SP (Alarm Set Point 2) 2 : A1.SP (Alarm Set Point 1) 3: SOK.T (Remaining soak time)	0	Output Type is Relay or SSR then A1.SP will not appear.
BRHT (brHt)	Brightness	Adjust Brightness of the 7-segment Display. 10 to 100	100	
SRNO (Srno)	Serial No.	Unit ID for Modbus-RS485 Communication 1 to 247	1	
BAUD (bAud)	Baud Rate	Set Modbus RS485 Communication Baud Rate 9600 / 19.2K / 38.4K 0 : 9600 (9600 bps) 1 : 19.2K (19200 bps) 2 : 38.4K (38400 bps)	0 (9600)	
RT-1 (rt-1)	Retransmission 1 Type	Retransmission-1 Output Type This output is according to PV input. Zero & Span acts as Min & Max value of retransmission o/p scale respectively. 0-5v / 1-5v /0- 10v /4-20 /0-20 0 : 0-5V 1 : 1-5V 2 : 0-10V 3 : 4-20mA 4 : 0-20mA Voltage or Current is Jumper Selectable from the Hardware.	3 (4-20mA)	
R.D-1 (r.d-1)	Retransmission-1 Direction	Set Direction for the Retransmission Output-1 rEv /d ir 0 : REV (REVERSE) 1 : DIR (DIRECT) EX. If i/p is RTD.1,ZERO=0,SPAN=600, RTR.1=4-20mA& RT.D.1=DIR when PV = 0, RTR o/p = 4mA PV = 300, RTR o/p = 12mA PV = 600, RTR o/p = 20mA RT.D.1=REV when PV = 0, RTR o/p = 20mA PV = 300, RTR o/p = 12mA PV = 600, RTR o/p = 4mA Refer Retransmission o/p table on Page 44 for more info.	1 (DIRECT)	OT(Output Type) is Relay / SSR
*RT-2 (rt-2)	Retransmission 2 Type	Retransmission-2 Output Type This output is according to PV input. Zero & Span acts as Min & Max value of retransmission o/p scale respectively. 0-5v / 1-5v /0- 10v /4-20 /0-20 0 : 0-5V 1 : 1-5V 2 : 0-10V 3 : 4-20mA 4 : 0-20mA Voltage or Current is Jumper Selectable from the Hardware.	3 (4-20mA)	

<p>* R.D-2 (<i>r .d-2</i>)</p>	<p>Retransmission-2 Direction</p>	<p>Set Direction for the Retransmission Output-2 <i>rEd ir</i> 0 : REV (REVERSE) 1 : DIR (DIRECT)</p>	<p>1 (DIRECT)</p>													
<p>OT (<i>ot</i>)</p>	<p>Output Type</p>	<p>Output Type <i>rELy /SSr/L in</i> 0 : RELY (Relay) 1 : SSR (Voltage Pulse Output) 2 : LIN (Linear) 3 : VPFN (Motor position control without slide wire feedback) Device can support RELAY or SSR output once at a time. (Factory Settable) ** Device can support Control output type <i>P Id</i> or <i>onof</i> .(Factory Settable)</p>	<p>0 (Relay)</p>	<p>**VPFN, LIN and SSR option will not appear if COP(Control Type) is ON-OFF</p>												
<p>COP (<i>CoP</i>)</p>	<p>Control Output Type</p>	<p>Select Controlling Type for Output <i>P /P i /P id</i> 0 : P (Proportional Control) 1 : PI 2 : PID</p>	<p>0 (P Type)</p>	<p>Control output type is PID</p>												
<p>CO.LO (<i>Co .Lo</i>)</p>	<p>Control Output Low Limit in %</p>	<p>Control Output Low Limit in %. 0.0 to 100.0 % (It will be always less then CO.HI)</p>	<p>0.0</p>	<p>Control output type is PID</p>												
<p>CO.HI (<i>Co .Hi</i>)</p>	<p>Control Output High Limit in %</p>	<p>Control Output High Limit in %. 0.0 to 100.0 % (It will be always greater then CO.LO)</p>	<p>100.0</p>	<p>Control output type is PID</p>												
<p>A1TP (<i>A1tP</i>)</p>	<p>Alarm Type – 1</p>	<p>Refer ALARM Type Table on Page.39 0 to 15</p>	<p>6 (PV.A.L.)</p>	<p>Output Type is LIN(Linear)</p>												
<p>A2TP (<i>A2tP</i>)</p>	<p>Alarm Type – 2</p>	<p>Refer ALARM Type Table on Page.39 0 to 15</p>	<p>6 (PV.A.L.))</p>	<p>Output Type is not VPFN</p>												
<p>A1HY (<i>A1Hy</i>)</p>	<p>Alarm 1 Hysteresis</p>	<p>Set Hysteresis(in °C) for Alarm-1</p> <table border="1" data-bbox="523 1299 1066 1462"> <tr><td>1 to 100</td><td>TC & RTD Input</td></tr> <tr><td>0.1 to 100.0</td><td>RTD.1 Input</td></tr> <tr><td>1 to 100</td><td>Linear Input with DP=0</td></tr> <tr><td>0.1 to 100.0</td><td>Linear Input with DP=1</td></tr> <tr><td>0.01 to 10.00</td><td>Linear Input with DP=2</td></tr> <tr><td>0.001 to 1.000</td><td>Linear Input with DP=3</td></tr> </table>	1 to 100	TC & RTD Input	0.1 to 100.0	RTD.1 Input	1 to 100	Linear Input with DP=0	0.1 to 100.0	Linear Input with DP=1	0.01 to 10.00	Linear Input with DP=2	0.001 to 1.000	Linear Input with DP=3	<p>1</p>	<p>Output Type is LIN(Linear)</p>
1 to 100	TC & RTD Input															
0.1 to 100.0	RTD.1 Input															
1 to 100	Linear Input with DP=0															
0.1 to 100.0	Linear Input with DP=1															
0.01 to 10.00	Linear Input with DP=2															
0.001 to 1.000	Linear Input with DP=3															
<p>A2HY (<i>A2Hy</i>)</p>	<p>Alarm 2 Hysteresis</p>	<p>Set Hysteresis(in °C) for Alarm-2</p> <table border="1" data-bbox="523 1516 1066 1680"> <tr><td>1 to 100</td><td>TC & RTD Input</td></tr> <tr><td>0.1 to 100.0</td><td>RTD.1 Input</td></tr> <tr><td>1 to 100</td><td>Linear Input with DP=0</td></tr> <tr><td>0.1 to 100.0</td><td>Linear Input with DP=1</td></tr> <tr><td>0.01 to 10.00</td><td>Linear Input with DP=2</td></tr> <tr><td>0.001 to 1.000</td><td>Linear Input with DP=3</td></tr> </table>	1 to 100	TC & RTD Input	0.1 to 100.0	RTD.1 Input	1 to 100	Linear Input with DP=0	0.1 to 100.0	Linear Input with DP=1	0.01 to 10.00	Linear Input with DP=2	0.001 to 1.000	Linear Input with DP=3	<p>1</p>	<p>Output Type is not VPFN</p>
1 to 100	TC & RTD Input															
0.1 to 100.0	RTD.1 Input															
1 to 100	Linear Input with DP=0															
0.1 to 100.0	Linear Input with DP=1															
0.01 to 10.00	Linear Input with DP=2															
0.001 to 1.000	Linear Input with DP=3															
<p>A1LC (<i>A1Lc</i>)</p>	<p>Alarm 1 Logic</p>	<p>Set Logic for Alarm-1 <i>norñ /FLSF</i> 0 : NORM (Normal) 1 : FLSF (Fail-Safe) Page. 37 shows operation diagram of different alarm Type for Alarm Logic NORM (Normal). For Fail-Safe Logic Alarm will work completely opposite to Normal behavior. (i.e. for any particular condition when Relay is ON for Normal logic, for that condition relay will OFF for Fail-Safe Logic & vice-versa)</p>	<p>0 (Normal)</p>	<p>Output Type is LIN(Linear)</p>												

A2LC (A2LC)	Alarm 2 Logic	Set Logic for Alarm-2 norm /FLSF 0 : NORM (Normal) 1 : FLSF (Fail-Safe)	0 (Normal)	Output Type is not VPFN
A1DY (A1DY)	Alarm 1 Delay	Alarm Delay is amount of time (in sec), that Relay-1 will wait before getting ON after the alarm condition occurs. 1 to 99 sec	1	Output Type is LIN(Linear)
A2DY (A2DY)	Alarm 2 Delay	Alarm Delay is amount of time (in sec), that Relay-2 will wait before getting ON after the alarm condition occurs. 1 to 99 sec	1	Output Type is not VPFN
A.CJC (A.CJC)	Auto Cold Junction Compensation	Select Auto Cold Junction Compensation required or not for TC input Type. no /YES 0 : NO 1 : YES	1 (YES)	Input Type is TC
F.CJC (F.CJC)	Fix cold junction Compensation	Set Fix cold junction Compensation value. 0 to 60.0 °C	0.0	Input Type is TC & A.CJC is NO
F.KEY (F.KEY)	Function Key	Select A/M or Soak time A-n/SOP.t 0 : A-M 1 : SOK.T	SOK.T	Control output type is PID
PASS (PASS)	Password	Set Device Password 0 to 9999	1	
VERS (VERS)	Version	Shows the Version of the Current Firmware	-	

* Not applicable for LC5248E-AT, LC5296V-AT

6.7 CALIBRATIONMODE

CALIBRATION PARAMETERS				
Parameter (PV display)		Setting Name & Description	Default Value	Show if Only
Symbol	Name			
AMB (Amb)	Ambient	Ambient Adjustment	-	Input is TC
CALZ (CALZ)	Calibration Zero	Calibration Zero for PV Input (SV Display : PV)	-	
CALS (CAL5)	Calibration Span	Calibration Span for PV Input (SV Display : PV)	-	
RTZ1 (RTZ1)	Retransmission-1 ZERO	Calibration Zero for Retransmission Output-1 (SV Display : If voltage:-0.000 If Current:-4.000)	-	
RTS1 (RTS1)	Retransmission-1 SPAN	Calibration Span for Retransmission Output-1 (SV Display : If voltage:-8.000 If Current:-20.00)	-	
*RTZ2 (RTZ2)	Retransmission-2 ZERO	Calibration Zero for Retransmission Output 2 (SV Display : If voltage:-0.000 If Current:-4.000)	-	

<p>*RTS2 (r t 5 2)</p>	<p>Retransmission-2 SPAN</p>	<p>Calibration Span for Retransmission Output-2 (SV Display : If voltage:-8.000 If Current:-20.00)</p>	<p>-</p>	
-----------------------------------	----------------------------------	--	----------	--

* Not applicable for LC5248E-AT, LC5296V-AT

NOTE:-

- The retransmission output type is jumper selectable. Thus if current type or voltage type output, will be decided by the position of the jumper.
- **The Linear type control output will depend on the type of Retransmission-1 output selection.** If Retransmission-1 type output is 4-20mA, then the linear output will function respectively.
- No need to feed input while calibrating Rx. o/p. just make the value in calibration mode equal to the displayed value.

Example:

1. How to change Input Type

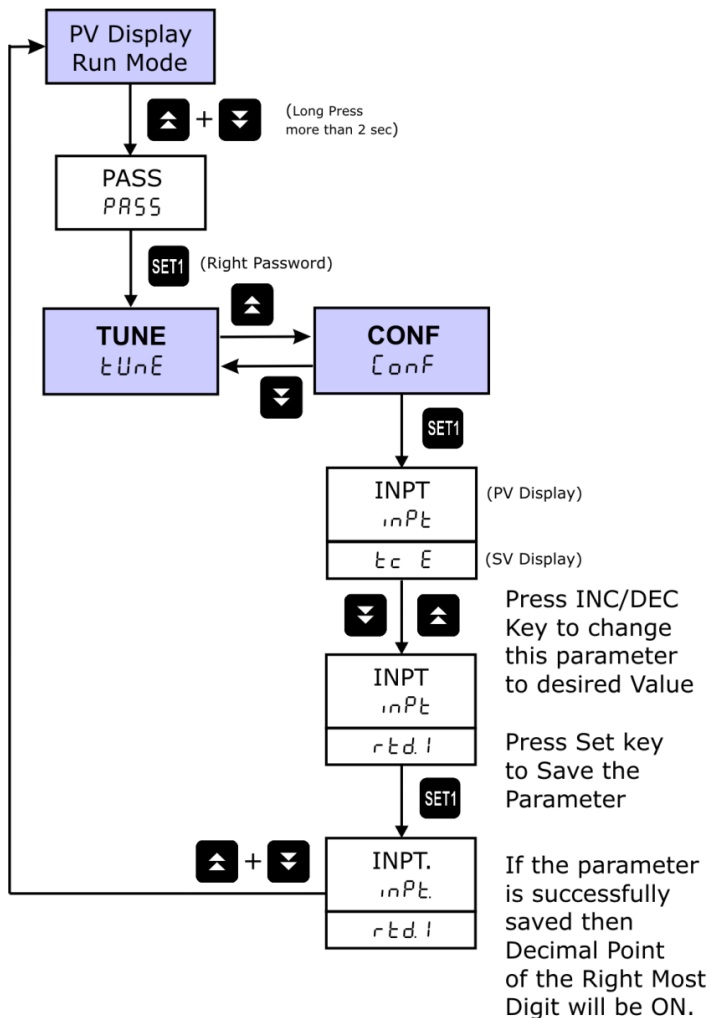

2. How to change Control Set Point-1

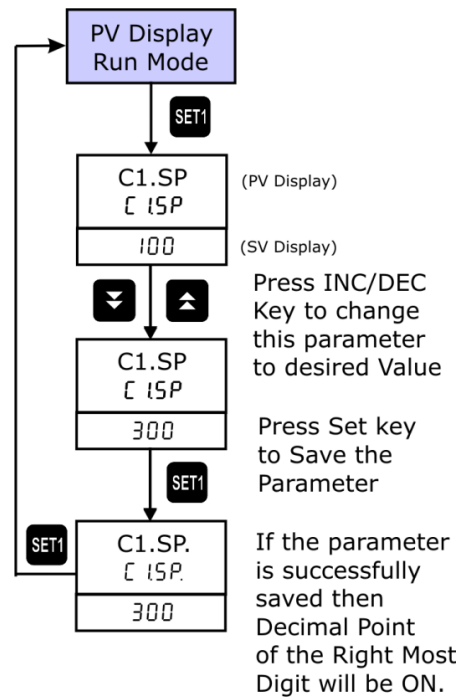

Note:

- Example 2 applies for OT (output type) Relay or SSR. For Linear output, press SET1 key for few seconds for C1.SP to appear in RUN mode.

7. CONTROL FUNCTION

7.1 ON/OFF Control

ON/OFF Controller is the simplest form of temperature control device. The output from the device is either on or off, with no middle state. An on-off controller will switch the output only when the temperature crosses the setpoint. For heating control, the output is on when the temperature is below the set point, and off above set point.

Since the temperature crosses the set point to change the output stage, the process temperature will be cycling continually, going from below set point to above, and back below. In cases where this cycling occurs rapidly, and to prevent contactors and valves from getting damaged, an on-off differential, or "hysteresis," is added to the controller operations. On-Off hysteresis prevents the output from "chattering" or making fast, continual switches if the cycling above and below the set point occurs very rapidly.

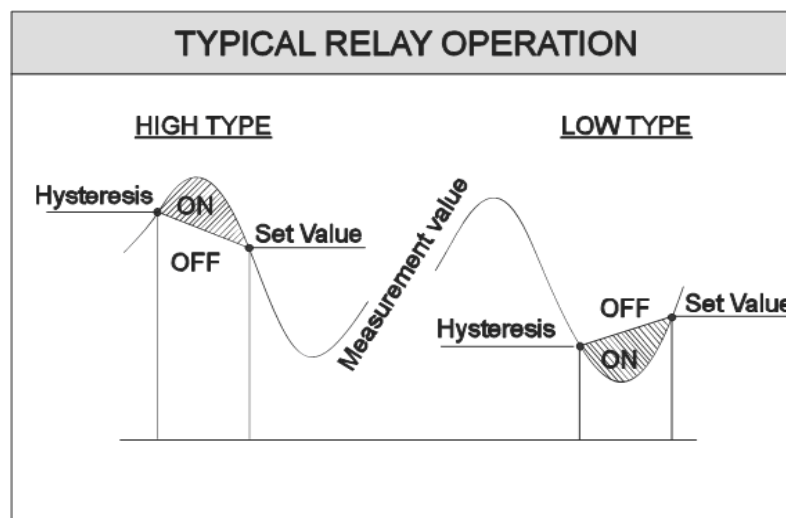

Figure 7.1: Typical Relay operation

High type (H-ON):

For High type of set value, once process value reaches up to set point + Hysteresis value, relay will be ON after few seconds (as per relay delay) and it will be ON until process value goes down to Set point.

Low type (L-ON):

For Low type of set value, once process value reaches down to set point - Hysteresis value relay will be ON after nearly few seconds (as per relay delay) and it will be ON until process value goes up toward Set point.

NOTE:-

- **LC5296-AT/LC5248E-AT /LC5296V-AT has both ON-OFF & PID Controlling for Relay-1. And Relay-2 is used for Alarm output. If ON-OFF controlling is required for Relay-1, COP (Control Type) must be selected as ON-OFF.**
- **When PB, TI, TD term is '0' and auto tune is set 'no', and unit is not in manual mode, then control output will work as on-off controller else it will work as PID controller.**

7.2 PID Control

AUTO TUNE FUNCTION:

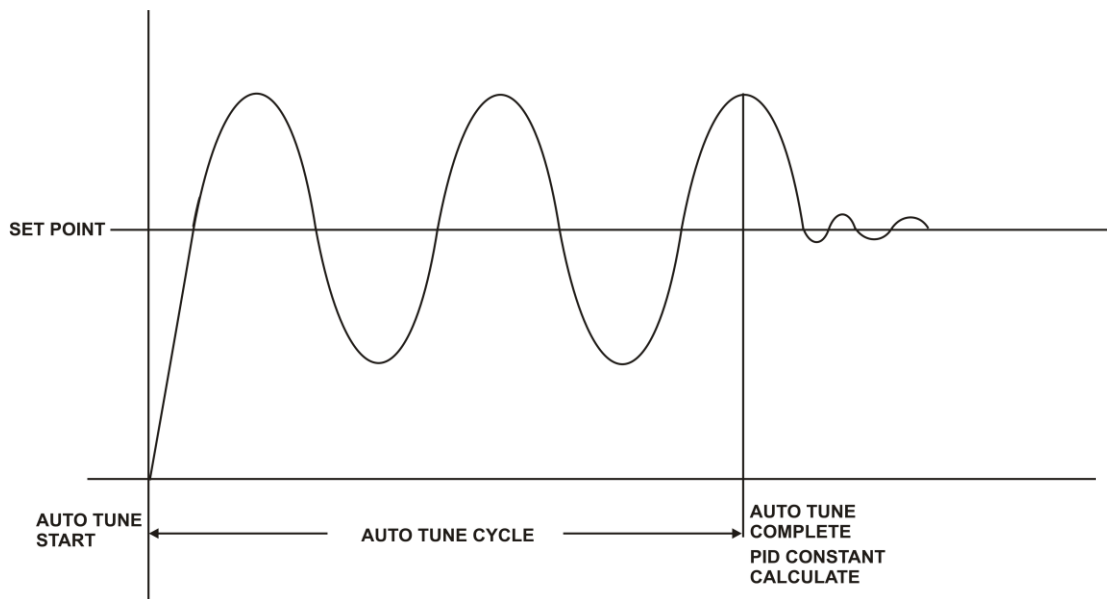

Auto Tuning:

The Auto tuning process is performed at set point. Temperature will oscillate around the set point during tuning process. Set a set point to a lower value if overshooting around the normal process value is likely to cause damage. To start the auto tuning process, set the desired set point, select the parameter A.TUN in TUNE menu and set it to YES.

During Auto tuning lower display (SV) will flash "AT" message.

After auto tune procedure is completed, the message will be removed and controller will revert back to the PID control by using the new calculated PID values. The PID values obtained are stored in the nonvolatile memory.

Control Parameter:-

Proportional BAND:

Proportional action is the action which the control output varies in proportion to the deviation between the setting value and the processing temperature. If the proportional band is narrowed, even if the output changes by a slight variation of the processing temperature, better control results can be obtained as the offset decreases. However, if when the proportional band is narrowed too much, even slight disturbances may cause variation in the processing temperature, and control action changes to ON/OFF action and the so called hunting phenomenon occurs. Therefore, when the processing temperature comes to a balanced position near the setting value and a constant temperature is maintained, the most suitable value is selected by gradually narrowing the proportional band while observing the control results.

Integral Time:

Integral action is used to eliminate offset. When the integral time is shortened, the returning speed to the setting point is quickened. However, the cycle of oscillation is also quickened and the control becomes unstable.

Derivative Time:

Derivative action is used to restore the change in the processing temperature according to the rate of change. It reduces the amplitude of overshoot and undershoots width. If the derivative time is shortened, restoring value becomes small, and if the derivative time is made longer, an excessive returning phenomenon may occur and the control system may be oscillated.

Manual Reset:

Virtually no process requires precisely 50% output on single output controls or 0% output on two output controls. Because of this many older control designs incorporated an adjustment called manual reset (also called offset on some controls). This adjustment allows the user to redefine the output requirement at the set point. A proportioning control without manual reset or Integral time (defined above) will settle out somewhere within the proportioning band but likely not on the set point.

Some controls use manual reset (as a digital user programmable value), this allows the user to preprogram the approximate output requirement at the set point to allow for quicker settling at set point when Automatic reset (Integral time) set to zero. Range for the manual reset is -50.0% to +50.0% of proportional band for LC5296-AT.

Cycle Time:

The Cycle time for output is the time where the output is on for percentage of that time and off for a percentage of that time, creating a portioning effect. The cycle time is only used where PI, PD or PID control action is used. The shorter the cycle time, the higher the proportionate resolution is, and better is the control.

For Relay output: Set to 10 to 300 seconds or more

For SSR output: Set to 1 to 60 seconds or more

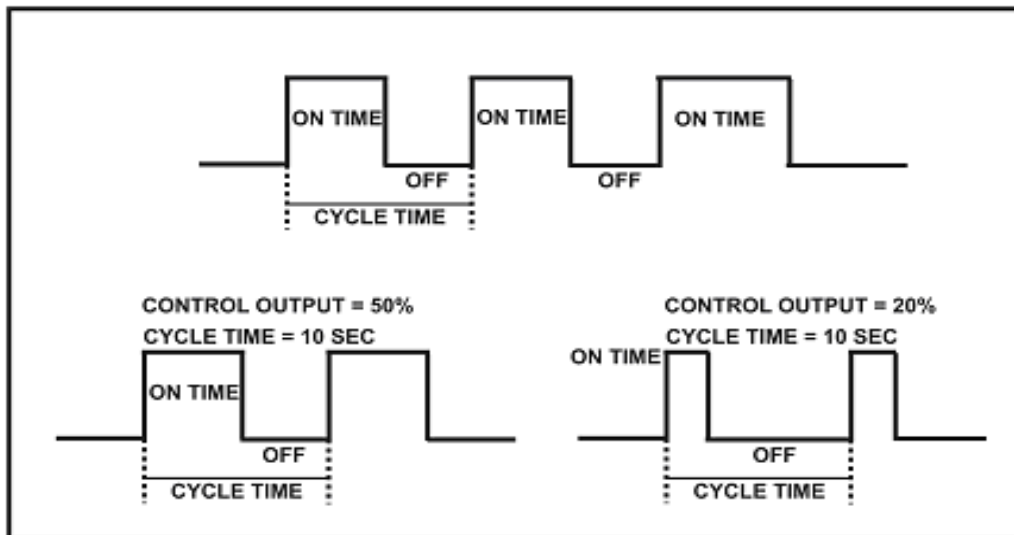

BASIC PID TUNING PROCEDURE:

ADJUSTMENT SEQUENCE	SYMPTOM	SOLUTION
Proportional Band	Slow Response	Decrease PB
	Overshoot or Oscillation	Increase PB
Integral Time	Slow Response	Decrease TI
	Instability or Oscillation	Increase TI
Derivative Time	Slow Response or Oscillation	Decrease TD
	High Overshoot or Instability	Increase TD

P ACTION: -

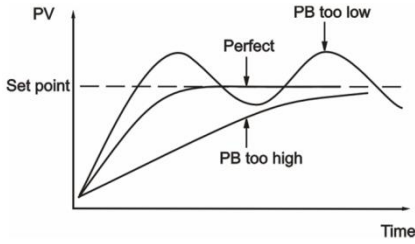

I Action: -

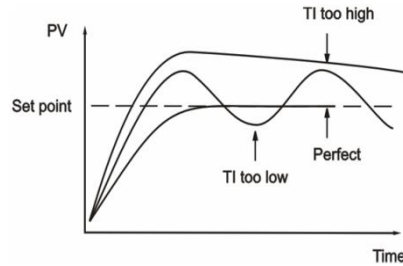

D Action: -

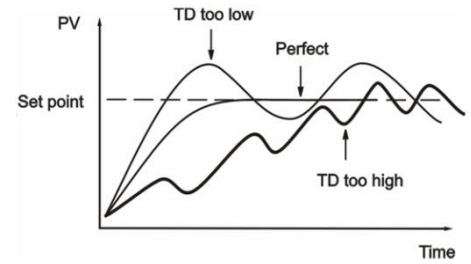

Control output Selection:

"COP"	"OT"	Terminal 2,3,4	Terminal 5,6,7	Terminal 17, 18	Terminal 19, 20
P/PI/PID	Relay	USE FOR CONTROL ACTION	ALARM2	AO output	AO Output/ Communication
	SSR	USE FOR CONTROL ACTION	ALARM2	AO output	AO Output/ Communication
	Linear	ALARM1	ALARM2	USE FOR CONTROL ACTION	AO Output/ Communication
	VPFN	Forward Relay	Revers Relay	AO output	AO Output/ Communication
ON-OFF Action	Relay	USE FOR CONTROL ON-OFF ACTION	ALARM2	AO output	AO Output/ Communication

NOTE:-At a time either Relay or SSR is provided (factory set)
 For Terminal 19, 20 only one type of output is available.
 (AO Output or Communication)(Factory Settable)

7.3 Ramp and Soak Function

This function is used to stop the sudden change of set point. The ramp function is performed in following conditions. The target set point is changed. Target set point number is changed. **(For example:** Switching from SP-1 to SP-2). The power is turned ON or the controller is recovered from power failure. A change is made from manual mode to auto mode.

When the process value crosses the set point value for the first instant, a "soak period" begins.

The ramp function will be performed when ramp unit parameter is selected as $\bar{n} \text{ Inr}$ (minute rate) or Hrr (hour rate). The ramp parameter $r \bar{n} P . r$.

The Soak rate is programmed by setting $SoP . r$. Soak time will be performed according to $S . hod$ and $S . r5t$. When the soak type is $S . hod$ it will not reset the soak rate when the power is down and when the Soak type is $S . r5t$ it will reset the soak rate when the power is down.

The ramp and Soak function will be cancelled in following conditions.

- A change is made from Auto mode to manual mode.
- Sensor Failure occurs.
- Auto tuning function is activated.

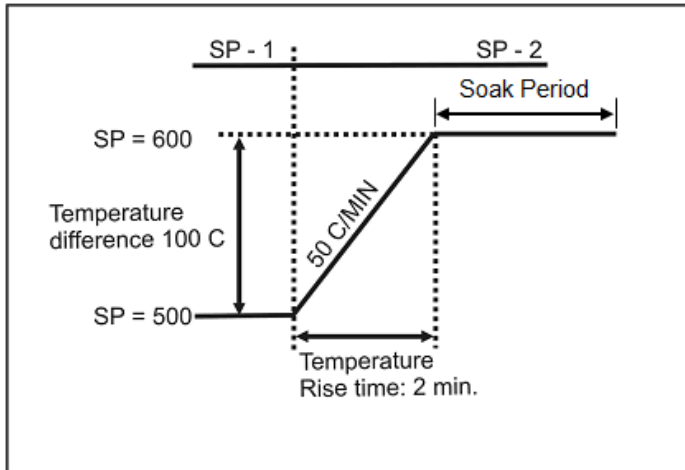

7.4 Motor Position Control without slide wire feedback:

In Motor Position Control without slide wire feedback control, user has to set the operating time required for a valve to change from the fully closed position to the fully open position. With the preset operating time, the controller controls the valve by estimating the position. There is no need for feedback input wiring.

When in manual operation you can directly manipulate the controller's output terminals. Pressing Increment key sends the valve into opening motion while pressing the Decrement key sends it to closing motion.

The figure below shows a schematic representation of Motor Position Control without slide wire feedback control.

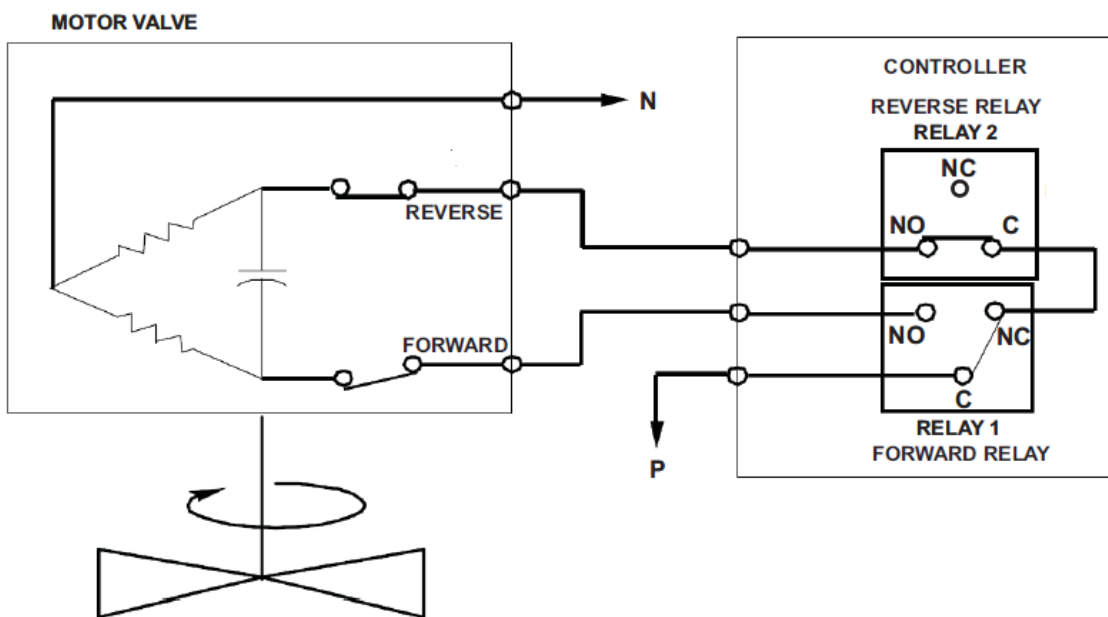

8. ALARM OUTPUT

For all Alarm outputs there are five settings. (As shown in configuration mode Menu)

- Set Value (in run mode)
- Type
- Hysteresis(Dead band)
- Direction (Normal/Fail safe)
- Delay

SET VALUE: Alarm set point

8.1 ALARM TYPES

Various alarm operations are shown in the reference figure.

ALARM TYPE NO	Display message	ALARM TYPE	Note
0	<i>nonE</i>	None	NO operation available
1	<i>P_{ud}H</i>	Deviation High alarm	Ref figure 3
2	<i>P_{ud}L</i>	Deviation Low alarm	Ref figure 4
3	<i>P_{ud}r</i>	Deviation High & Low range alarm	Ref figure 5
4	<i>P_{ud}b</i>	Deviation High & Low Band alarm	Ref figure 6
5	<i>P_uRH</i>	Absolute value High alarm	Ref figure 1
6	<i>P_uRL</i>	Absolute value Low alarm	Ref figure 2
7	<i>SPRH</i>	Absolute value set point high alarm	Ref figure 7
8	<i>SPRL</i>	Absolute value set point low alarm	Ref figure 8
9	<i>P_SdH</i>	Deviation High alarm with standby	Same as figure 3
10	<i>P_SdL</i>	Deviation Low alarm with standby	Same as figure 4
11	<i>P_Sd_r</i>	Deviation High & Low range alarm with standby	Same as figure 5
12	<i>P_Sd_b</i>	Deviation High & Low limit alarm with standby	Same as figure 6
13	<i>P_SRH</i>	Absolute value High alarm with standby	Same as figure 1
14	<i>P_SRL</i>	Absolute value Low alarm with standby	Same as figure 2
15	<i>P_u-E</i>	PV error(OPEN/OVER/UNDER)	Note 1

NOTE-1:

The fault diagnosis output turns on in case of input burnout (PV) failure.

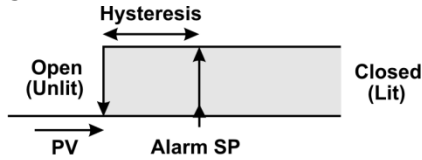

Absolute Value High Alarm

Figure: 1

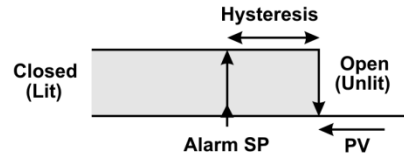

Absolute Value Low Alarm

Figure: 2

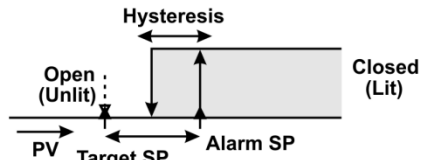

Deviation High Alarm

Figure: 3

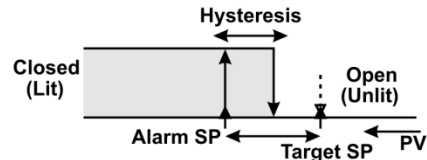

Deviation Low Alarm

Figure: 4

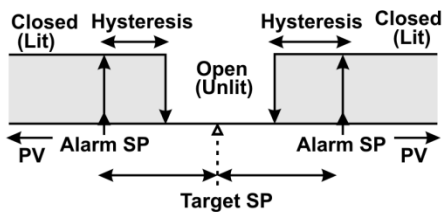

Deviation High/Low Range Alarm

Figure: 5

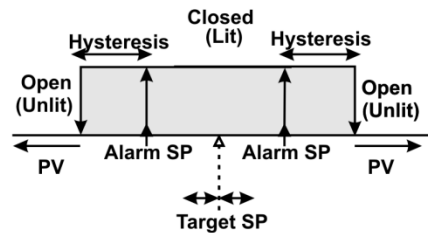

Deviation High/Low Band Alarm

Figure: 6

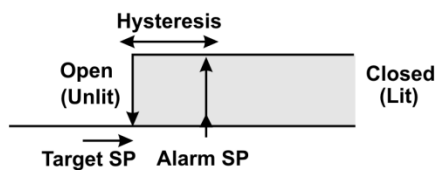

Absolute Value Set Point High Alarm

Figure: 7

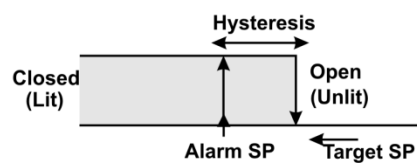

Absolute Value Set Point Low Alarm

Figure: 8

NOTE:-

- LIT = LED on, UNLIT = LED off
- Up arrow indicate Alarm will ON from this value.
- Down arrow indicate Alarm will OFF from this value.

Hysteresis (Dead band): Hysteresis (Dead band) application is shown in the figure.

Direction:

All the figures here are shown considering the setting is direct (Normal). If the settings are reversing (Fail Safe), the relays will behave exactly the opposite. However, it's worth mentioning that the relays will be in off (de-energized state on Power on / reset condition). They will energize only after approximate 5 seconds. When alarm type none is selected, ALRAM relay status depends on Direction.

Delay:

A time delay can be provided for the actual output. The relay will operate after the set delay time.

Standby operation:

For alarm types, 9 to 14, the relay action happens only after the PV has crossed the SP after power on.

Example:-

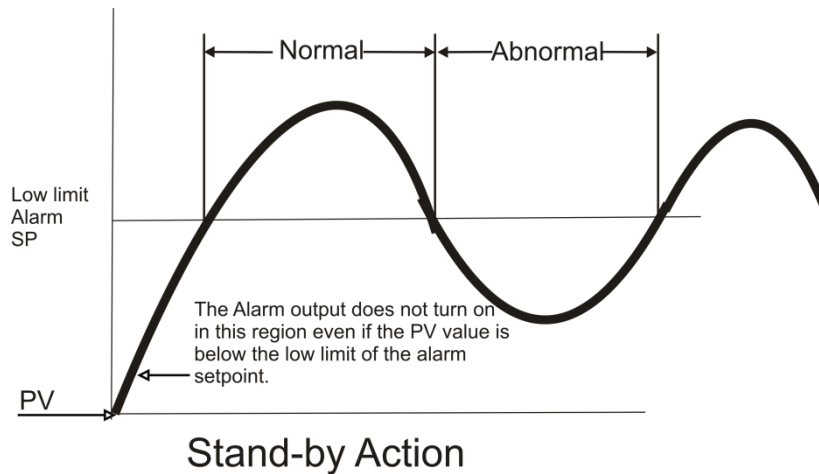

FIGURE 8.1. ALARM OUTPUT DIAGRAM

9. CALIBRATION PROCEDURE

9.1 Procedure for CAL-zero and CAL-span

The instrument is factory calibrated for the specified range, but due to long term drift of components, re-calibration may be necessary in some cases. For calibrating the instrument a reliable source is required. This source should be at least ten times accurate compared to the range of the instrument.

The unit can be calibrated without opening it and without trim pots.

For Entering into the Calibration Mode, Please refer Menu Layout.

After applying appropriate Input from the calibrator source, press 'INCREMENT' OR 'DECREMENT KEY' to bring the actual process value on display.

Example:-

At zero calibration reading expected on the display is 100 and it shows 107, adjust the process value to 100 by using 'DECREMENT KEY'. Now press 'SET' to store the calibration parameter in non-volatile memory. Similarly one can calibrate Ambient, SPAN and retransmission parameters.

For calibrating i/p, both zero and span are calibrated. Here **one-shot calibration** technique is used, i.e. the zero and span are calibrated once. Individual zero or span can also be calibrated; first calibrate zero and then span. While calibrating thermocouple type input, first calibrate the ambient (if required) and then continue with the span calibration of the same.

9.2 Procedure for RET-zero and RET-span

For calibrating the retransmission output, both retransmission zero and retransmission span has to be calibrated. At a time there can be either one or two retransmission output available. If only one retransmission is used, then calibrate **RTZ1** (retransmission 1 zero) and **RTS1** (retransmission 1 span) and if there are two retransmission outputs available, then calibrate **RTZ2** (retransmission 2 zero) and **RTS2** (retransmission 2 span) for second retransmission. No need to feed input while calibrating retransmission o/p. it is like calibrating using digital trim pot. Only look at the output, display value has no significance with output generated.

Example:-

At retransmission zero calibration, expected output is 4.00mA and it gives 4.153mA. Then adjust the output value to 4.153 by using 'INCREMENT KEY'. Now press 'SET1' to store the calibration parameter in non-volatile memory. Similarly one can calibrate retransmission span.

10. COMMUNICATION PROTOCOL–MODBUS RTU

10.1 Introduction

The unit can be connected in RS-485 communication data link either in multi drop or repeat mode. Each unit must have unique Serial Number. Entire range of addresses (1 to 247) may be used. Before starting any communication, choose a baud rate compatible to the host computer. The serial protocol used is MODBUS RTU.

Function Code for Modbus

CODE	NAME	Function
01	Read coil status	Use to read Relay and Digital output status
03	Read Holding registers	Use to read PV, Control, RSP output etc
04	Read input registers	Use to read programmable registers
06	Preset Single register	Use to write programmable register

The error checking field contains a 16-bit value implemented as two eight-bit bytes. The error check value is the result of a Cyclical Redundancy Check (CRC) calculation performed on the message contents.

10.2 Parameter Address Details

Sr. No.	Parameters	Absolute Address	Type	Access Type
1	PROCESS VALUE	30001	Int	Read Only
2	POWER IN PERCENTAGE	30002	Int	Read Only
3	AUTOTUNE STATUS	30003	Int	Read Only
4	AMBIENT	30004	Int	Read Only
5	SSR STATUS	30005	Int	Read Only
6	RELAY-1 STATUS	30006	Int	Read Only
7	RELAY-2 STATUS	30007	Int	Read Only

NOTE: Process Value (PV) Error Conditions Value

OPEN : 32767
 UNDER : 32765
 OVER : 32766

Sr. No.	Parameters	Absolute Address	Type	Access Type
1	Input Type	40001	Int	R + W
2	Zero	40002	Int	R + W
3	Span	40003	Int	R + W
4	Filter	40004	Int	R + W
5	SET Type-1	40005	Int	R + W
6	Open Sensor Status	40006	Int	R + W
7	Relay Delay -1	40007	Int	R + W
8	Hysteresis 1	40008	Int	R + W

9	Decimal Point	40009	Int	R + W
10	Display set point	40010	Int	R + W
11	Brightness	40011	Int	R + W
12	Serial Number	40012	Int	R + W
13	Baud Rate	40013	Int	R + W
14	Retransmission o/p Type -1	40014	Int	R + W
15	Retransmission o/p direction - 1	40015	Int	R + W
16	Retransmission o/p Type -2	40016	Int	R + W
17	Retransmission o/p direction - 2	40017	Int	R + W
18	Control output type	40018	Int	R + W
19	Control type	40019	Int	R + W
20	Set Value 1	40020	Int	R + W
21	Set Value 2	40021	Int	R + W
22	Alarm-1 Type	40022	Int	R + W
23	Alarm- 2 Type	40023	Int	R + W
24	Alarm-1 hysteresis	40024	Int	R + W
25	Alarm-2 hysteresis	40025	Int	R + W
26	Alarm-1 logic	40026	Int	R + W
27	Alarm-2 logic	40027	Int	R + W
28	Alarm-1 delay	40028	Int	R + W
29	Alarm-2 delay	40029	Int	R + W
30	Auto CJC	40030	Int	R + W
31	Fixed CJC	40031	Int	R + W
32	Pass word	40032	Int	R + W
33	Version	40033	Int	R
34	Proportional band	40034	Int	R + W
35	Integral time	40035	Int	R + W
36	Derivative time	40036	Int	R + W
37	Cycle time	40037	Int	R + W
38	Manual reset	40038	Int	R + W
39	Sampling rate	40039	Int	R + W
40	Sampling period	40040	Int	R + W
41	Control set point	40041	Int	R + W
42	Control Output Low Limit	40042	Int	R + W
43	Control Output High Limit	40043	Int	R + W
44	Auto/Manual	40044	Int	R + W
45	% POWER	40045	Int	R + W
46	Ramp - type	40046	Int	R + W
47	Ramp - rate	40047	Int	R + W
48	Soak - rate	40048	Int	R + W
49	Soak type	40049	Int	R + W
50	offset	40050	Int	R + W
51	Function Key	40051	Int	R + W
52	Motor Travel time	40052	Int	R + W
53	Dead Band	40053	Int	R + W

10.3 Exceptional Response

TABLE- 8

CODE	MEANING
01	Function code Invalid. It must be 01, 05, 03 or 06.The function code received in the query is not allowable action for the slave.
02	Illegal address value. The data address received in the query is not an allowable address for the slave.
03	Illegal data value. A value contained in the query data field is not an allowable value for the slave.
06	When Master device write some parameters to Slave device, If slave device busy then it will send 06 code to indicate slave device is busy.

Note:

1. Refer Menu Mode Description Table the value & Range of each Parameter.

EX: Input Type (Applicable Range: 0 to 11):

Input Type	Value
E-tc	0
J-tc	1
K-tc	2
T-tc	3
B-tc	4
R-tc	5
S-tc	6
RTD 0.1 degree	7
RTD 1 degree	8
0 - 5V	9
1 - 5V	10
0 - 10V	11

11. APPENDIX

11.1 Troubleshooting

If the operating display does not appear after turning on the controller's power, follow the measures in the procedure below.

If a problem appears complicated, contact our sales representative.

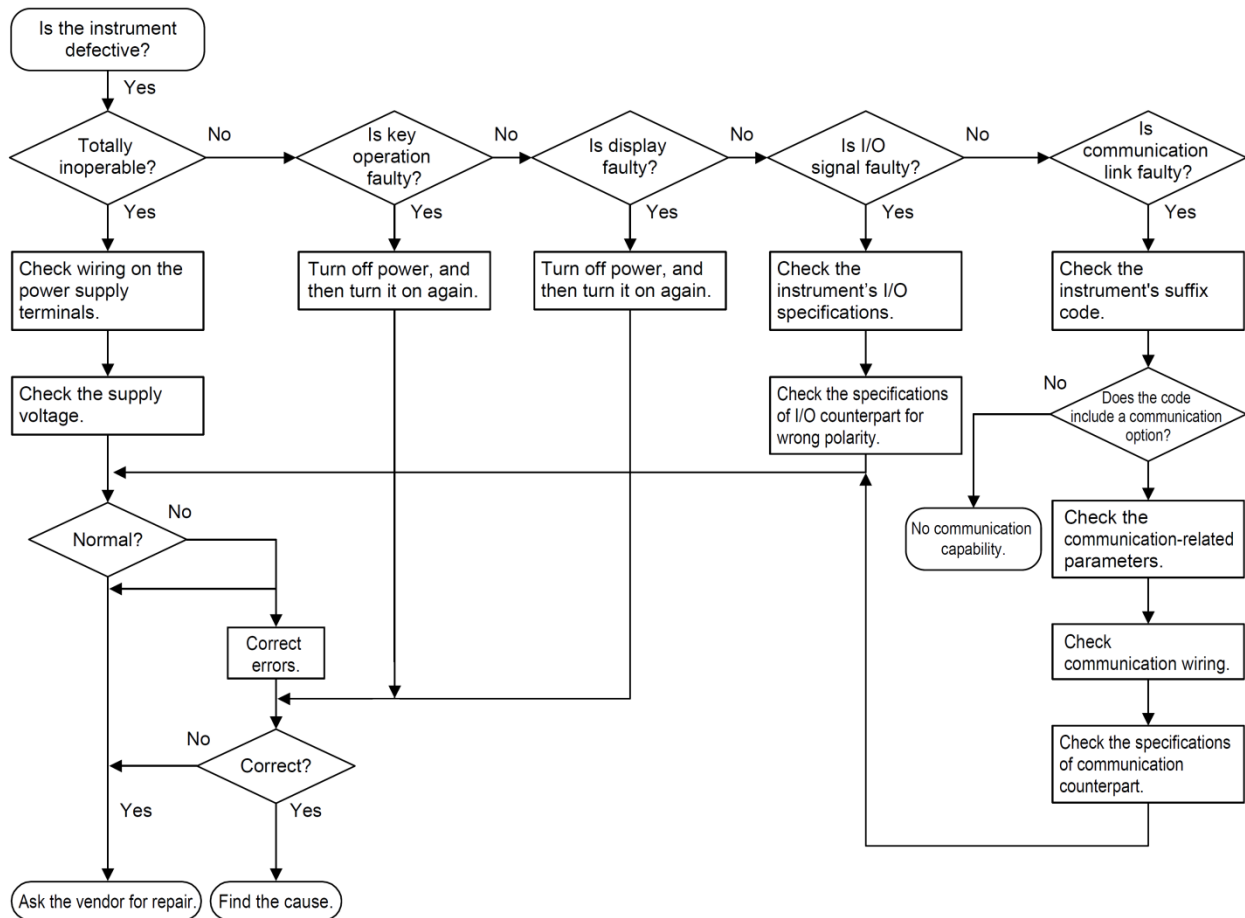

IMPORTANT



Take note of the parameter settings when asking the vendor for repair.

11.2 ON-OFF LOGIC

Relay type	PV	Relay	LED
Hi-On	PV > SP	On	On
	PV < SP	Off	Off
Open sensor	Up scale	On	On
	Down scale	Off	Off
Low-On	PV > SP	Off	Off
	PV < SP	On	On
Open sensor	Up scale	Off	Off
	Down scale	On	On

11.3 Retransmission Output Table for OPEN /OVER /UNDER Condition

RETRASMISSION	VARIABLE	SCALE	ACTION	OPEN	OVER	UNDER
4-20mA	PV	UP	DIR	20.8	20.8	3.2
	PV	DOWN	REV	3.2	3.2	20.8
	PV	UP	REV	20.8	3.2	20.8
	PV	DOWN	DIR	3.2	20.8	3.2
1-5V	PV	UP	DIR	5.2V	5.2V	0.8V
	PV	DOWN	REV	0.8V	0.8V	5.2V
	PV	UP	REV	5.2V	0.8V	5.2V
	PV	DOWN	DIR	0.8V	5.2V	0.8V
	PV	DOWN	DIR	0.8V	5.2V	0.8V

NOTE: -

1. OPEN/UNDER/OVER condition is applicable to all input types except 0-5v / 0-20mA.

11.4 Linear Output Table for OPEN/OVER/ UNDER Condition

CONTROL OP	Process Scale	Output Direction (O.DIR)	DISPLAY INDICATION		
			OPEN	OVER	UNDER
4-20mamp Current	UP	DIR	20.0	20.0	4.0
	DOWN	REV	4.0	4.0	20.0
	UP	REV	20.0	4.0	20.0
	DOWN	DIR	4.0	20.0	4.0
SSR Pulse Output	UP	DIR	ON	ON	OFF

	DOWN	REV	OFF	OFF	ON
	UP	REV	ON	OFF	ON
	DOWN	DIR	OFF	ON	OFF
RELAY	UP	DIR	ON	ON	OFF
	DOWN	REV	OFF	OFF	ON
	UP	REV	ON	OFF	ON
	DOWN	DIR	OFF	ON	OFF

11.5 Jumper Settings for Addon Card Selection & Retransmission Output Type



Applicable for LC5296-AT

- LC5296-AT comes with different Variants differing by various Output option available.
- There are Two Addon Card Slots available on PCB of Signal Card. The Right Most Slot is fixed for Retransmission (Analog) Output. And the other Left Slot can be used for either Retransmission or RS-485 Communication Card by appropriate Jumper setting shown in below figure.
- 0E (SMD 0805) Resistor is used for shorting the Jumper.
- There are mainly Two types of Retransmission Output is available:
- Voltage (0-10VDC, 0-5VDC, 1-5VDC)
- Current (4-20mADC, 0-20mADC)
- This can be Settable by changing the Position of Shorting Link Jumpers on Retransmission Addon Card shown in below figure.
- **Jumper Setting for Retransmission card: m61Cao201**

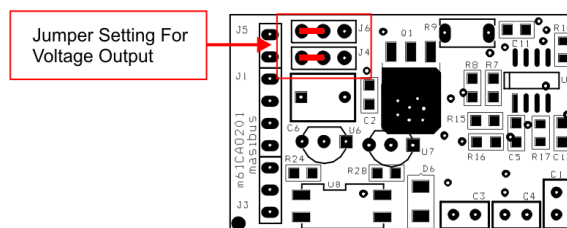
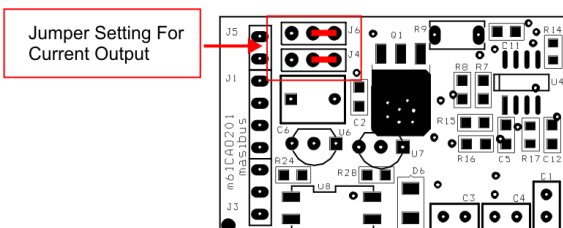
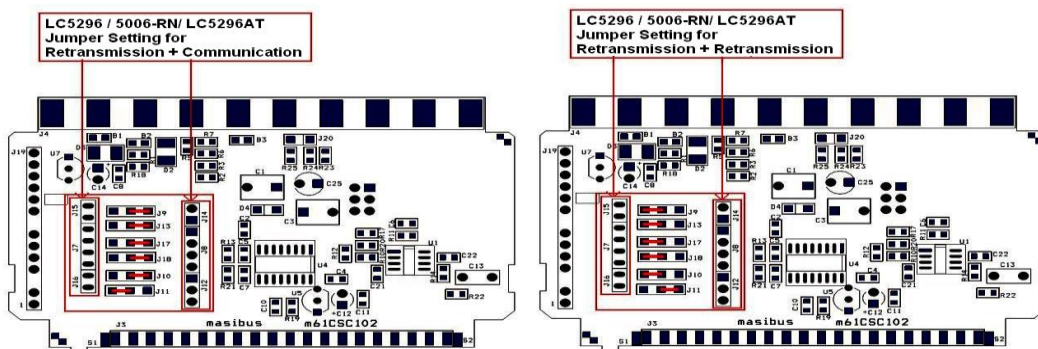

- **Jumper Setting for Retransmission card: m61Cao102**

Jumper Settings for Current Output

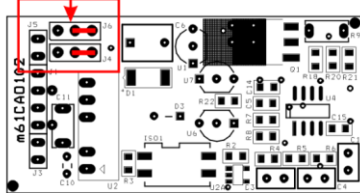

Jumper Settings for Voltage Output

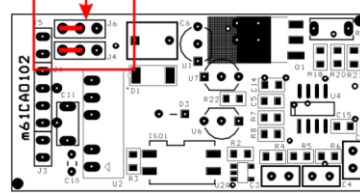

Applicable for LC5248E-AT

LC5248E-AT
Jumper setting for Communication

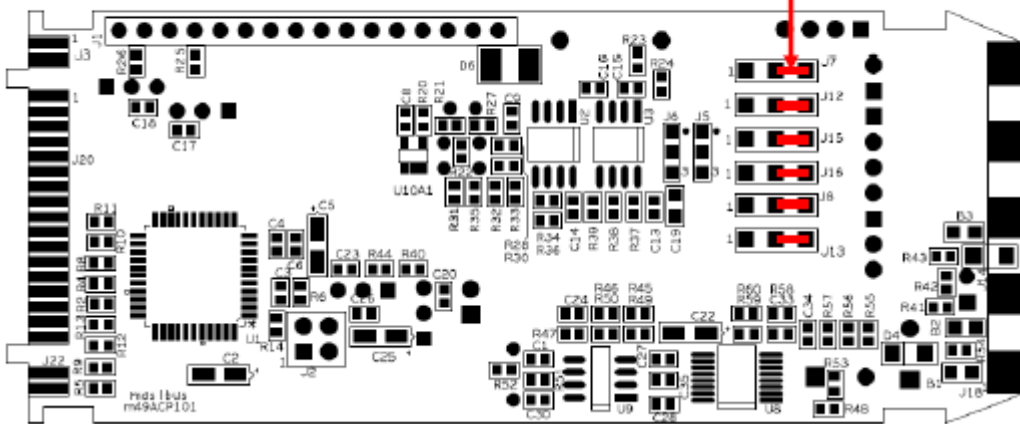

- **Jumper Setting for Retransmission card: m49Acp101**

Current Output

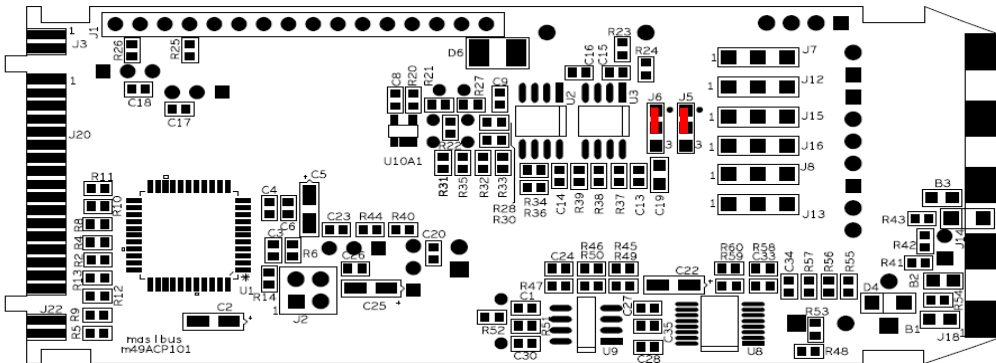

Voltage Output

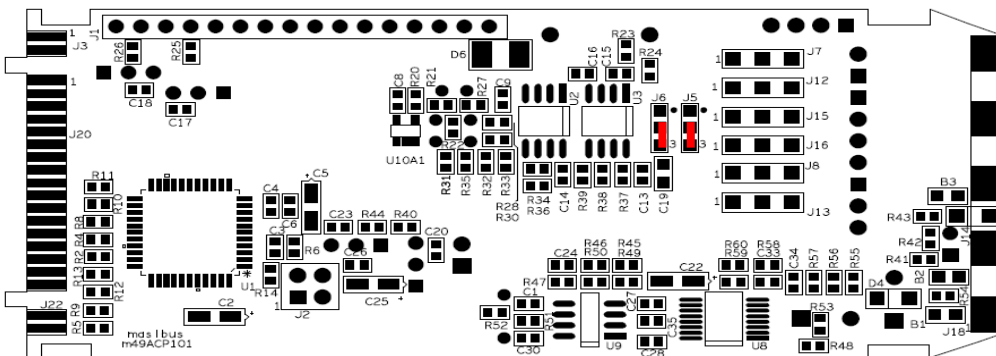

**LC5296V-AT
Jumper Setting for
Communication + Retransmission**

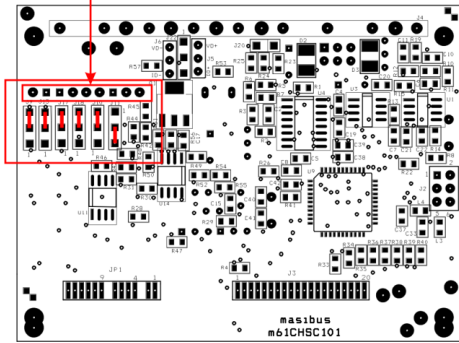

**LC5296V-AT
Jumper Setting for
Retransmission + Retransmission**

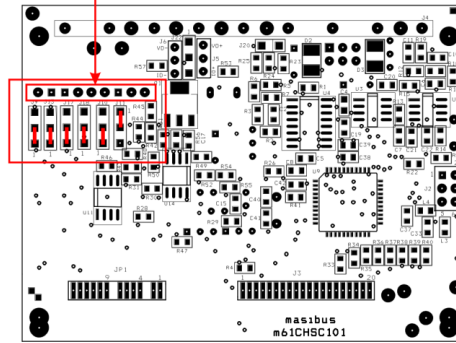

11.6 Load connection

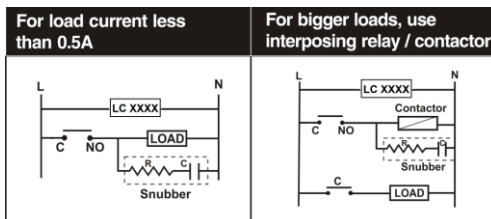

Electrical precautions during use

Electrical noise generated by switching of inductive loads can create momentary disruption, erratic display, and latch up, data loss or permanent damage to the instrument. Use of snubber circuits across loads as shown above, is recommended.