



AUTO TUNE PID CONTROLLER

SPECIFICATION

Input type	Temp. Range °C	Input type	Temp. Range °C
PT100 (0.1°C)	-199.9 to 850.0	B	450 to 1800
PT100	-200 to 850	R	0 to 1768
E	-200 to 1000	S	0 to 1768
J	-200 to 1200	*4-20mA / 1-5VDC	-1999 to 9999 (Field Scalable)
K	-200 to 1372	0-20mA / 0-5VDC	
T	-200 to 400	*0-10VDC	

*Use external 250ohms, 0.1% for current Input
Table-1.1

INPUT

Accuracy T/C and RTD: Linear :	± 0.25% of FS ± 1 count ± 0.1% of Full Span ± 1 count
Resolution	ADC:16 bits,Display :0.1°C / 1 Count
Sampling Rate	4 Samples/Sec
CJC Error	±3.0 °C Max
Sensor Burnout current	0.25uA
RTD excitation current	0.166mA (Approx)
Allowable wiring resistance for RTD	Maximum 15 ohms/wire (Resistance between three wires should be equal)
NMRR	> 40 dB
CMRR	> 120 dB
Temp-co	< 100ppm/°C
Input Impedance	> 1MΩ (Voltage Input), 250Ω (Current Input)
Max Voltage	20VDC

DISPLAY

PV Display	4-Digit, 7-Segment, 0.40" High, Red
SV Display	4-Digit, 7-Segment, 0.31" High, Green
Status Indication	Individual RED Led's for Relay/SSR Status
Keys	Enter, Auto Manual, Increase, Decrease

OUTPUT TYPE

Relay output	
No. Of output	Relay-1: For PID or ON-OFF Controlling. • Used as Alarm-1 Output if Output Type is SSR Relay-2 :Alarm-2 Output
Type	Single Change over, Two Terminals (C,NO)
Rating	5A @ 230VAC / 30VDC

SSR output

Output signal	On/off condition 11VDC or more /2VDC or less
Resolution	10 ms

POWER SUPPLY

Standard	85-265VAC/ 100-300VDC
Optional	18-36VDC
Power consumption	<5 VA

ENVIRONMENTAL CONDITION

Humidity(Non-Condensing)	30% to 95% RH
Instrument Warm-up Time	Approx. 15 minutes
Ambient Temperature	0 to 55°C
Storage Temperature	0 to 80°C

PHYSICAL

Front Bezel	48 x 48 mm
Panel Cutout	45 x 45 mm
Depth Behind The Panel	77mm
Weight (Approx.)	120g
Enclosure Material	ABS
Enclosure Protection	IP20
Terminal Cable Size	2.5 mm ²

ORDERING CODE

Model	Input	Power Supply	Output
LC5248L-AT	1 E	U1 85-265VAC /100-300VDC	1 RL1+RL2
	2 J		2 SSR+RL1
	3 K		3 SSR+RL1 + RL2
	4 T		
	5 B	U2 18-36VDC	
	6 R		
	7 S		
	9 PT-100		
	C 1 to 5V		
	D 0 to 5V		
	E 4-20mA		
	F 0-20mA		
	G 0to10V		

MOUNTING DETAILS

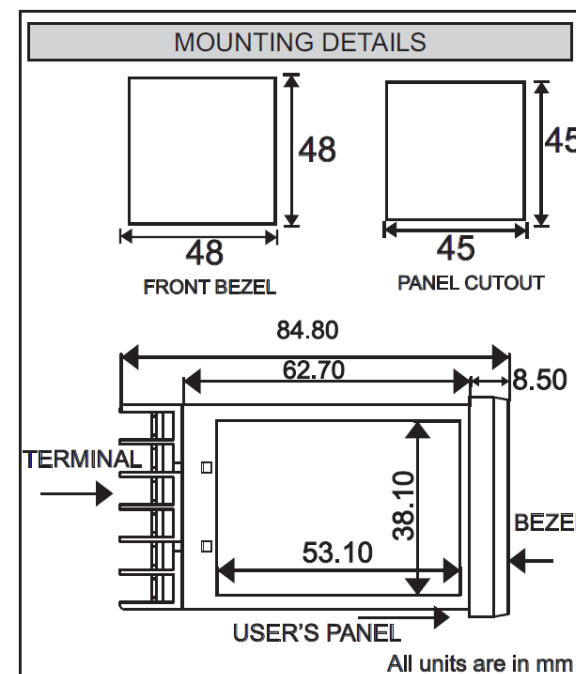

TERMINAL CONNECTION

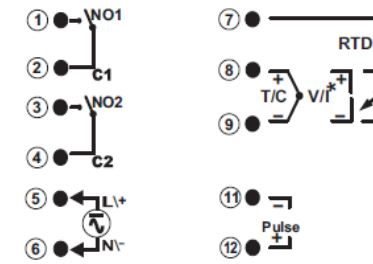

LOAD CONNECTION

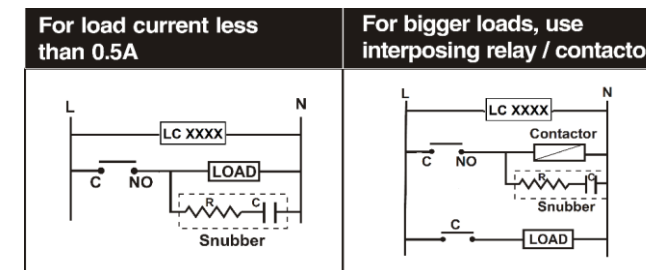

Electrical precautions during use: Electrical noise generated by switching of inductive loads can create momentary disruption, erratic display, latch up, data loss or permanent damage to the instrument. Use of snubber circuits across loads as shown above, is recommended.

SAFETY/WARNING PRECAUTIONS

To ensure that the device can be operated safely and all functions can be used, please read these instructions carefully. Installation and Start-up must be carried out by qualified personnel only. The relevant county-specific regulations must also be observed. Before start-up it is particularly important to ensure:
• Terminal wiring: check that all cables are correctly connected according to the connection diagram
• All wiring must confirm to appropriate standards of good practice and local codes and regulations. Wiring must be suitable for voltage, current and temperature rating of the system.
• Unused control terminals should not be used as jumper points as they may be internally connected, which may cause damage to the unit.

WARRANTY

Warranty does not apply to defects resulting from action of the user such as misuse, improper wiring, operation outside of specification, improper maintenance or repair, or unauthorized modification. Masibus is not liable for special, indirect or consequential damages or for loss of profit or for expenses sustained as a result of a device malfunction, incorrect application or adjustment Masibus' total liability is limited to repair or replacement of the product. The warranty set forth above is inclusive and no other warranty, whether written or oral, is expressed or implied.

PARAMETER SETTINGS

Following parameters can view or change during run time. Press **Enter** key to show percentage power (0.0 to 100.0%).
• For Thermocouple input type, Press **Up** key to show ambient temperature
• During manual mode, **Down** and **Up** key will use to modify the percentage power.

- Function of **A/M** key is decided by parameter selection in F.Key. If A-M, Press **A/M** to toggle between AUTO & MANUAL mode. If r-S, Press **A/M** to toggle between RUN & STOP the controlling action.
- 99.9 shows on lower display indicates 99.9% output power in manual mode.
- Following parameters can view using **Enter** and change using **Down** or **Up** Keys.

Display	Name	Description	Default Value	Shows only if
C1.SP (C1.sp)	Control Set Point 1	Range Depending on PV sensor type selected	100	-
A1.SP (A1.SP)	Alarm Set Point 1		100	Output Type is SSR
A2.SP (A2.SP)	Alarm Set Point 2		100	-

Press **Down** and **Up** keys simultaneously will ask to enter password. On entering correct pass word, unit will show mode. **Enter Conf Ctrl** mode.

Enter Mode

NOTE: This Menu appear for COP (Control Output Type) other than ONOF (ON-OFF)

A.TUN (A.tun)	Auto Tune	Auto Tuning Process yes / no	NO	COP is PI or PID
PB (Pb)	Proportional Band	0 to 9999 or 0.0 to 999.9	10.0	COP is P or PI or PID
TI (t.i)	Integral Time	0 to 1000	60	COP is PI or PID
TD (t.d)	Derivative Time	0 to 180	0	COP is PID
CT (t.t)	Cycle Time	SSR o/p: 1 - 60 sec Relay o/p: 10 - 300 sec	10	
O.DIR (o.dir)	Output Direction	Reverse/Dir ect	0 (REV)	COP is P or PI or PID
MR (m.r)	Manual Reset	To shift PB and for critical Controlling situations. -(PB/2) to +(PB/2)	0	COP is P

Conf Mode

INPT (inp.t)	INPUT Type	As per table 1.1	TC E	
ZERO (z.e.r.o)	Zero	Any value within the Input Range & less the SPAN Value.	-200	If TC E
SPAN (s.p.a.n)	Span	Any value within the Input Range & greater the ZERO Value.	1000	If TC E
DP (d.p)	Decimal Point	0/ 0.0/ 0.00/	0	Input Type

		0.000		is Linear
*FLTR (FLTR)	Filter	Enable or Disable Filter for PV Input(0 to 6)	3	
OFST (OFST)	Offset	Offset to be added in PV value -1000 to 1000	0	
TSP1 (TSP1)	Type of Set Point	L-ON / H-ON Lower ON Higher ON	L-ON	COP is ON-OFF.
OPES (OPES)	OPEN Sensor Status	Set Control O/P when Input OPEN condition. DOWN /UP	UP	
RD1 (RD1)	Relay Delay	For Relay-1 1 to 99 sec	1 sec	COP is ON-OFF.
HY-1 (HY-1)	Hysteresis	Hysteresis Value (in °C) for Relay-1	1	COP is ON-OFF.
DISP (DISP)	Display Set Point	Set Point to show in SV display in RUN mode while device is in Auto Mode C1.SP / R2.SP / R1.SP	C1.sp	Output Type is SSR then A1.SP will appear.
BRHT (BRHT)	Brightness	10 to 100	100	
OT (OT)	Output Type	Output Type RELAY / SSR (Factory Settable)	Relay	
COP (COP)	Control Output Type	P / P1 / Pid / autoF	PID Type	ON-OFF option will not appear if OT is SSR
CO.LO (CO.LO)	Control Output Low Limit	0.0 to 100.0%	0.0	
CO.HI (CO.HI)	Control Output High Limit in %	0.0 to 100.0%	100.0	
A1TP (A1TP)	Alarm Type - 1	Refer ALARM Type 0 to 15	Pv.A.L	Output Type is SSR
A2TP (A2TP)	Alarm Type - 2	Refer ALARM Type 0 to 15	Pv.A.L	
A1HY (A1HY)	Alarm 1 Hysteresis	Set Hysteresis for Alarm-1	1	Output Type is SSR
A2HY (A2HY)	Alarm 2 Hysteresis	Set Hysteresis for Alarm-2	1	

A1LC (A1LC)	Alarm 1 Logic	Set Logic for Alarm-1 nor \bar{n} / FL5F**	Normal	Output Type is SSR
A2LC (A2LC)	Alarm 2 Logic	Set Logic for Alarm-2 nor \bar{n} / FL5F**	Normal	
A1DY (A1DY)	Alarm 1 Delay	1 to 99 sec	1	Output Type is SSR
A2DY (A2DY)	Alarm 2 Delay	1 to 99 sec	1	
A.CJC (A.CJC)	Auto Cold Junction Compensation	NO / YES	YES	Input Type is TC
F.CJC (F.CJC)	Fix cold junction Compensation	0 to 60.0 °C	0.0	Input Type is TC & A.CJC is NO
F.KEY (F.KEY)	Function for A/M key	R- \bar{n} (Auto-Manual) / r-5(Run-Stop) / NoE	NONE	
PASS (PASS)	Password	0 to 99	1	
VERS (VERS)	Version	Shows the Version of the Current Firmware	-	

**For Fail-Safe Logic Alarm will work completely opposite to Normal behavior

CAL Mode

AMB (AMB)	Ambient	Ambient Adjustment	-	Input is TC
CALZ (CALZ)	Calibration Zero	SV Display : PV Input		
CALS (CALS)	Calibration Span	SV Display : PV Input		

*The value of FLTR will determine the ability of filtering noise. When a large value is set, the measurement input is stabilized but the response speed is slow. "FLTR" should be set to 0 or 1 to short the response time.

CONTROL FUNCTION

ON/OFF Control (For L-ON Mode): The relay is 'ON' up to the set temperature and cuts 'OFF' above the set temperature. As the temperature of the system drops, the relay is switched 'ON' at a temperature slightly lower than the set point.

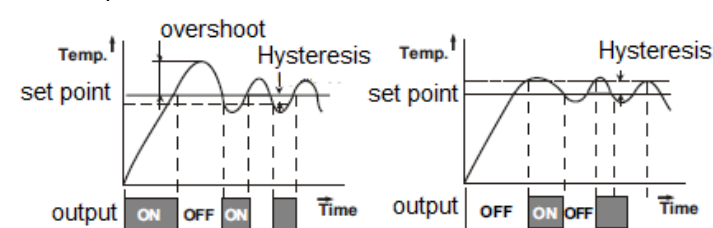

Figure 1.1: Typical Relay operation

HYSTERESIS: The difference between the temperatures at which relay switches 'ON' and at which the relay switches 'OFF' is the hysteresis or dead band.

PID Control

Auto Tuning: The Auto tuning process is performed at set point. Temperature will oscillate around the set point during tuning process. Set a set point to a lower value if overshooting around the normal process value is likely to cause damage. To start the auto tuning process, set the desired set point, select the parameter A.TUN in TUNE menu and set it to YES. During Auto tuning lower display (SV) will flash "AT" message. After auto tune procedure is completed, the message will be removed and controller will revert back to the PID control by using the new calculated PID values. The PID values obtained are stored in the nonvolatile memory.

AUTO TUNE FUNCTION:

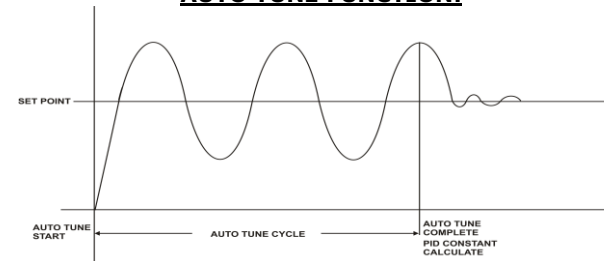

Manual Reset: After some time the process temperature settles at some point and there is a difference between the set temperature & the controlled temperature. This difference can be removed by setting the manual reset value equal & opposite to the offset. Range for the manual reset is -50.0% to +50.0% of proportional band.

Cycle Time: The Cycle time for output is the time where the output is on for percentage of that time and off for a percentage of that time, creating a portioning effect. The cycle time is only used where PI, PD or PID control action is used. The shorter the cycle time, the higher the proportionate resolution is, and better is the control.
For Relay output: Set to 10 to 300 seconds or more
For SSR output: Set to 1 to 60 seconds or more

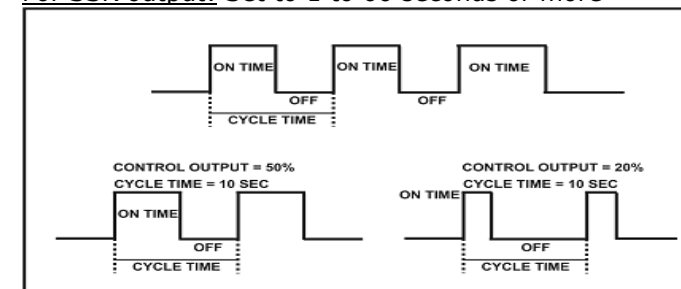

ALARM OUTPUT

Alarm Types:

Various alarm operations are shown in the reference figure.

Display message	ALARM TYPE	Display message	ALARM TYPE
none	None	SP.A.L	Absolute value set point low alarm
Pv.d.H	Deviation High alarm	P.S.d.H	Deviation High alarm with standby
Pv.d.l	Deviation Low alarm	P.S.d.L	Deviation Low alarm with standby
Pv.d.r	Deviation High & Low range alarm	P.S.d.r	Deviation High & Low range alarm with standby

	alarm		
Pv.d.b	Deviation High & Low Band alarm	P.S.d.b	Deviation High & Low limit alarm with standby
Pv.a.H	Absolute value High alarm	P.S.A.H	Absolute value High alarm with standby
Pv.A.L	Absolute value Low alarm	P.S.A.L	Absolute value Low alarm with standby
SP.A.H	Absolute value set point high alarm	PV.-E.	PV error (OPEN/OVER/UNDER)

NOTE-1: The fault diagnosis output turns on in case of input burnout (PV) failure.

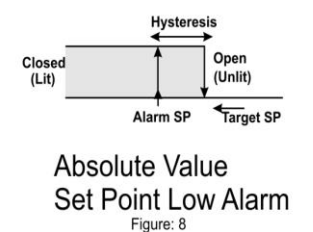
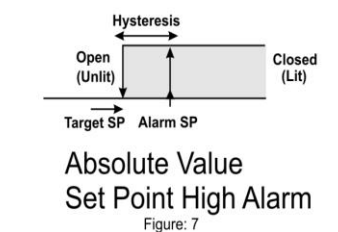
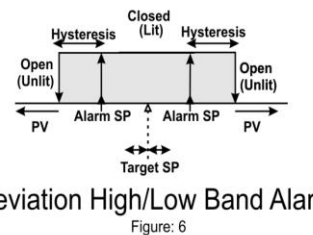
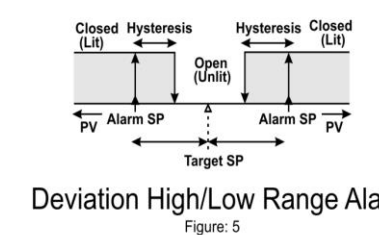
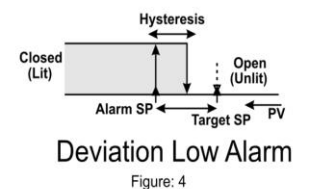
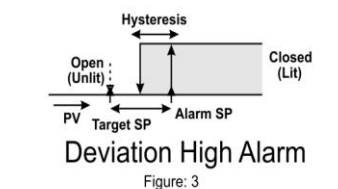
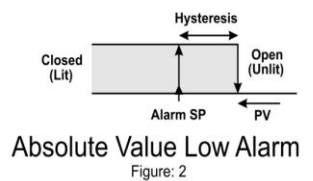
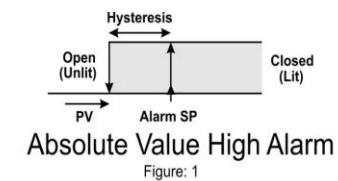

NOTE:-
 ➤ LIT = LED on, UNLIT = LED off
 ➤ Up arrow indicate Alarm will ON from this value.
 ➤ Down arrow indicate Alarm will OFF from this value.

For operation manual please visit www.masibus.com
 Specifications are subject to change without notice due to continuous improvements.

Masibus Automation And Instrumentation Pvt. Ltd.
 B-30, GIDC Electronics Estate, Sector-25, Gandhinagar-382044, Gujarat, India.
 Tel: +91 79 23287275-79 Fax: +91 79 23287281
 Web: www.masibus.com Email: support@masibus.com