

masibus®

User's Manual

FLAMEPROOF CONTROLLER

LC5296-XP

LC5296-XP-I

LC5296-XP-AT



Masibus Automation & Instrumentation Pvt. Ltd.

B/30, GIDC Electronics Estate,
Sector-25, Gandhinagar-382044, Gujarat, India
☎ +91 79 23287275-79 ☎ +91 79 23287281-82
Email: support@masibus.com
Web: www.masibus.com

Contents

1. INTRODUCTION.....	4
Foreword	4
Notice	4
Trademarks	4
Checking the Contents of the Package	4
Product Ordering Code	4
Safety Precautions	5
2. SPECIFICATIONS	6
2.1 Inputs	6
2.2 Display & Keys	6
2.3 Output Types.....	7
2.4 Communication Details	8
2.5 Power Supply	9
2.6 Environmental Conditions	9
3. PHYSICAL SPECIFICATIONS & MOUNTING DETAILS.....	9
3.1 External Dimensions & Penal Cutout Dimensions.....	9
4. TERMINAL CONNECTIONS	14
4.1 How to connect wires	15
5. FRONT PANEL DETAILS	17
5.1 Front Panel Description.....	18
6. MENU LAYOUT for LC5296-XP-AT.....	20
6.1 RUN Time Indication/Function.....	22
6.2 Set Point Setting.....	23
6.3 AUTO TUNE MODE	23
6.4 CONFIGURATION MODE.....	24
6.5 CALIBRATION MODE.....	29
7. MENU LAYOUT for LC5296-XP	31
7.1 RUN Time Indication/Function.....	33
7.2 Set Point Setting.....	34

7.3 CONFIGURATION MODE.....	34
7.4 CALIBRATION MODE.....	38
8. CONTROL FUNCTION.....	40
8.1 ON/OFF Control	40
8.2 PID Control.....	41
9. ALARM OUTPUT.....	44
9.1 ALARM TYPES	44
10. CALIBRATION PROCEDURE.....	47
10.1 Procedure for CAL-zero and CAL-span.....	47
10.2 Procedure for RET-zero and RET-span	47
11. COMMUNICATION PROTOCOL–MODBUS RTU.....	48
11.1 INTRODUCTION.....	48
11.2 Modbus Parameter Address.....	48
11.3 Exceptional Response.....	50
12. Appendix.....	52
12.1 Troubleshooting.....	52
12.2 ON-OFF LOGIC	53
12.3 RETRANSMISSION OUTPUT TABLE FOR OPEN /OVER /UNDER CONDITION	53
12.4 Control Output Table for OPEN/OVER/ UNDER Condition.....	54
12.5 Jumper Settings for Addon Card Selection & Retransmission	54
Output Type	54

1. INTRODUCTION

Foreword

Thank you for purchasing FLP(Flameproof) series

LC5296-XP-AT (PID with Auto Tuning + ON-OFF Controller) / LC5296-XP (ON-OFF Controller) /LC5296-XP-I (Indicator)

This manual describes the basic functions and operation methods. Please read through this user’s manual carefully before using the product.

Notice

The contents of this manual are subject to change without notice as a result of continuous improvements to the instrument’s performance and functions. Every effort has been made to ensure accuracy in the preparation of this manual. Should any errors or omissions come to your attention, however, please inform MASIBUS Sales office or sales representative. Under no circumstances may the contents of this manual, in part or in whole, be transcribed or copied without our permission.

Trademarks

Our product names or brand names mentioned in this manual are the trademarks or registered trademarks of Masibus Automation and Instrumentation (P) Ltd. (herein after referred to as **MASIBUS**). Adobe, Acrobat, and Postscript are either registered trademarks or trademarks of Adobe Systems Incorporated. All other product names mentioned in this user's manual are trademarks or registered trademarks of their respective companies.

Checking the Contents of the Package

Unpack the box and check the contents before using the product. If the product is different from which you have ordered, if any parts or accessories are missing, or if the product appears to be damaged, contact your sales representative.

Product Ordering Code

Model	Input		Power Supply		PV Display Size		Options					
							1 (AO1)		2(AO2 or RS485)		Gas Groups	
LC5296-XP	1	E	U1	85-265VAC / 125-300VDC	1	0.56"	N	None	N	None	1	IIA & IIB
LC5296-XP-I #	2	J	U2	18-36VDC	2	0.8"	1	4-20 mA	1	4-20 mA	2	IIA,IIB & IIC
	3	K					2	0-20 mA	2	0-20 mA		
	4	T					3	1-5V	3	1-5V		
	5	B					4	0-5V	4	0-5V		
	6	R					5	0-10V	5	0-10V		
	7	S							6	RS-485		
	9	Pt-100										
	C	1 to 5V										
	D	0 to 5V										
	E	4-20mA										
	F	0-20mA										

Options 1 and 2 are not available in this model

Model	Input		Power Supply		PV Display Size		Control Output		Option					
									1 (AO1*)		2 (AO2** or RS485)		Gas Groups	
LC5296-XP-AT	1	E	U1	85-265VAC / 125-300VDC	1	0.56"	1	Relay	N	None	1	None	1	IIA & IIB
	2	J	U2	18-36VDC	2	0.8"	2	SSR	1	4-20 mA	2	4-20 mA	2	IIA,IIB & IIC
	3	K							2	0-20 mA	3	0-20 mA		
	4	T							3	1-5V	4	1-5V		
	5	B							4	0-5V	5	0-5V		
	6	R							5	0-10V	6	0-10V		
	7	S										RS-485		
	9	Pt-100												
	C	1 to 5V												
	D	0 to 5V												
	E	4-20mA												
	F	0-20mA												

*Configurable as MV(%Power) or PV
 ** PV only

The Single Loop Controller unit has a nameplate affixed to the one side of the enclosure. Check the model and suffix codes inscribed on the nameplate to confirm that the product received is that which was ordered.

Safety Precautions

The product and the instruction manual describe important information to prevent possible harm to users and damage to the property and to use the product safely. Understand the following description (signs and symbols), read the text and observe Descriptions.

DESCRIPTION OF SIGNS

	WARNING	<i>This indicates a danger that may result in death or serious injury if not avoided.</i>
---	----------------	---

	CAUTION	<i>This indicates a danger that may result in minor or moderate injury or only a physical damage if not avoided.</i>
---	----------------	--

2. SPECIFICATIONS

2.1 Inputs

Analog Input	
Input Type	Thermocouple, RTD (Pt100), Current, Voltage
Display Range	Refer Table-2.1
Accuracy	± (0.25% of FS+ 1 degree) for T/C and RTD input. ± (0.1% of FS+ 1 count) for Linear input.
ADC Resolution	16 bits
Display Resolution	0.1°C / 1 Count
Sampling Rate	4 Samples/Sec
CJC Error	±3.0 °C Max
Sensor Burnout current	0.25uA
RTD excitation current	0.166mA (Approx)
Allowable wiring resistance for RTD	Maximum 15 ohms/wire (Conductor resistance between three wires should be equal)
NMRR	> 40 dB
CMRR	> 120 dB
Temp-co	< 150ppm/°C
Input Impedance	> 1MΩ (Voltage Input) 250Ω (Current Input)
Max Voltage	20VDC

Table-2.1 Input Display Range

Input type	Range
PT100 (0.1 °C)	-199.9 to 850.0 °C
PT100 (1 °C)	-200 to 850 °C
E	-200 to 1000 °C
J	-200 to 1200 °C
K	-200 to 1372 °C
T	-200 to 400 °C
B	450 to 1800 °C
R	0 to 1768 °C
S	0 to 1768 °C
*4-20mA /1-5VDC, *0-20mA /0-5VDC	-1999 to 9999 (Field Scalable)

*Use external 250ohms, 0.1% for current Input

2.2 Display & Keys

Model	Display	Specification
LC5296-XP-AT	PV Display	4-Digit, 7-Segment, Red, Character height of 0.56" or 0.8"

	SV / Parameter Display	4-Digit, 7-Segment, Green, Character height of 0.40"
	Status Indication	Individual RED Led for Relay, SSR Output, Manual Status, communication(Rx &Tx) Status
LC5296-XP	PV Display	4-Digit, 7-Segment, Red, Character height of 0.56" or 0.8"
	SV / Parameter Display	4-Digit, 7-Segment, Green, Character height of 0.40"
	Status Indication	Individual RED Led for Relay Status& communication(Rx &Tx) Status
LC5296-XP-I	PV Display	4-Digit, 7-Segment, Red, Character height of 0.56" or 0.8"
	Status Indication	Individual RED Led for Relay Status& communication(Rx &Tx) Status (Available based on Ordering Code)

2.3 Output Types

Output types are software selectable from the Key board or Modbus.

Model	Output Type	Description
LC5296-XP-AT	Relay Output	2 Relays <u>Relay-1</u> <ul style="list-style-type: none"> • For PID or ON-OFF Controlling. • Used as Alarm-1 Output if Output Type is Linear <u>Relay-2</u> <ul style="list-style-type: none"> • Alarm-2 Output
	SSR Output *	Voltage Pulse Output Available at Terminals of Relay-1
	Linear Output	Available at Terminals of Retransmission-1. Linear Output Type as per selection in Retransmission-1 Output Type.
LC5296-XP	Relay Output	2 Relays for ON-OFF Controlling
LC5296-XP-I	Relay Output	2 Relays for ON-OFF Controlling (Optional)

- Also, Output Direction [Direct(Cooling) /Reverse (Heating)] is selectable from software.
- At a time unit can support Relay or SSR Output. (Factory settable)(Specify in Order Code)

Relay Output	
Relays	1 (For LC5296-XP-AT) 2 (For LC5296-XP) Optional For LC5296-XP-I
Type	Single Change over Three Terminals (C, NO, NC)

Rating	2A @ 230VAC / 30VDC
--------	---------------------

Pulse Output (SSR)(For LC5296-XP-AT Only)	
Output signal	Voltage Pulse Output
Output signal On-condition	11VDC or more
Off-condition	2VDC or less
Resolution	10 ms
Linear Output (For LC5296-XP-AT Only)	
Output Signal	Voltage (0-5VDC, 1-5VDC, 0-10VDC) @3kΩ Min Current (4-20mADC, 0-20mADC) @500Ω Max

Retransmission Output	
Number of output	1 (@Retransmission-2)(For Linear Output Type) or 2 (@Retransmission-1&2)(For Relay or SSR Output Type)
Output According to	Process Value
Output Signal	4-20mA / 0-20mA /1-5VDC / 0-5VDC / 0-10V DC
Load resistance	< 500Ω > 3KΩ
<ul style="list-style-type: none"> • For Current o/p • For Voltage o/p 	
Output accuracy	±0.25% of span

Alarm Output (For LC5296-XP-AT Only)	
Number of Outputs	2 if Output Type is Linear(@Relay-1&2), 1 if Output Type is Relay or SSR(@Relay-2) Control relays are available as alarm outputs
Output signal	Three terminals (NC, NO, and C)
Purpose	Alarm output and others. (See Alarm and Digital outputs function)
Relay contact rating	250 V AC or 30 V DC, 2A (resistive load)

Loop Power Supply	
Supply Voltage	24VDC (±1V) @26mA with Inbuilt Short Circuit Protection
Minimum load resistance	800 ohms

2.4 Communication Details

Communication	
Interface	RS485 (2 Wire)
Protocol	Modbus-RTU
Baud rate	9600, 19200, 38400 bps

2.5 Power Supply

Standard	85-265VAC/ 125-300VDC
Optional	18-36VDC
Power consumption	<10 VA
Data backup	Non-volatile memory (can be written up to 100000 times)

➤ Isolation (Withstanding voltage)

- Between primary terminals* and secondary terminals**:
At least 1500 V AC for 1 minute
- Between primary terminals* and grounding terminal:
At least 1500 V AC for 1 minute
- Between grounding terminal and secondary terminals**:
At least 1500 V AC for 1 minute
- Between secondary terminals**:
At least 500 V AC for 1 minute

* Primary terminals indicate power terminals and relay output terminals.

** Secondary terminals indicate analog I/O signal and Communication O/P.

- **Insulation resistance:** 20MΩ or more at 500 V DC between power terminals and grounding terminal.

2.6 Environmental Conditions

TEMPCO	For Input to PV Display < 100ppm. FOR Display to Retransmission and Control output < 100ppm
Humidity	30% to 95% RH (Non-Condensing)
Instrument Warm-up Time	Approx. 15 minutes
Ambient temperature	0 to 55°C
Storage Temperature	0 to 80°C

3. PHYSICAL SPECIFICATIONS & MOUNTING DETAILS

3.1 External Dimensions & Penal Cutout Dimensions

Unit: mm

Mounting method: Wall Mounting

Weight: For IIA, IIB & IIC Enclosure : Approx. 3 Kg.

For IIA & IIB Enclosure : Approx. 2.6 Kg.

Type of Protections: Flameproof (Explosion Proof) EX-d

Area Classification: Hazardous Location of Zone 1 & 2

Gas Groups: IIA, IIB & IIC

IP Protection: IP 66

<u>Apparatus Standard:</u>	IS 2148-2004 & IS-13346-2004
<u>Material:</u>	Aluminum Alloy LM-6.
<u>Finish:</u>	Anti corrosive epoxy light grey shade- 631 of IS:5
<u>Hardware:</u>	High tensile zinc passivated / stainless steel (ss-304)
<u>Mountings:</u>	Wall mountings with the help of 4 NOS bolts of size M8
<u>Cable entry size/no:</u>	¾" ET – 5 NOS
<u>Plug Details:</u>	3 Blind Plug & 2 Cable gland ¾"ET

1. Mechanical Details for IIA &IIB Enclosure

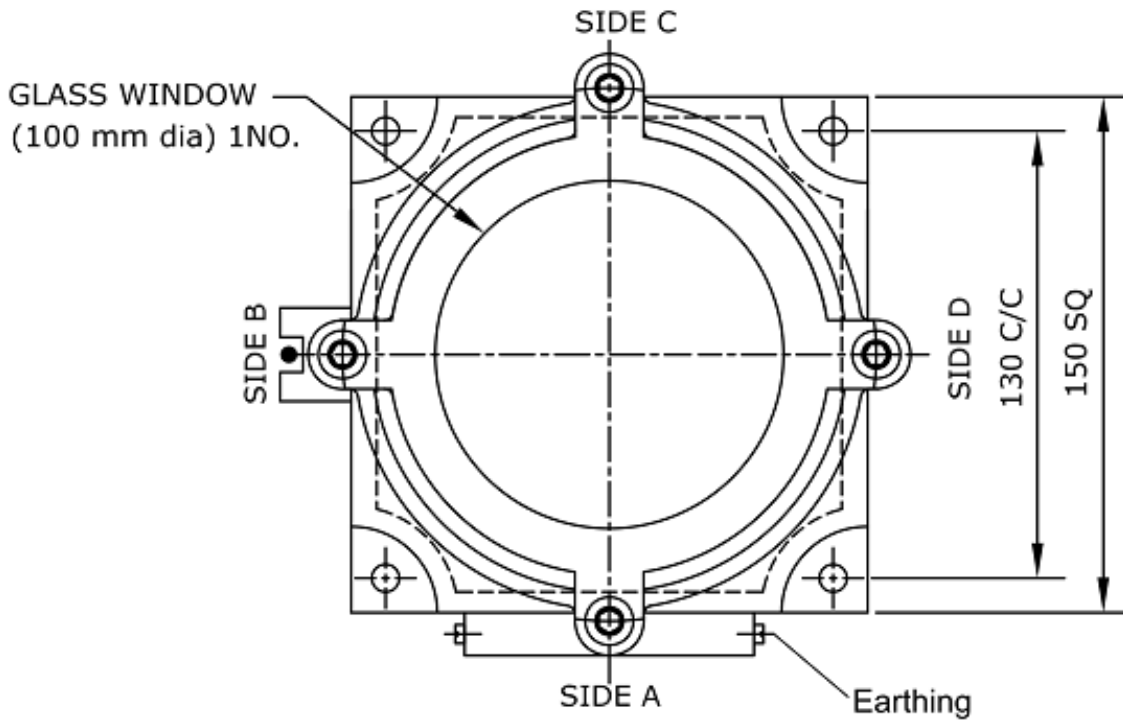

TOP FRONTVIEW OF DEVICE

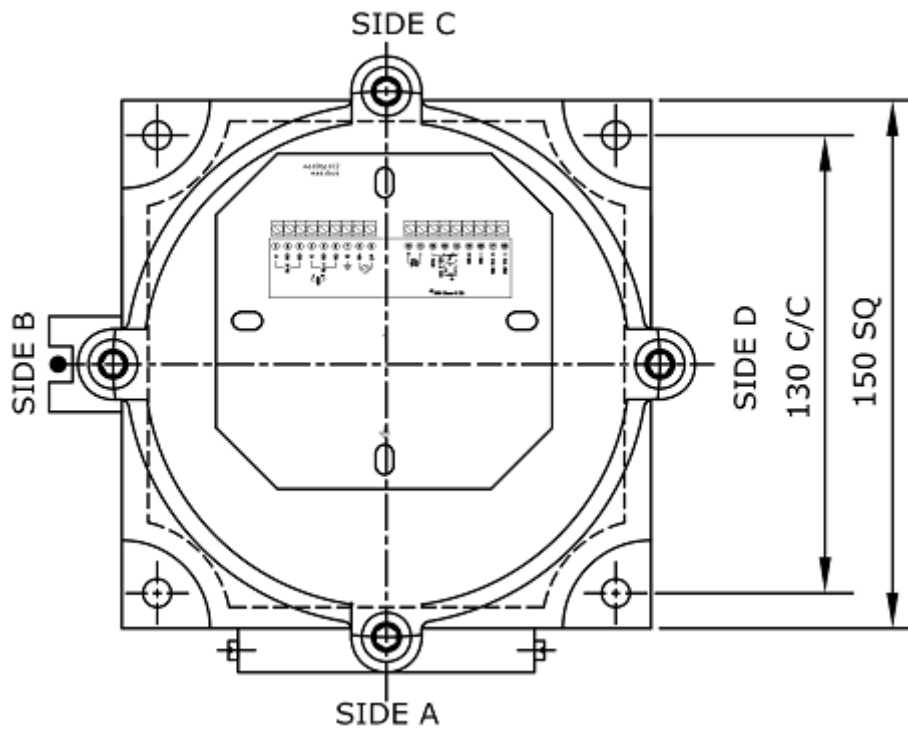

INTERNAL VIEW WITH TERMINAL CONNECTION DETAILS

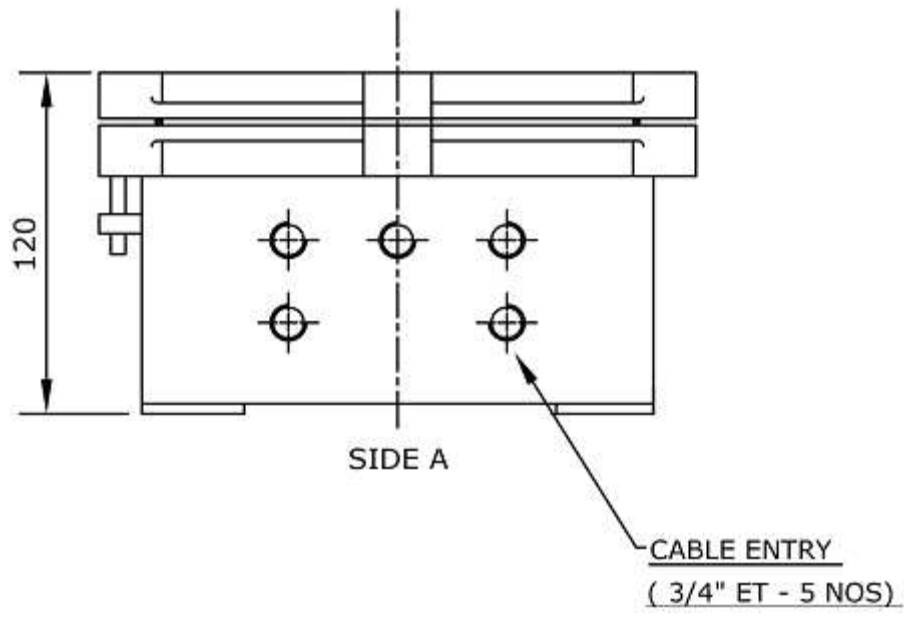

BOTTOM VIEW FOR CABLE ENTRY

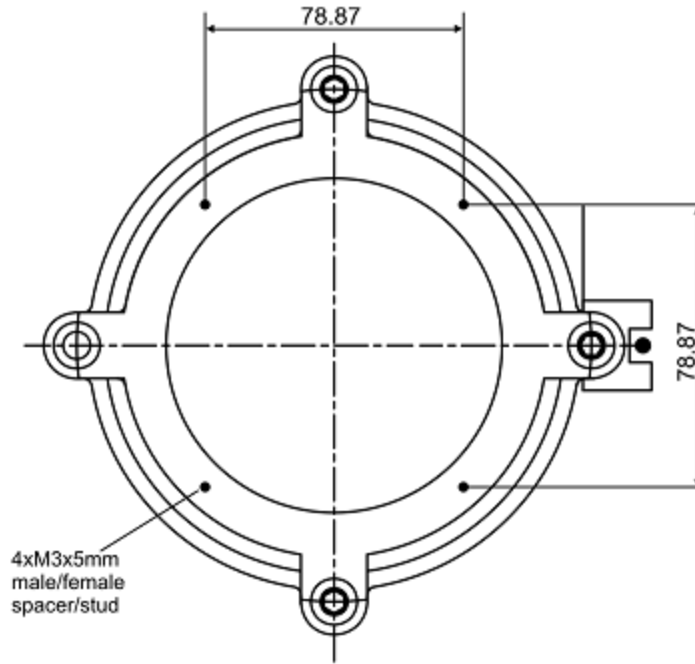

TOP VIEW FOR DISPLAY CARD ASSEMBLY

2. Mechanical Details for IIA, IIB & IIC Enclosure

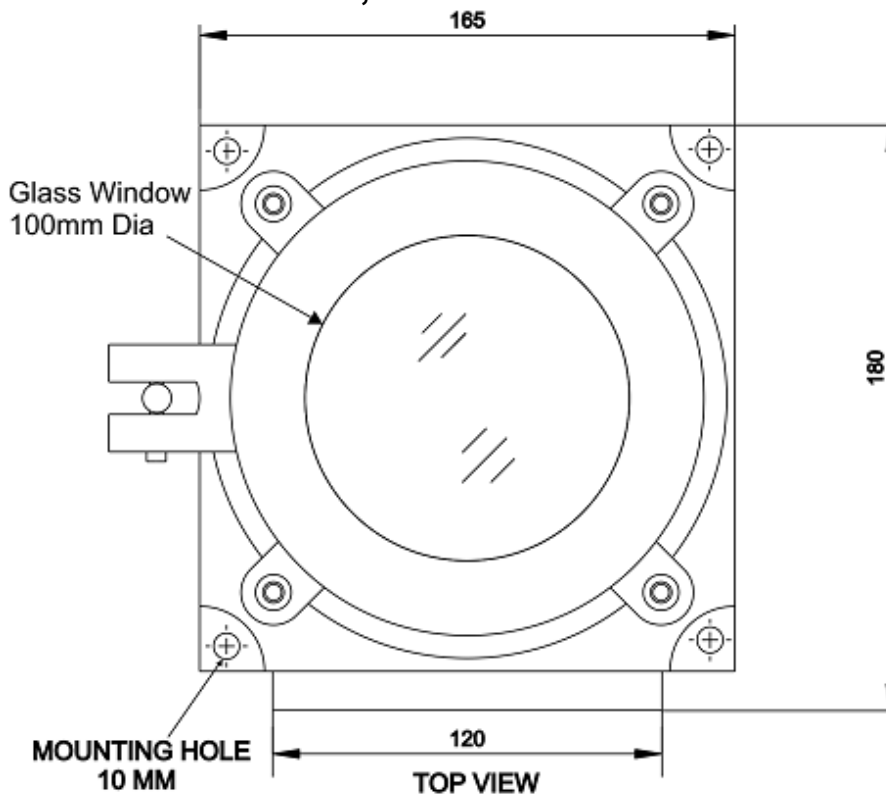

FRONT VIEW OF DEVICE

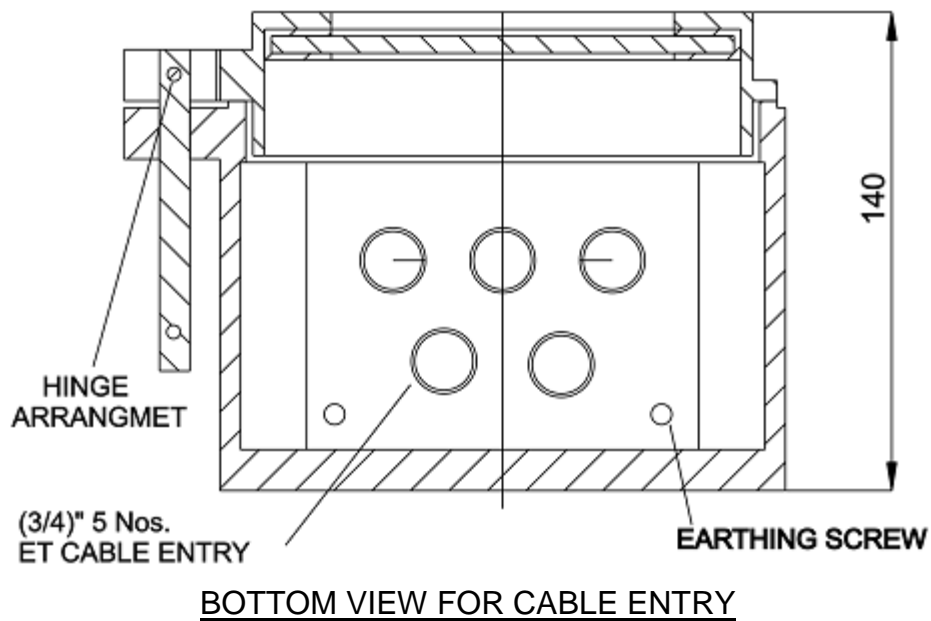
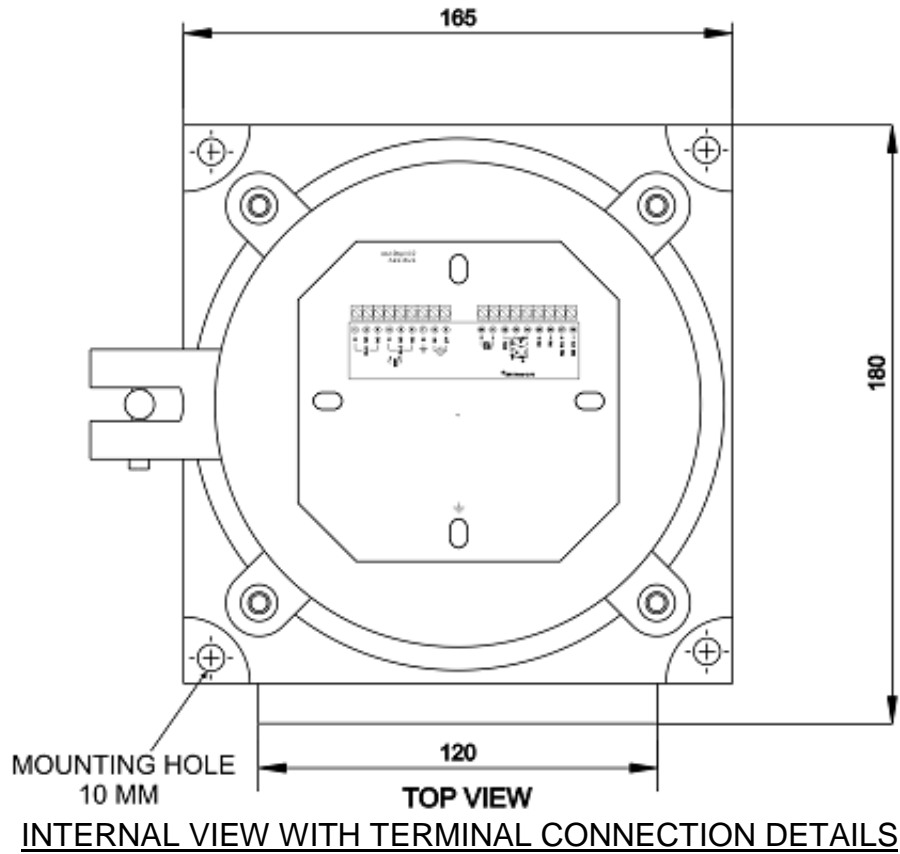

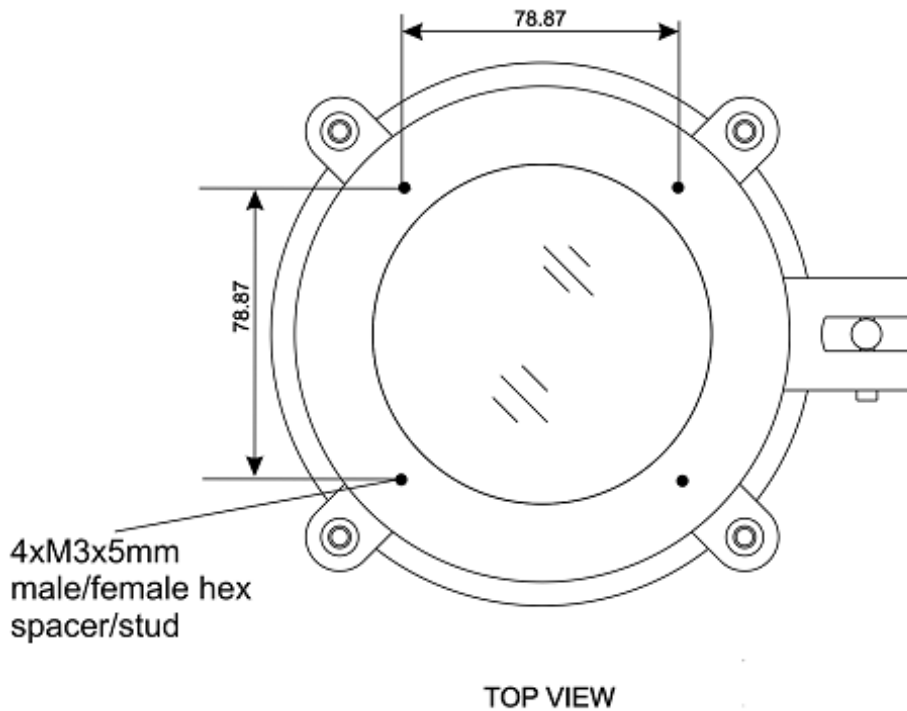

TOP VIEW FOR DISPLAY CARD ASSEMBLY

4. TERMINAL CONNECTIONS

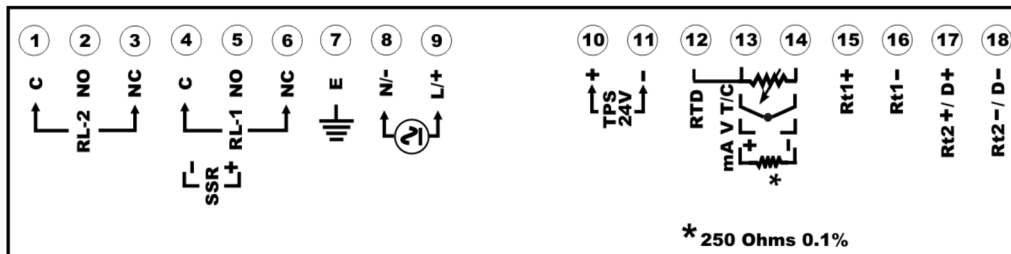

Figure 4.1: Terminal connection

Terminal No.	Description	
1 (C2)	• For Relay-2 potential free Contacts (Use 230V -2A load)	
2 (NO2)	• Alarm-2 o/p.	LC5296-XP-AT
3 (NC2)	• ON-OFF control	LC5296-XP
4 (C1)	• For Relay-1 potential free Contacts (Use 230V -2A load)	
5 (NO1)	• PID / On-Off Control o/p.	LC5296-XP-AT
6 (NC1)	• Alarm-1 o/p, if output type is Linear. • Terminal 4,5:- SSR Pulse o/p.	
	• ON-OFF control	LC5296-XP
7 (Earth)	Earth Connection	
8 (N/-)	Power Supply Input	
9 (L/+)	Power Supply Input	

10 (TPS+) 11 (TPS-)	24VDC Loop power supply
12	For RTD Input Only (Three wire Compensation).
13 (TC+ / V+) 14 (TC- / V-)	For Thermocouple, RTD & Linear Input
15 (Linear Output+/RTR1+) 16 (Linear Output-/RTR1-)	<ul style="list-style-type: none"> • For Retransmission-1 output • Linear type Control Output
17 (D+ / RTR2+) 18 (D- / RTR2-)	<ul style="list-style-type: none"> • For Retransmission-2 output • Modbus-RTU Communication Output

4.1 How to connect wires

Before carrying out wiring, turn off the power to the controller and check that the cables to be connected are not alive because there is a possibility of electric shock.

NOTE:



- ✓ All wiring must confirm to appropriate standards of good practice and local codes and regulations. Wiring must be suitable for Voltage, Current and temperature rating of the system.
- ✓ Terminal Details: $\leq 2.5\text{mm}^2$ conductor
- ✓ Provide power from a single-phase instrument power supply. If there is a lot of noise in the power line, insert an insulating transformer into the primary side of the line and use a line filter on the secondary side. Do not place the primary and secondary power cables close to each other.
- ✓ For thermocouple input, use shielded compensating lead wires for wiring. For RTD input, use shielded wires that have low conductor resistance and cause no significant differences in resistance between the three wires. Do not connect Terminal – 12 when thermocouple or Linear input is selected.
- ✓ Use repeater after each set of 32 instruments connected in RS-485 Communication.
- ✓ Unused terminals should not be used as jumper points as they may be internally connected, which may cause damage to the unit.
- ✓ Unused control terminals should not be used as jumper points as they might be internally connected, which may cause damage to the unit.
- ✓ Use $>250\text{V}-1\text{Amp}$ Cable for Power Supply.
- ✓ Supply voltage must be below maximum voltage rating specified on the label
- ✓ If cable has two parallel wires inside then isolation between them must be 2.5 KV.

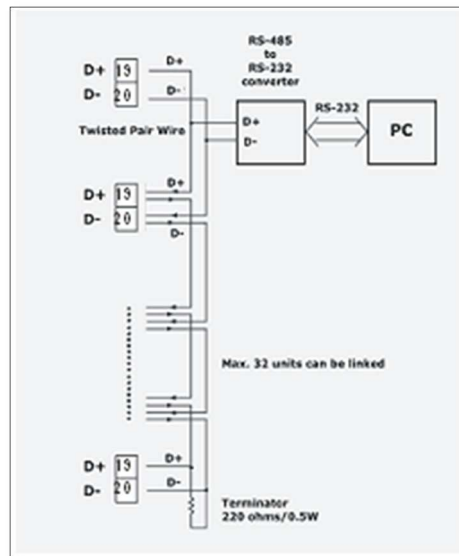

Fig 4.2: RS485 Connection Details



CAUTION:



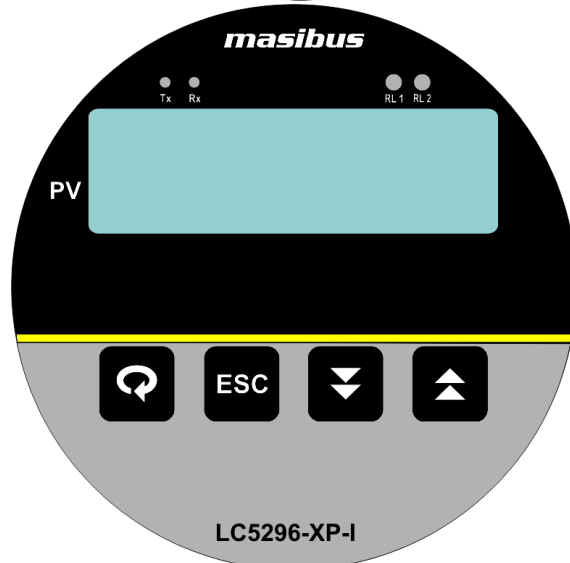
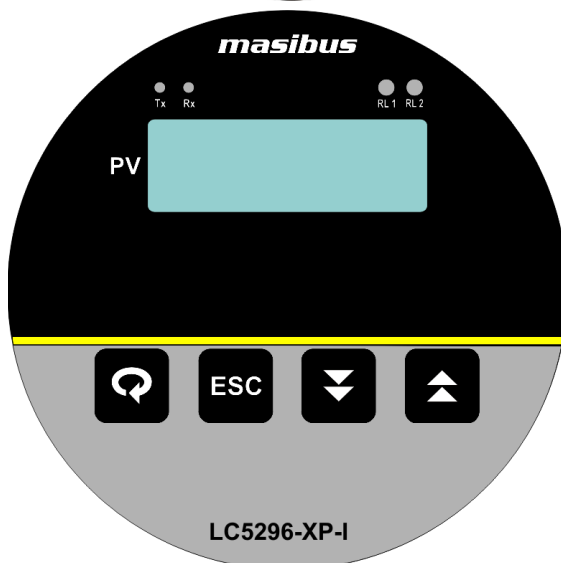
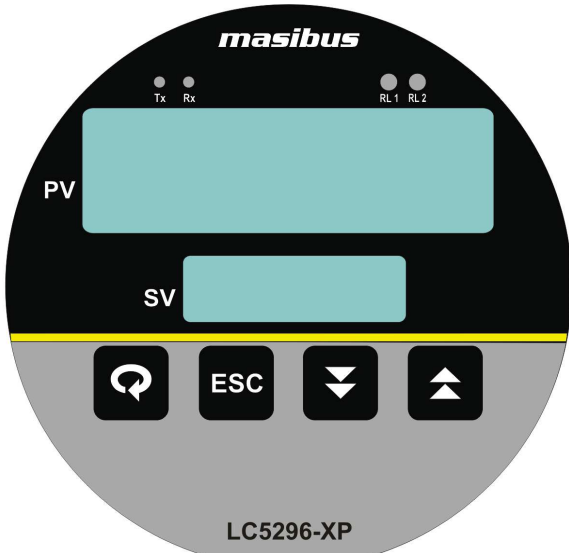
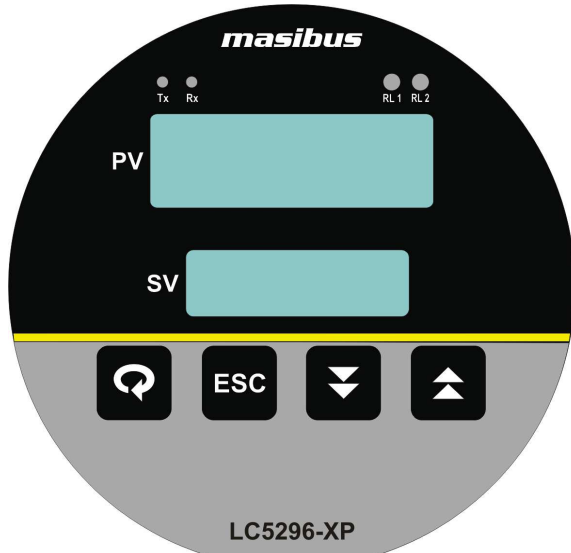
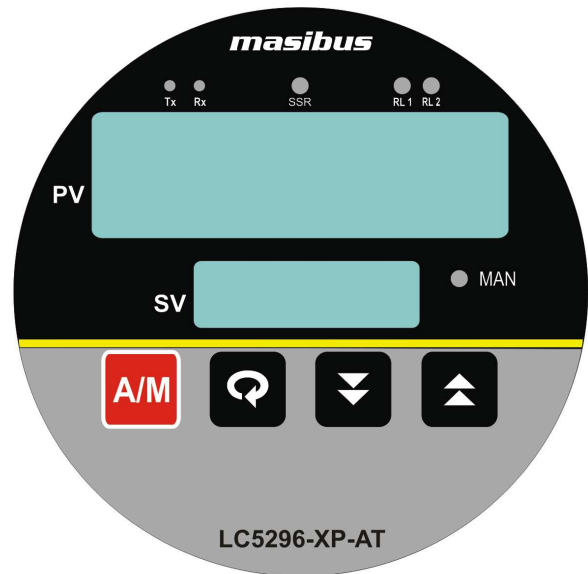
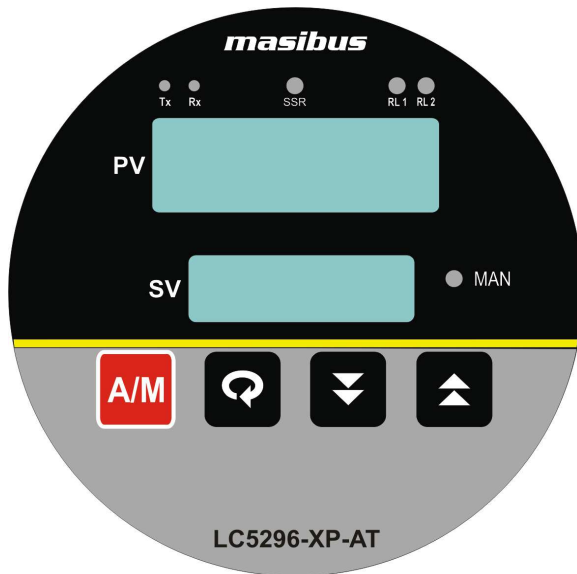

High voltage transients may occur when switching inductive loads such as some contactors or solenoid valves. Through the internal contacts, these transients may introduce disturbances which could affect the performance of the instrument.

For this type of load it is highly recommended that a “snubber” is connected across the normally open contact of the relay switching through load. The snubber recommended consists of a series connected resistor/capacitor (typically 15nF/100Ohms). A snubber will also prolong the life of the relay contacts. A snubber should also be connected across the output of a triac output to prevent false triggering under line transient conditions.

5. FRONT PANEL DETAILS



5.1 Front Panel Description

Name of Part	Symbol	Function	LC5296-XP-AT	LC5296-XP
Increment Key		<ul style="list-style-type: none"> • Enter into Edit Mode. • Increment the Value of any Parameter in edit mode. • Shows Ambient value for T/C Input in RUN mode. • In Manual Mode this key is used to Increment the %Power. (for LC5296-XP-AT Only) 	✓	✓
Decrement Key		<ul style="list-style-type: none"> • Enter into Edit Mode. • Decrement the Value of any Parameter in edit mode. • Shows %Power value if Device is in Auto Mode during RUN mode. (for LC5296-XP-AT Only) • In Manual Mode this key is used to Decrement the %Power. (for LC5296-XP-AT Only) 	✓	✓
SET Key (Menu / Enter Key)		<ul style="list-style-type: none"> • Shows Different Set Point, if this pressed in RUN mode. • It is used to enter in the sub menu (TUNE, CONF, CAL) • In Sub Menu it can be used to get to the next Parameter. • It is also used to save the parameters to nonvolatile memory, when user setting a proper data by Increment and decrement key for parameter configuration. 	✓	✓
Escape Key		<ul style="list-style-type: none"> • Get to the Previous Menu level. 	✗	✓
Auto/Manual Key		<ul style="list-style-type: none"> • It is used to switch between Auto to Manual mode and Manual to Auto mode if pressed for at least 2 sec. 	✓	✗
PV (Process Value) Display	PV	<ul style="list-style-type: none"> • 4 digital 0.56 inch RED Display • Display process value. • Display parameter name when user set parameter. • Display error message when an error occurs. 	✓	✓
SV (Set Value) Display	SV	<ul style="list-style-type: none"> • 4 digital 0.4 inch GREEN • Display set value. • Display parameter value of parameter in process value field when user set parameter. • Display control output value when in manual mode. 	✓	✓
Relay-1 Indication	RL1	<ul style="list-style-type: none"> • ON when Relay-1 is energized & OFF otherwise. 	✓	✓

Relay-2 Indication	RL2	<ul style="list-style-type: none"> • ON when Relay-2 is energized & OFF otherwise. 	✓	✓
SSR Indication	SSR	<ul style="list-style-type: none"> • SSR ON status. 	✓	✘
MANUAL Indication	MAN	<ul style="list-style-type: none"> • ON when unit is in Manual mode. • OFF when unit in Auto Mode. 	✓	✘
TX Indication	Tx	<ul style="list-style-type: none"> • ON when device is transmitting some Data (RS-485). 	✓	✓
RX Indication	Rx	<ul style="list-style-type: none"> • ON when device is receiving some Data (RS-485). 	✓	✓

NOTE:

✓ : Available for this Model.

✘ : Not Available for this Model.

6. MENU LAYOUT for LC5296-XP-AT

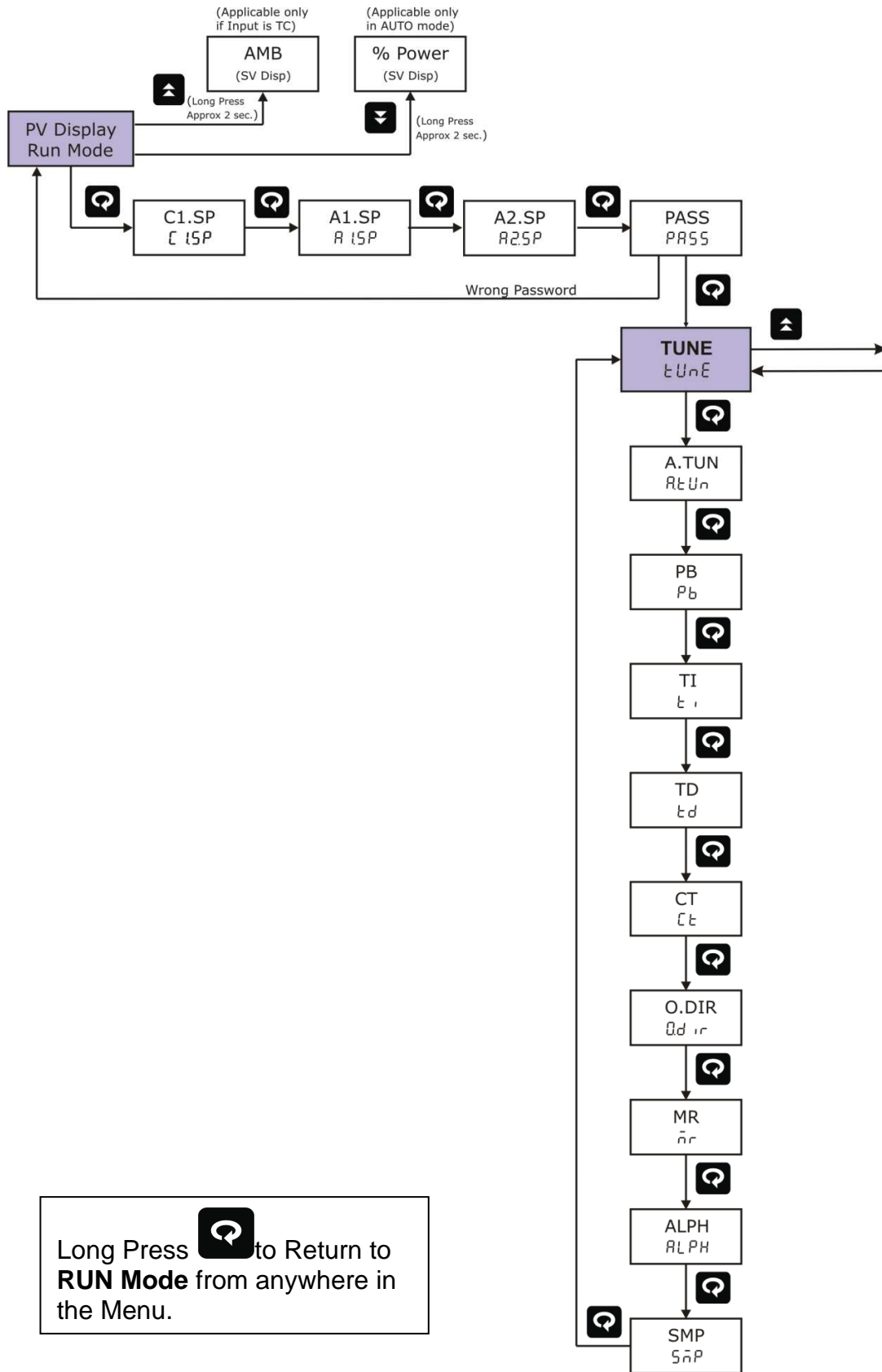

Long Press  to Return to **RUN Mode** from anywhere in the Menu.

MENU LAYOUT for LC5296-XP-AT

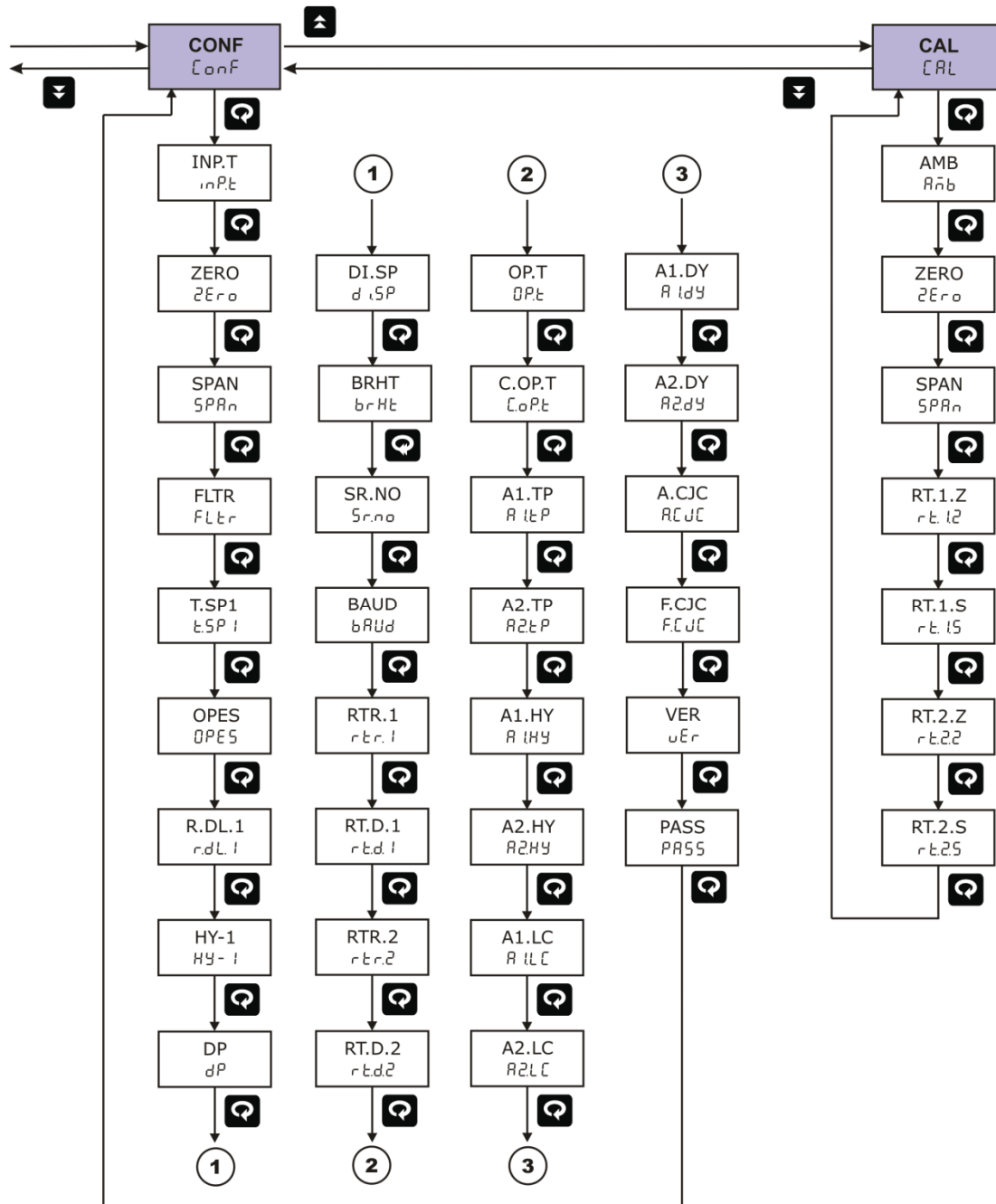

6.1 RUN Time Indication/Function

Following parameters can view or change during run time.

- Press Decrement key to show percentage power Auto Mode (0.0 to100.0%)
- For Thermocouple input type, Press Increment key to show ambient temperature.
- During manual mode, Increment key and Shift Decrement Key will use to modify the percentage power.

- Press  to toggle between AUTO & MANUAL mode.

6.2 Set Point Setting

Set Point Setting:				
Parameter (PV display)		Setting name and description	Default value	Shows only if
Symbol	Name			
C1.SP (C1.sp)	Control Set Point 1	Range Depending on PV sensor type selected	100	-
A1.SP (A1.sp)	Alarm Set Point 1	Range Depending on PV sensor type selected	100	Output Type is LIN(Linear)
A2.SP (A2.sp)	Alarm Set Point 2	Range Depending on PV sensor type selected	200	-

6.3 AUTO TUNE MODE

AUTOTUNE PARAMETERS				
Parameter (PV display)		Setting Name & Description	Default Value	Show if Only
Symbol	Name			
A.TUN (A.tun)	Auto Tune	Start / Stop Auto Tuning Process yes / no 0 : NO (Stop Auto Tuning) 1 : YES (Start Auto Tuning)	NO	Control Type is PI or PID
PB (pb)	Proportional Band	Adjust Proportional Band 0 to 9999 or 0.0 to 999.9	10.0	Control Type is P or PI or PID
TI (ti)	Integral Time	Adjust Integral Time 0 to 1000	60	Control Type is PI or PID
TD (td)	Derivative Time	Adjust Derivative Time 0 to 180	0	Control Type is PID
CT (ct)	Cycle Time	Adjust Cycle Time For, SSR o/p: (1 – 60 sec) Relay o/p: (10 – 300 sec)	1 or 10	
O.DIR (o.dir)	Output Direction	Set Output Direction dir/ rev 0 : REV (REVERSE)	0 (REV)	Control Type is P or PI or PID

		1 : DIR (Direct)																		
MR (mr)	Manual Reset	<p>Adjust Manual Reset Value It is used to shift P Band for critical Controlling situations. (Applicable only if Control O/P is "P")</p> <p>-(PB/2) to +(PB/2)</p> <p>EX. If PB = 50, SP = 100, O.DIR = REV</p> <p><u>MR = 0MR = 25</u></p> <table border="1"> <tr> <th>PV</th> <th>% POWER</th> <th>PV</th> <th>%POWER</th> </tr> <tr> <td><= 75</td> <td>100 %</td> <td><= 100</td> <td>100 %</td> </tr> <tr> <td>100</td> <td>50 %</td> <td>125</td> <td>50 %</td> </tr> <tr> <td>>= 125</td> <td>0 %</td> <td>>= 150</td> <td>0 %</td> </tr> </table>	PV	% POWER	PV	%POWER	<= 75	100 %	<= 100	100 %	100	50 %	125	50 %	>= 125	0 %	>= 150	0 %	0	Control Type is P
PV	% POWER	PV	%POWER																	
<= 75	100 %	<= 100	100 %																	
100	50 %	125	50 %																	
>= 125	0 %	>= 150	0 %																	
ALPH (alpH)	Sampling Rate	<p>Adjust Sampling Rate Its acts like Derivative Factor. It is used to decrease effect of D term in PID output for some critical operating condition</p> <p>0.01 to 1.00</p>	1.00	Control Type is PID																
SMP (smp)	Sampling Period	<p>Set Sampling Period for Derivative Term</p> <p>200 / 500 / 1</p> <p>0 : 200 ms 1 : 500 ms 2 : 1 sec</p>	0 (200 ms)	Control Type is PID																

6.4 CONFIGURATION MODE

CONFIGURATION PARAMETERS																															
Parameter (PV display)		Setting Name & Description	Default Value	Show if Only																											
Symbol	Name																														
INP.T (inp.t)	INPUT Type	<p>Set PV Input Type</p> <p>tC e / tC j / tC K / tC t / tC b / tC r / tC s / rtd.1 / rtd/ 0-5v / 1-5v</p> <table border="1"> <thead> <tr> <th>Value</th> <th>Input Type</th> <th>Range</th> </tr> </thead> <tbody> <tr> <td>0</td> <td>TC E</td> <td>-200 to 1000 °C</td> </tr> <tr> <td>1</td> <td>TC J</td> <td>-200 to 1200 °C</td> </tr> <tr> <td>2</td> <td>TC K</td> <td>-200 to 1372 °C</td> </tr> <tr> <td>3</td> <td>TC T</td> <td>-100 to 400 °C</td> </tr> <tr> <td>4</td> <td>TC B</td> <td>450 to 1800 °C</td> </tr> <tr> <td>5</td> <td>TC R</td> <td>0 to 1768 °C</td> </tr> <tr> <td>6</td> <td>TC S</td> <td>0 to 1768 °C</td> </tr> <tr> <td>7</td> <td>RTD.1</td> <td>-199.9 to 850.0 °C</td> </tr> </tbody> </table>	Value	Input Type	Range	0	TC E	-200 to 1000 °C	1	TC J	-200 to 1200 °C	2	TC K	-200 to 1372 °C	3	TC T	-100 to 400 °C	4	TC B	450 to 1800 °C	5	TC R	0 to 1768 °C	6	TC S	0 to 1768 °C	7	RTD.1	-199.9 to 850.0 °C	TC E	
Value	Input Type	Range																													
0	TC E	-200 to 1000 °C																													
1	TC J	-200 to 1200 °C																													
2	TC K	-200 to 1372 °C																													
3	TC T	-100 to 400 °C																													
4	TC B	450 to 1800 °C																													
5	TC R	0 to 1768 °C																													
6	TC S	0 to 1768 °C																													
7	RTD.1	-199.9 to 850.0 °C																													

		<table border="1"> <tr> <td>8</td> <td>RTD</td> <td>-200 to 850 °C</td> </tr> <tr> <td>9</td> <td>0-5 V / 0-20 mA*</td> <td rowspan="2">-1999 to 1999</td> </tr> <tr> <td>10</td> <td>1-5 V / 4-20 mA*</td> </tr> </table> <p>*Use external 250ohms,0.1% for current input</p>	8	RTD	-200 to 850 °C	9	0-5 V / 0-20 mA*	-1999 to 1999	10	1-5 V / 4-20 mA*						
8	RTD	-200 to 850 °C														
9	0-5 V / 0-20 mA*	-1999 to 1999														
10	1-5 V / 4-20 mA*															
ZERO (zero)	Zero	<p>Automatically change to the Input Lower Range with changing of Input Type (Refer Above Table)</p> <p>Can be set to any value within the Input Range & less the SPAN Value.</p>	-200 (If TC E)													
SPAN (span)	Span	<p>Automatically change to the Input Higher Range with changing of Input Type (Refer Above Table)</p> <p>Can be set to any value within the Input Range & greater the ZERO Value.</p>	1000 (If TC E)													
FLTR (fltr)	Filter	<p>Filter for PV Input</p> <p>no / yes</p> <p>0 : NO 1 : YES</p>	1 (YES)													
T.SP1 (t.sp1)	Type of Set Point	<p>Set Type of Set Point</p> <p>1-on / H-on</p> <p>0 : L-ON (Lower ON) 1 : H-ON (Higher ON)</p> <p>Refer ON-OFF Control on Page:40</p>	0 (L-ON)	Control Type is ON-OFF. (Not available for Linear O/P)												
OPES (opes)	OPEN Sensor Status	<p>Set Control O/P & Retransmission state when Input OPEN condition.</p> <p>down / up</p> <p>0 : DOWN 1 : UP</p>	0 (DOWN)													
R.DL.1 (r.dl.1)	Relay Delay (For Relay-1)	<p>Relay Delay is amount of time (in sec), that Relay will wait before getting ON after the ON condition occurs.</p> <p>1 to 99 sec</p>	1 sec	Control Type is ON-OFF												
HY-1 (Hy-1)	Hysteresis – 1 (For Relay-1)	<p>Hysteresis Value (in °C) for Relay-1 during ON-OFF type Control.</p> <table border="1"> <tr> <td>1 to 100</td> <td>TC & RTD Input</td> </tr> <tr> <td>0.1 to 100.0</td> <td>RTD.1 Input</td> </tr> <tr> <td>1 to 100</td> <td>Linear Input with DP=0</td> </tr> <tr> <td>0.1 to 100.0</td> <td>Linear Input with DP=1</td> </tr> <tr> <td>0.01 to 10.00</td> <td>Linear Input with DP=2</td> </tr> <tr> <td>0.001 to 1.000</td> <td>Linear Input with DP=3</td> </tr> </table>	1 to 100	TC & RTD Input	0.1 to 100.0	RTD.1 Input	1 to 100	Linear Input with DP=0	0.1 to 100.0	Linear Input with DP=1	0.01 to 10.00	Linear Input with DP=2	0.001 to 1.000	Linear Input with DP=3	5	Control Type is ON-OFF
1 to 100	TC & RTD Input															
0.1 to 100.0	RTD.1 Input															
1 to 100	Linear Input with DP=0															
0.1 to 100.0	Linear Input with DP=1															
0.01 to 10.00	Linear Input with DP=2															
0.001 to 1.000	Linear Input with DP=3															

DP (dp)	Decimal Point	Set position of Decimal Point on Display. 0 / 0.0 / 0.00 / 0.000 0 : 0 1 : 0.0 2 : 0.00 3 : 0.000	0	Input Type is Linear
DI.SP (di.sp)	Display Set Point	Set which Set Point to shown in SV display in RUN mode while device is in Auto Mode C1.sp / A2.sp / A1.sp 0 : C1.SP (Control Set Point 1) 1 : A2.SP (Alarm Set Point 2) 2 : A1.SP (Alarm Set Point 1)	0	Output Type is Relay or SSR then A1.SP will not appear.
BRHT (brHt)	Brightness	Adjust Brightness of the 7-segment Display. 10 to 100	50	
SR.NO (sr.no)	Serial No.	Unit ID for Modbus-RS485 Communication 1 to 247	1	Device supports RS485 Communication.
BAUD (baud)	Baud Rate	Set Modbus RS485 Communication Baud Rate 9600 / 19.2k / 38.4k 0 : 9600 (9600 bps) 1 : 19.2K (19200 bps) 2 : 38.4K (38400 bps)	0 (9600)	Device supports RS485 Communication.
RTR.1 (rtr.1)	Retransmission 1 Type	Retransmission-1 Output Type This output is according to PV input. Zero & Span acts as Min & Max value of retransmission o/p scale respectively. 0-5v / 1-5v / 0-10v / 4-20 / 0-20 0 : 0-5V 1 : 1-5V 2 : 0-10V 3 : 4-20mA 4 : 0-20mA Voltage or Current is Jumper Selectable from the Hardware.	3 (4-20mA)	Device Supports Retransmission Output.

<p>RT.D.1 (rt.d.1)</p>	<p>Retransmission -1 Direction</p>	<p>Set Direction for the Retransmission Output-1</p> <p>rev / dir</p> <p>0 : REV (REVERSE) 1 : DIR (DIRECT)</p> <p>EX. If i/p is RTD.1, ZERO=0, SPAN=600, RTR.1=4-20mA &</p> <p>RT.D.1=DIR when PV = 0, RTR o/p = 4mA PV = 300, RTR o/p = 12mA PV = 600, RTR o/p = 20mA</p> <p>RT.D.1=REV when PV = 0, RTR o/p = 20mA PV = 300, RTR o/p = 12mA PV = 600, RTR o/p = 4mA Refer Retransmission o/p table on Page 53 for more info.</p>	<p>1 (DIRECT)</p>	<p>Device Supports Retransmission Output& OP.T (Output Type) is not LINEAR.</p>
<p>RTR.2 (rtr.2)</p>	<p>Retransmission 2 Type</p>	<p>Retransmission-2 Output Type This output is according to PV input. Zero & Span acts as Min & Max value of retransmission o/p scale respectively.</p> <p>0-5v / 1-5v / 0-10v / 4-20 / 0-20</p> <p>0 : 0-5V 1 : 1-5V 2 : 0-10V 3 : 4-20mA 4 : 0-20mA</p> <p>Voltage or Current is Jumper Selectable from the Hardware.</p>	<p>3 (4-20mA)</p>	<p>Device Supports Dual Retransmission Output.</p>
<p>RT.D.2 (rt.d.2)</p>	<p>Retransmission -2 Direction</p>	<p>Set Direction for the Retransmission Output-2</p> <p>rev / dir</p> <p>0 : REV (REVERSE) 1 : DIR (DIRECT)</p>	<p>1 (DIRECT)</p>	<p>Device Supports Dual Retransmission Output.</p>
<p>OP.T (op.t)</p>	<p>Output Type</p>	<p>Output Type</p> <p>rely / ssr/ lin</p> <p>0 : RELY (Relay) 1 : SSR (Voltage Pulse Output) 2 : LIN (Linear)</p> <p>Device can support RELAY or SSR output once at a time. (Factory Settable)</p>	<p>0 (Relay)</p>	<p>LIN option will not appear if C.OP.T(Control Type) is ON- OFF</p>

C.OP.T (c.op.t)	Control Output Type	Select Controlling Type for Output P / Pi / pid/ onof 0 : P (Proportional Control) 1 : PI 2 : PID 3 : ON-OFF	0 (P Type)	ON-OFF option will not appear if OP.T(Output Type) is LIN(Linear)												
A1.TP (a1.tp)	Alarm Type - 1	Refer ALARM Type Table on Page.44 0 to 15	0 (None)	Output Type is LIN(Linear)												
A2.TP (a2.tp)	Alarm Type - 2	Refer ALARM Type Table on Page.44 0 to 15	0 (None)													
A1.HY (a1.hy)	Alarm 1 Hysteresis	Set Hysteresis(in °C) for Alarm-1 <table border="1" data-bbox="507 772 1077 985"> <tr><td>1 to 100</td><td>TC & RTD Input</td></tr> <tr><td>0.1 to 100.0</td><td>RTD.1 Input</td></tr> <tr><td>1 to 100</td><td>Linear Input with DP=0</td></tr> <tr><td>0.1 to 100.0</td><td>Linear Input with DP=1</td></tr> <tr><td>0.01 to 10.00</td><td>Linear Input with DP=2</td></tr> <tr><td>0.001 to 1.000</td><td>Linear Input with DP=3</td></tr> </table>	1 to 100	TC & RTD Input	0.1 to 100.0	RTD.1 Input	1 to 100	Linear Input with DP=0	0.1 to 100.0	Linear Input with DP=1	0.01 to 10.00	Linear Input with DP=2	0.001 to 1.000	Linear Input with DP=3	2	Output Type is LIN(Linear)
1 to 100	TC & RTD Input															
0.1 to 100.0	RTD.1 Input															
1 to 100	Linear Input with DP=0															
0.1 to 100.0	Linear Input with DP=1															
0.01 to 10.00	Linear Input with DP=2															
0.001 to 1.000	Linear Input with DP=3															
A2.HY (a2.hy)	Alarm 2 Hysteresis	Set Hysteresis(in °C) for Alarm-2 <table border="1" data-bbox="507 1052 1077 1265"> <tr><td>1 to 100</td><td>TC & RTD Input</td></tr> <tr><td>0.1 to 100.0</td><td>RTD.1 Input</td></tr> <tr><td>1 to 100</td><td>Linear Input with DP=0</td></tr> <tr><td>0.1 to 100.0</td><td>Linear Input with DP=1</td></tr> <tr><td>0.01 to 10.00</td><td>Linear Input with DP=2</td></tr> <tr><td>0.001 to 1.000</td><td>Linear Input with DP=3</td></tr> </table>	1 to 100	TC & RTD Input	0.1 to 100.0	RTD.1 Input	1 to 100	Linear Input with DP=0	0.1 to 100.0	Linear Input with DP=1	0.01 to 10.00	Linear Input with DP=2	0.001 to 1.000	Linear Input with DP=3	2	
1 to 100	TC & RTD Input															
0.1 to 100.0	RTD.1 Input															
1 to 100	Linear Input with DP=0															
0.1 to 100.0	Linear Input with DP=1															
0.01 to 10.00	Linear Input with DP=2															
0.001 to 1.000	Linear Input with DP=3															
A1.LC (a1.lc)	Alarm 1 Logic	Set Logic for Alarm-1 norm / flsf 0 : NORM (Normal) 1 : FLSF (Fail-Safe) Page. 45 shows operation diagram of different alarm Type for Alarm Logic NORM(Normal). For Fail-Safe Logic Alarm will work completely opposite to Normal behavior. (i.e. for any particular condition when Relay is ON for Normal logic, for that condition relay will OFF for Fail-Safe Logic & vice-versa)	0 (Normal)	Output Type is LIN(Linear)												
A2.LC (a2.lc)	Alarm 2 Logic	Set Logic for Alarm-2 norm / flsf 0 : NORM (Normal) 1 : FLSF (Fail-Safe)	0 (Normal)													

A1.DY (a1.dy)	Alarm 1 Delay	Alarm Delay is amount of time (in sec), that Relay-1 will wait before getting ON after the alarm condition occurs. 1 to 99 sec	1	Output Type is LIN(Linear)
A2.DY (a2.Dy)	Alarm 2 Delay	Alarm Delay is amount of time (in sec), that Relay-2 will wait before getting ON after the alarm condition occurs. 1 to 99 sec	1	
A.CJC (a.cJC)	Auto Cold Junction Compensation	Select Auto Cold Junction Compensation required or not for TC input Type. no / yes 0 : NO 1 : YES	1 (YES)	Input Type is TC
F.CJC (F.cJC)	Fix cold junction Compensation	Set Fix cold junction Compensation value. 0 to 60.0 °C	0.0	Input Type is TC & A.CJC is NO
VER (ver)	Version	Shows the Version of the Current Firmware	-	
PASS (pass)	Password	Set Device Password 0 to 9999	1	

6.5 CALIBRATION MODE

CALIBRATION PARAMETERS				
Parameter (PV display)		Setting Name & Description	Default Value	Show if Only
Symbol	Name			
AMB (Amb)	Ambient	Ambient Adjustment	-	Input is TC
ZERO (zero)	ZERO	Calibration Zero for PV Input (SV Display : PV)	-	
SPAN (span)	SPAN	Calibration Span for PV Input (SV Display : PV)	-	
RT.1.Z (rt.1.z)	Retransmission-1 ZERO	Calibration Zero for Retransmission Output-1 (SV Display : If voltage: 0.000 If Current: 4.000)	-	Device Supports Retransmission Output

<p>RT.1.S (rt.1.s)</p>	<p>Retransmission-1 SPAN</p>	<p>Calibration Span for Retransmission Output-1 (SV Display : If voltage: 8.000 If Current: 20.00)</p>	<p>-</p>	<p>Device Supports Retransmission Output</p>
<p>RT.2.Z (rt.2.z)</p>	<p>Retransmission-2 ZERO</p>	<p>Calibration Zero for Retransmission Output 2 (SV Display : If voltage: 0.000 If Current: 4.000)</p>	<p>-</p>	<p>Device Supports Dual Retransmission Output</p>
<p>RT.2.S (rt.2.s)</p>	<p>Retransmission-2 SPAN</p>	<p>Calibration Span for Retransmission Output-2 (SV Display : If voltage: 8.000 If Current: 20.00)</p>	<p>-</p>	<p>Device Supports Dual Retransmission Output</p>

NOTE:-

- The retransmission output type is jumper selectable. Thus if current type or voltage type output, will be decided by the position of the jumper.
- **The Linear type control output will depend on the type of Retransmission-1 output selection.** If Retransmission-1 type output is 4-20mA, then the linear output will function respectively.
- No need to feed input while calibrating Rx. o/p. just make the value in calibration mode equal to the displayed value.

Example: How to Change Input Type?

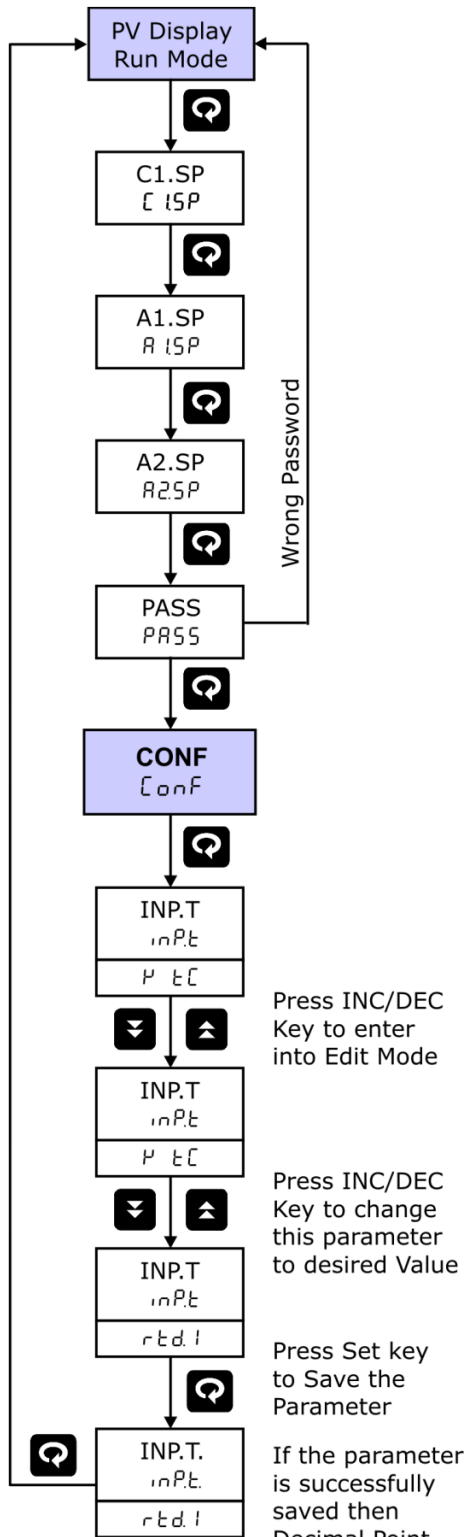

Press & Hold Set Key for few Seconds at any time to exit from Menu Mode & Come to Run Mode

Press INC/DEC Key to enter into Edit Mode

Press INC/DEC Key to change this parameter to desired Value

Press Set key to Save the Parameter

If the parameter is successfully saved then Decimal Point of the Right Most Digit will be ON.

7.MENU LAYOUT for LC5296-XP

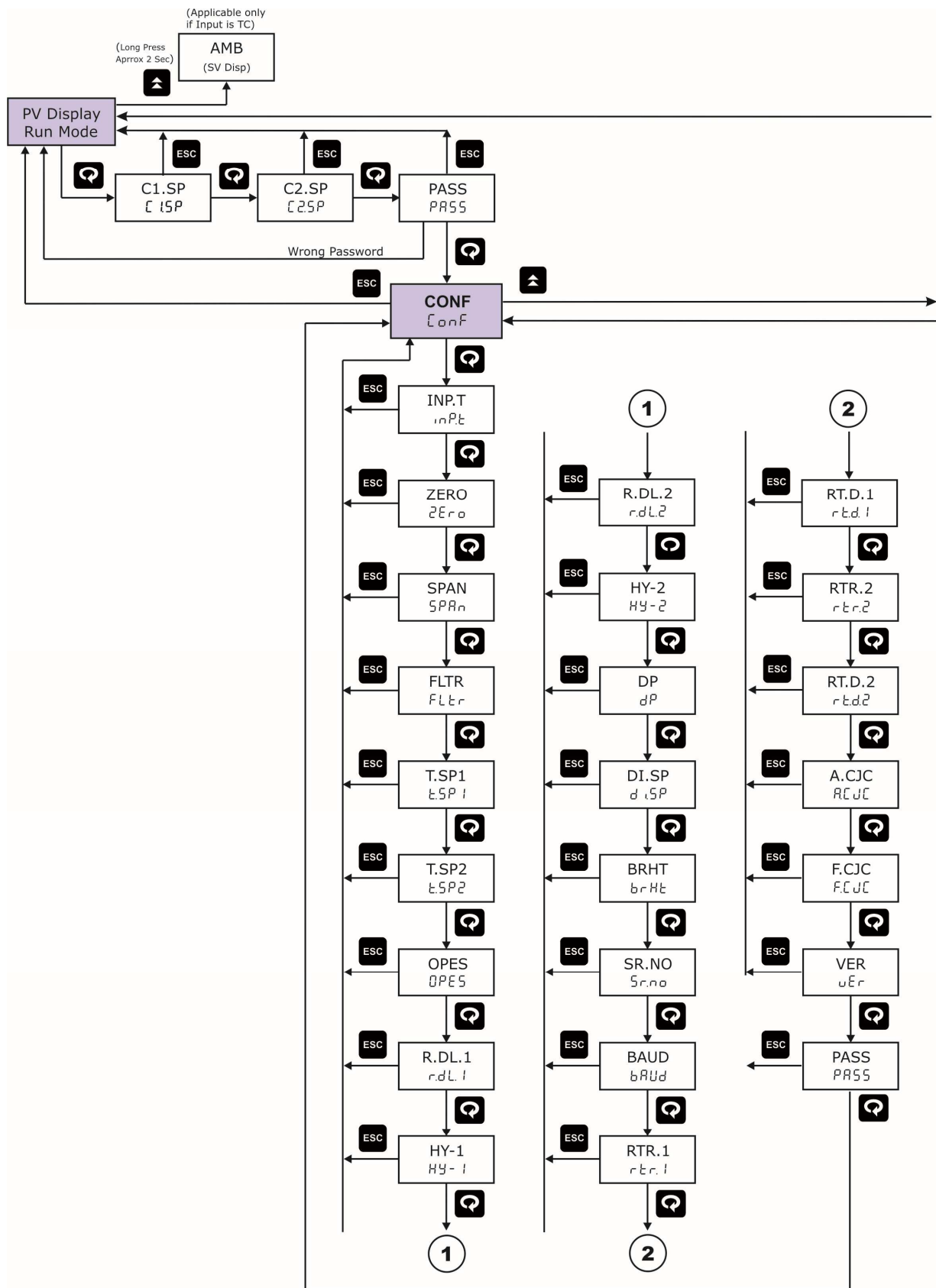

MENU LAYOUT for LC5296-XP

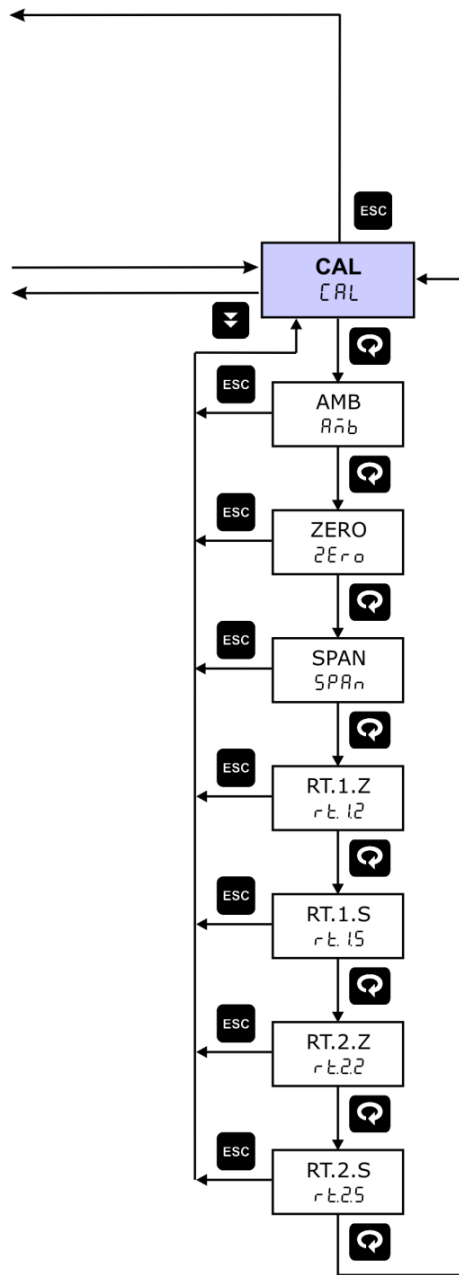

7.1 RUN Time Indication/Function

Following parameters can view or change during run time.

- For Thermocouple input type, Press Increment key to show ambient temperature.

7.2 Set Point Setting

Pressing SET key PV Display shows **c1.sp** (C1.SP) message. SV display shows **ControlSet Point-1 Value**. Use Inc and Dec key to modify value. OR press MENU key again to set value for **ControlSet Point-2 Value**.

Set Point Setting:				
Parameter (PV display)		Setting name and description	Default value	Shows only if
Symbol	Name			
C1.SP (c1.sp)	Control Set Point 1	Range Depending on PV sensor type selected	100	-
C2.SP (c2.sp)	Control Set Point 2	Range Depending on PV sensor type selected	200	-

7.3 CONFIGURATION MODE

CONFIGURATION PARAMETERS																																							
Parameter (PV display)		Setting Name & Description	Default Value	Show if Only																																			
Symbol	Name																																						
INP.T (inp.t)	INPUT Type	Set PV Input Type tC e / tC j / tC K / tC t / tC b / tC r / tC s / rtd.1 / rtd/ 0-5v / 1-5v	TC E																																				
		<table border="1"> <thead> <tr> <th>Value</th> <th>Input Type</th> <th>Range</th> </tr> </thead> <tbody> <tr> <td>0</td> <td>TC E</td> <td>-200 to 1000 °C</td> </tr> <tr> <td>1</td> <td>TC J</td> <td>-200 to 1200 °C</td> </tr> <tr> <td>2</td> <td>TC K</td> <td>-200 to 1372 °C</td> </tr> <tr> <td>3</td> <td>TC T</td> <td>-100 to 400 °C</td> </tr> <tr> <td>4</td> <td>TC B</td> <td>450 to 1800 °C</td> </tr> <tr> <td>5</td> <td>TC R</td> <td>0 to 1768 °C</td> </tr> <tr> <td>6</td> <td>TC S</td> <td>0 to 1768 °C</td> </tr> <tr> <td>7</td> <td>RTD.1</td> <td>-199.9 to 850.0 °C</td> </tr> <tr> <td>8</td> <td>RTD</td> <td>-200 to 850 °C</td> </tr> <tr> <td>9</td> <td>0-5 V / 0-20 mA*</td> <td rowspan="2">-1999 to 1999</td> </tr> <tr> <td>10</td> <td>1-5 V / 4- 20 mA*</td> </tr> </tbody> </table>			Value	Input Type	Range	0	TC E	-200 to 1000 °C	1	TC J	-200 to 1200 °C	2	TC K	-200 to 1372 °C	3	TC T	-100 to 400 °C	4	TC B	450 to 1800 °C	5	TC R	0 to 1768 °C	6	TC S	0 to 1768 °C	7	RTD.1	-199.9 to 850.0 °C	8	RTD	-200 to 850 °C	9	0-5 V / 0-20 mA*	-1999 to 1999	10	1-5 V / 4- 20 mA*
		Value			Input Type	Range																																	
		0			TC E	-200 to 1000 °C																																	
		1			TC J	-200 to 1200 °C																																	
		2			TC K	-200 to 1372 °C																																	
		3			TC T	-100 to 400 °C																																	
		4			TC B	450 to 1800 °C																																	
		5			TC R	0 to 1768 °C																																	
		6			TC S	0 to 1768 °C																																	
		7			RTD.1	-199.9 to 850.0 °C																																	
8	RTD	-200 to 850 °C																																					
9	0-5 V / 0-20 mA*	-1999 to 1999																																					
10	1-5 V / 4- 20 mA*																																						
		*Use external 250ohms,0.1% for current input																																					

ZERO (zero)	Zero	Automatically change to the Input Lower Range with changing of Input Type (Refer Above Table) Can be set to any value within the Input Range & less the SPAN Value.	-200 (If TC E)													
SPAN (span)	Span	Automatically change to the Input Higher Range with changing of Input Type (Refer Above Table) Can be set to any value within the Input Range & greater the ZERO Value.	1000 (If TC E)													
FLTR (fltr)	Filter	Filter for PV Input no / yes 0 : NO 1 : YES	1 (YES)													
T.SP1 (t.sp1)	Type of Set Point (Control Set Point-1) (Relay-1)	Set Type of Set Point 1 l-on / H-on 0 : L-ON (Lower ON) 1 : H-ON (Higher ON) Refer ON-OFF Control on Page:40	0 (L-ON)													
T.SP2 (t.sp2)	Type of Set Point (Control Set Point-2) (Relay-2)	Set Type of Set Point 2 l-on / H-on 0 : L-ON (Lower ON) 1 : H-ON (Higher ON) Refer ON-OFF Control on Page:40	0 (L-ON)													
OPES (opes)	OPEN Sensor Status	Set Control O/P & Retransmission state when Input OPEN condition. down / up 0 : DOWN 1 : UP	0 (DOWN)													
R.DL.1 (r.dl.1)	Relay Delay (For Relay-1)	Relay Delay is amount of time (in sec), that Relay 1 will wait before getting ON after the ON condition occurs. 1 to 99 sec	1 sec													
HY-1 (Hy-1)	Hysteresis – 1 (For Relay-1)	Hysteresis Value (in °C) for Relay-1 <table border="1" data-bbox="507 1814 1078 2024"> <tr> <td>1 to 100</td> <td>TC & RTD Input</td> </tr> <tr> <td>0.1 to 100.0</td> <td>RTD.1 Input</td> </tr> <tr> <td>1 to 100</td> <td>Linear Input with DP=0</td> </tr> <tr> <td>0.1 to 100.0</td> <td>Linear Input with DP=1</td> </tr> <tr> <td>0.01 to 10.00</td> <td>Linear Input with DP=2</td> </tr> <tr> <td>0.001 to 1.000</td> <td>Linear Input with DP=3</td> </tr> </table>	1 to 100	TC & RTD Input	0.1 to 100.0	RTD.1 Input	1 to 100	Linear Input with DP=0	0.1 to 100.0	Linear Input with DP=1	0.01 to 10.00	Linear Input with DP=2	0.001 to 1.000	Linear Input with DP=3	5	
1 to 100	TC & RTD Input															
0.1 to 100.0	RTD.1 Input															
1 to 100	Linear Input with DP=0															
0.1 to 100.0	Linear Input with DP=1															
0.01 to 10.00	Linear Input with DP=2															
0.001 to 1.000	Linear Input with DP=3															

R.DL.2 (<i>r.dl.2</i>)	Relay Delay (For Relay-2)	Relay Delay is amount of time (in sec), that Relay 2 will wait before getting ON after the ON condition occurs. 1 to 99 sec	1 sec													
HY-2 (<i>Hy-2</i>)	Hysteresis – 2 (For Relay-2)	Hysteresis Value (in °C) for Relay-2 <table border="1"> <tr> <td>1 to 100</td> <td>TC & RTD Input</td> </tr> <tr> <td>0.1 to 100.0</td> <td>RTD.1 Input</td> </tr> <tr> <td>1 to 100</td> <td>Linear Input with DP=0</td> </tr> <tr> <td>0.1 to 100.0</td> <td>Linear Input with DP=1</td> </tr> <tr> <td>0.01 to 10.00</td> <td>Linear Input with DP=2</td> </tr> <tr> <td>0.001 to 1.000</td> <td>Linear Input with DP=3</td> </tr> </table>	1 to 100	TC & RTD Input	0.1 to 100.0	RTD.1 Input	1 to 100	Linear Input with DP=0	0.1 to 100.0	Linear Input with DP=1	0.01 to 10.00	Linear Input with DP=2	0.001 to 1.000	Linear Input with DP=3	5	
1 to 100	TC & RTD Input															
0.1 to 100.0	RTD.1 Input															
1 to 100	Linear Input with DP=0															
0.1 to 100.0	Linear Input with DP=1															
0.01 to 10.00	Linear Input with DP=2															
0.001 to 1.000	Linear Input with DP=3															
DP (<i>dp</i>)	Decimal Point	Set position of Decimal Point on Display. 0 / 0.0 / 0.00 / 0.000 0 : 0 1 : 0.0 2 : 0.00 3 : 0.000	0	Input Type is Linear												
DI.SP (<i>di.sp</i>)	Display Set Point	Set which Set Point to shown in SV display in RUN mode while device is in Auto Mode <i>C1.sp / C2.sp</i> 0 : C1.SP (Control Set Point 1) 1 : C2.SP (Control Set Point 2)	0													
BRHT (<i>brHt</i>)	Brightness	Adjust Brightness of the 7-segment Display. 10 to 100	50													
SR.NO (<i>sr.no</i>)	Serial No.	Unit ID for Modbus-RS485 Communication 1 to 247	1	Device supports RS485 Communication.												
BAUD (<i>baud</i>)	Baud Rate	Set Modbus RS485 Communication Baud Rate 9600 / 19.2k / 38.4k 0 : 9600 (9600 bps) 1 : 19.2K (19200 bps) 2 : 38.4K (38400 bps)	0 (9600)	Device supports RS485 Communication.												

<p>RTR.1 (rtr.1)</p>	<p>Retransmission 1 Type</p>	<p>Retransmission-1 Output Type This output is according to PV input. Zero & Span acts as Min & Max value of retransmission o/p scale respectively.</p> <p>0-5v / 1-5v / 0-10v / 4-20 / 0-20</p> <p>0 : 0-5V 1 : 1-5V 2 : 0-10V 3 : 4-20mA 4 : 0-20mA</p> <p>Voltage or Current is Jumper Selectable from the Hardware.</p>	<p>3 (4-20mA)</p>	<p>Device Supports Retransmission Output.</p>
<p>RT.D.1 (rt.d.1)</p>	<p>Retransmission -1 Direction</p>	<p>Set Direction for the Retransmission Output-1</p> <p>rev / dir</p> <p>0 : REV (REVERSE) 1 : DIR (DIRECT)</p> <p>EX. If i/p is RTD.1, ZERO=0, SPAN=600, RTR.1=4-20mA &</p> <p>RT.D.1=DIR when PV = 0, RTR o/p = 4mA PV = 300, RTR o/p = 12mA PV = 600, RTR o/p = 20mA</p> <p>RT.D.1=REV when PV = 0, RTR o/p = 20mA PV = 300, RTR o/p = 12mA PV = 600, RTR o/p = 4mA</p> <p>Refer Retransmission o/p table on Page 53 for more info.</p>	<p>1 (DIRECT)</p>	<p>Device Supports Retransmission Output.</p>
<p>RTR.2 (rtr.2)</p>	<p>Retransmission 2 Type</p>	<p>Retransmission-2 Output Type This output is according to PV input. Zero & Span acts as Min & Max value of retransmission o/p scale respectively.</p> <p>0-5v / 1-5v / 0-10v / 4-20 / 0-20</p> <p>0 : 0-5V 1 : 1-5V 2 : 0-10V 3 : 4-20mA 4 : 0-20mA</p> <p>Voltage or Current is Jumper Selectable from the Hardware.</p>	<p>3 (4-20mA)</p>	<p>Device Supports Dual Retransmission Output.</p>

RT.D.2 (rt.d.2)	Retransmission -2 Direction	Set Direction for the Retransmission Output-2 rev / dir 0 : REV (REVERSE) 1 : DIR (DIRECT)	1 (DIRECT)	Device Supports Dual Retransmission Output.
A.CJC (a.cjc)	Auto ColdJunction Compensation	Select Auto Cold Junction Compensation required or not for TC input Type. no / yes 0 : NO 1 : YES	1 (YES)	Input Type is TC
F.CJC (f.cjc)	Fix cold junction Compensation	Set Fix cold junction Compensation value. 0 to 60.0 °C	0.0	Input Type is TC & A.CJC is NO
VER (ver)	Version	Shows the Version of the Current Firmware	-	
PASS (pass)	Password	Set Device Password 0 to 9999	1	

7.4 CALIBRATION MODE

CALIBRATION PARAMETERS				
Parameter (PV display)		Setting Name & Description	Default Value	Show if Only
Symbol	Name			
AMB (Amb)	Ambient	Ambient Adjustment	-	Input is TC
ZERO (zero)	ZERO	Calibration Zero for PV Input (SV Display : PV)	-	
SPAN (span)	SPAN	Calibration Span for PV Input (SV Display : PV)	-	
RT.1.Z (rt.1.z)	Retransmission-1 ZERO	Calibration Zero for Retransmission Output-1 (SV Display : If voltage: 0.000 If Current: 4.000)	-	Device Supports Retransmission Output
RT.1.S (rt.1.s)	Retransmission-1 SPAN	Calibration Span for Retransmission Output-1 (SV Display : If voltage: 8.000 If Current: 20.00)	-	Device Supports Retransmission Output
RT.2.Z (rt.2.z)	Retransmission-2 ZERO	Calibration Zero for Retransmission Output 2 (SV Display : If voltage: 0.000 If Current: 4.000)	-	Device Supports Dual Retransmission Output

RT.2.S (rt.2.s)	Retransmission-2 SPAN	Calibration Span for Retransmission Output-2 (SV Display : If voltage: 8.000 If Current: 20.00)	-	Device Supports Dual Retransmission Output
---------------------------	--------------------------	--	---	--

NOTE:-

- The retransmission output type is jumper selectable. Thus if current type or voltage type output, will be decided by the position of the jumper.
- No need to feed input while calibrating Rx. o/p. just make the value in calibration mode equal to the displayed value.

Example:How to change Input Type?

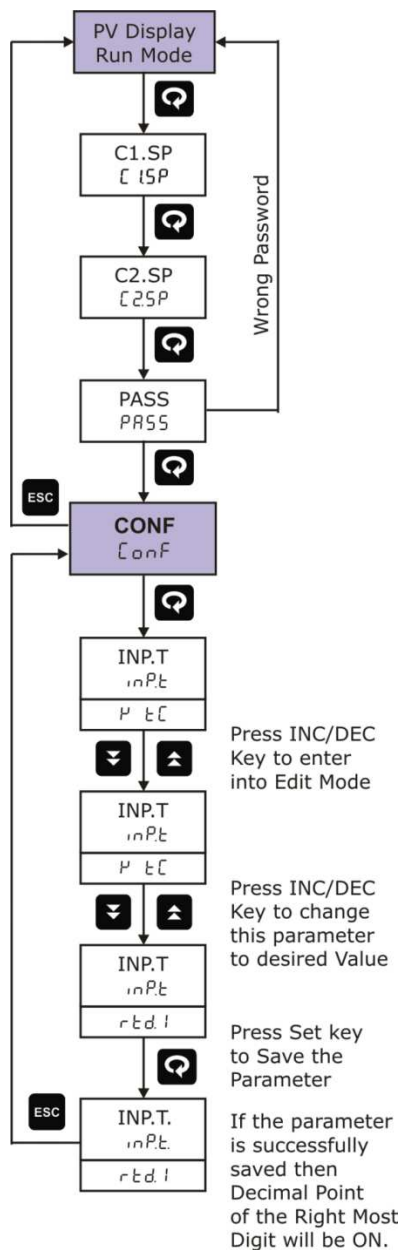

8. CONTROL FUNCTION

- Model LC5296-XP-AT is a microcontroller based PID controller & ON-OFF Controller.
- Model LC5296-XP is a microcontroller based ON-OFF Controller without PID controlling.

8.1 ON/OFF Control

ON/OFF Controller is the simplest form of temperature control device. The output from the device is either on or off, with no middle state. An on-off controller will switch the output only when the temperature crosses the setpoint. For heating control, the output is on when the temperature is below the set point, and off above set point.

Since the temperature crosses the set point to change the output stage, the process temperature will be cycling continually, going from below set point to above, and back below. In cases where this cycling occurs rapidly, and to prevent contactors and valves from getting damaged, an on-off differential, or “hysteresis,” is added to the controller operations. On-Off hysteresis prevents the output from “chattering” or making fast, continual switches if the cycling above and below the set point occurs very rapidly.

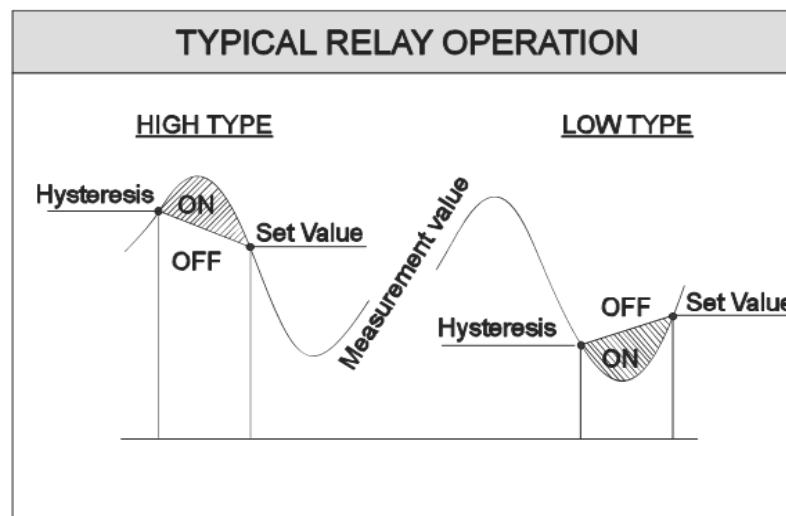

Figure 8.1: Typical Relay operation

High type (H-ON):

For High type of set value, once process value reaches up to set point + Hysteresis value, relay will be ON after few seconds (as per relay delay) and it will be ON until process value goes down to Set point.

Low type (L-ON):

For Low type of set value, once process value reaches down to set point – Hysteresis value relay will be ON after nearly few seconds (as per relay delay) and it will be ON until process value goes up toward Set point.

NOTE:-

- LC5296-XP is having only ON-OFF controlling so no need to do any additional setting.
- Whereas LC5296-XP-AT has both ON-OFF & PID Controlling. If ON-OFF controlling is required, C.OP.T (Control Type) must be selected as ON-OFF.
- For LC5296-XP-AT, ON-OFF control type is available for Relay & SSR output type only.
- In LC5296-XP-AT, when PB, TI, TD term is '0' and auto tune is set 'no', and unit is not in manual mode, then control output will work as on-off controller else it will work as PID controller.

8.2 PID Control

(LC5296-XP-AT Only)

AUTO TUNE FUNCTION:

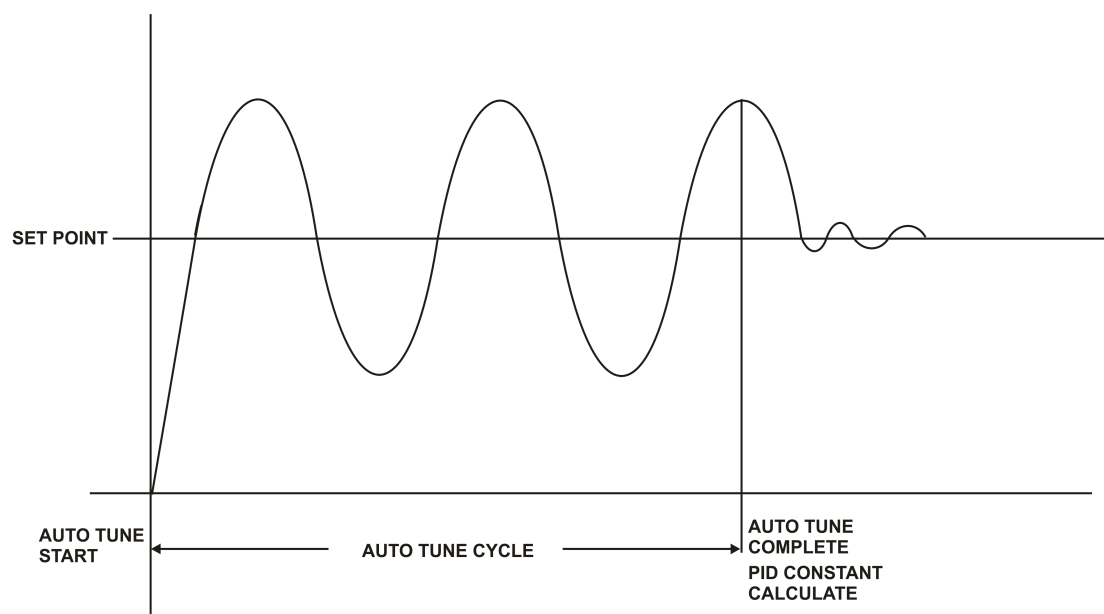

Auto Tuning:

The Auto tuning process is performed at set point. Temperature will oscillate around the set point during tuning process. Set a set point to a lower value if overshooting around the normal process value is likely to cause damage. To start the auto tuning process, set the desired set point, select the parameter AT in TUNE menu and set it to YES.

During Auto tuning lower display will flash AT (AUTO) message. After auto tune procedure is completed, the AT message will be removed and controller will revert back to the PID control by using the new calculated PID values. The PID values obtained are stored in the nonvolatile memory.

Control Parameter:-

Proportional BAND:

Proportional action is the action which the control output varies in proportion to the deviation between the setting value and the processing temperature. If the proportional band is narrowed, even if the output changes by a slight variation of the processing temperature, better control results can be obtained as the offset decreases. However, if when the proportional band is narrowed too much, even slight disturbances may cause variation in the processing temperature, and control action changes to ON/OFF action and the so called hunting phenomenon occurs. Therefore, when the processing temperature comes to a balanced position near the setting value and a constant temperature is maintained, the most suitable value is selected by gradually narrowing the proportional band while observing the control results.

Integral Time:

Integral action is used to eliminate offset. When the integral time is shortened, the returning speed to the setting point is quickened. However, the cycle of oscillation is also quickened and the control becomes unstable.

Derivative Time:

Derivative action is used to restore the change in the processing temperature according to the rate of change. It reduces the amplitude of overshoot and undershoots width. If the derivative time is shortened, restoring value becomes small, and if the derivative time is made longer, an excessive returning phenomenon may occur and the control system may be oscillated.

Manual Reset:

Virtually no process requires precisely 50% output on single output controls or 0% output on two output controls. Because of this many older control designs incorporated an adjustment called manual reset (also called offset on some controls). This adjustment allows the user to redefine the output requirement at the set point. A proportioning control without manual reset or Integral time (defined above) will settle out somewhere within the proportioning band but likely not on the set point.

Some controls use manual reset (as a digital user programmable value), this allows the user to preprogram the approximate output requirement at the set point to allow for quicker settling at set point when Automatic reset (Integral time) set to zero. Range for the manual reset is -50.0% to +50.0% of proportional band.

Cycle Time:

The Cycle time for output is the time where the output is on for percentage of that time and off for a percentage of that time, creating a portioning effect. The cycle time is only used where PI, PD or PID control action is used. The shorter the cycle time, the higher the proportionate resolution is, and better is the control.

For Relay output: Set to 10 to 300 seconds or more

For SSR output: Set to 1 to 60 seconds or more

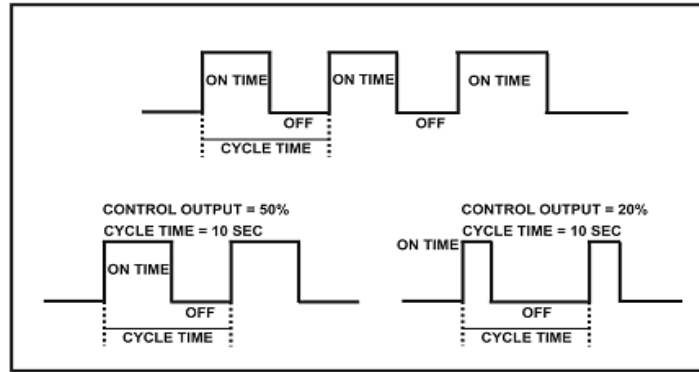

BASIC PID TUNING PROCEDURE:

ADJUSTMENT SEQUENCE	SYMPTOM	SOLUTION
Proportional Band	Slow Response	Decrease PB
	Overshoot or Oscillation	Increase PB
Integral Time	Slow Response	Decrease TI
	Instability or Oscillation	Increase TI
Derivative Time	Slow Response or Oscillation	Decrease TD
	High Overshoot or Instability	Increase TD

P ACTION: -

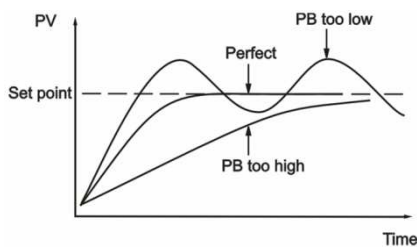

I Action: -

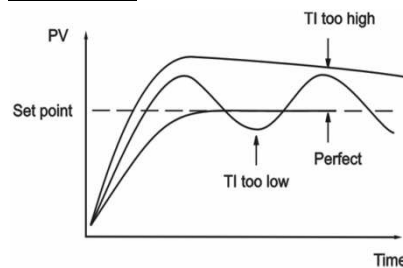

D Action: -

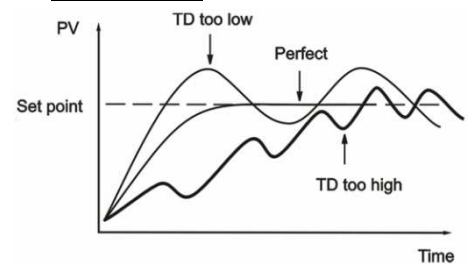

Control output Selection:

“C.OP.T”	“OP.T”	Terminal 4,5,6	Terminal 1,2,3	Terminal 15, 16	Terminal 17, 18
P/PI/PID	Relay	USE FOR CONTROL ACTION	ALARM2	AO output	AO Output/ Communication
	SSR	USE FOR CONTROL ACTION	ALARM2	AO output	AO Output/ Communication
	Linear	ALARM1	ALARM2	USE FOR CONTROL ACTION	AO Output/ Communication
ON-OFF Action	Relay	USE FOR CONTROL ON-OFF ACTION	ALARM2	AO output	AO Output/ Communication

NOTE:-At a time either Relay or SSR is provided(factory set)
 For Terminal 17, 18 only one is available (AO Output or Communication)

9. ALARM OUTPUT

Available Only for LC5296-XP-AT

For all Alarm outputs there are five settings. (As shown in configuration mode Menu)

- Set Value (in run mode)
- Type
- Hysteresis(Dead band)
- Direction (Normal/Fail safe)
- Delay

SET VALUE: Alarm set point

9.1 ALARM TYPES

Various alarm operations are shown in the reference figure.

ALARM TYPE NO	Display message	ALARM TYPE	Note
0	none	None	NO operation available
1	Pv.d.H	Deviation High alarm	Ref figure 3
2	Pv.d.L	Deviation Low alarm	Ref figure 4
3	Pv.d.r	Deviation High & Low range alarm	Ref figure 5
4	Pv.d.b	Deviation High & Low Band alarm	Ref figure 6
5	Pv.a.H	Absolute value High alarm	Ref figure 1
6	Pv.A.L	Absolute value Low alarm	Ref figure 2
7	SP.A.H	Absolute value set point high alarm	Ref figure 7
8	SP.A.L	Absolute value set point low alarm	Ref figure 8
9	P.S.d.H	Deviation High alarm with standby	Same as figure 3
10	P.S.d.L	Deviation Low alarm with standby	Same as figure 4
11	P.S.d.r	Deviation High & Low range alarm with standby	Same as figure 5
12	P.S.d.b	Deviation High & Low limit alarm with standby	Same as figure 6
13	P.S.A.H	Absolute value High alarm with standby	Same as figure 1
14	P.S.A.L	Absolute value Low alarm with standby	Same as figure 2
15	PV.-E.	PV error(OPEN/OVER/UNDER)	Note 1

NOTE-1:

The fault diagnosis output turns on in case of input burnout (PV) failure.

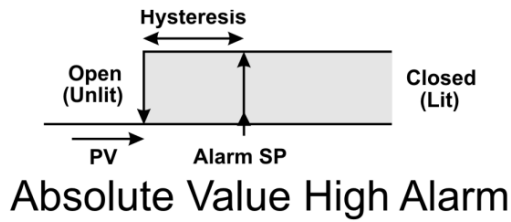

Figure: 1

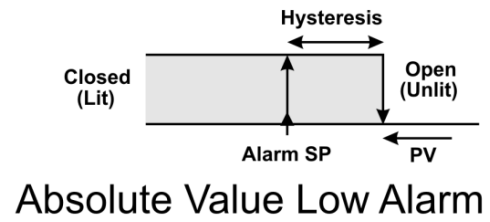

Figure: 2

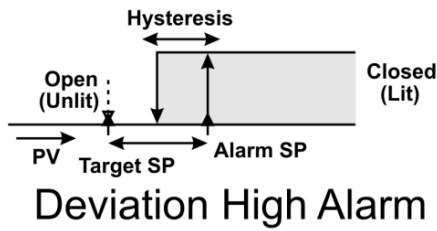

Figure: 3

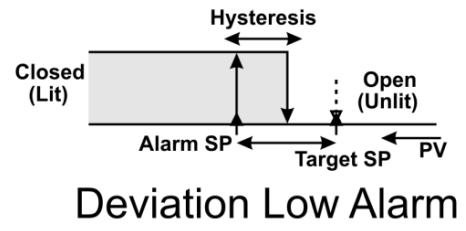

Figure: 4

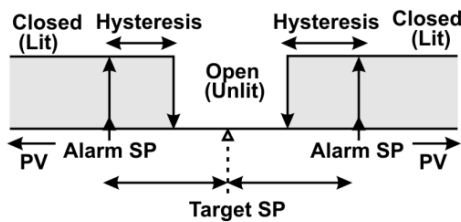

Figure: 5

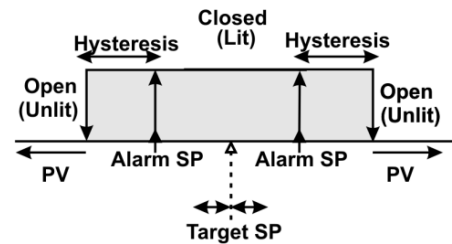

Figure: 6

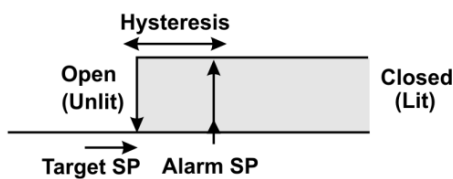

Figure: 7

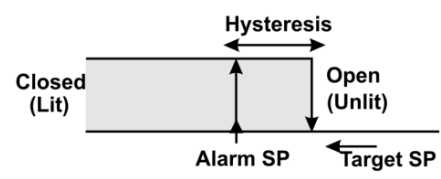

Figure: 8

NOTE:-

- LIT = LED on, UNLIT = LED off
- Up arrow indicate Alarm will ON from this value.
- Down arrow indicate Alarm will OFF from this value.

Hysteresis (Dead band): Hysteresis (Dead band) application is shown in the figure.

Direction:

All the figures here are shown considering the setting is direct (Normal). If the settings are reversing (Fail Safe), the relays will behave exactly the opposite. However, it's worth mentioning that the relays will be in off (de-energized state on Power on / reset condition). They will energize only after approximate 5 seconds. When alarm type none is selected, ALRAM relay status depends on Direction.

Delay:

A time delay can be provided for the actual output. The relay will operate after the set delay time.

Standby operation:

For alarm types, 9 to 14, the relay action happens only after the PV has crossed the SP after power on.

Example:-

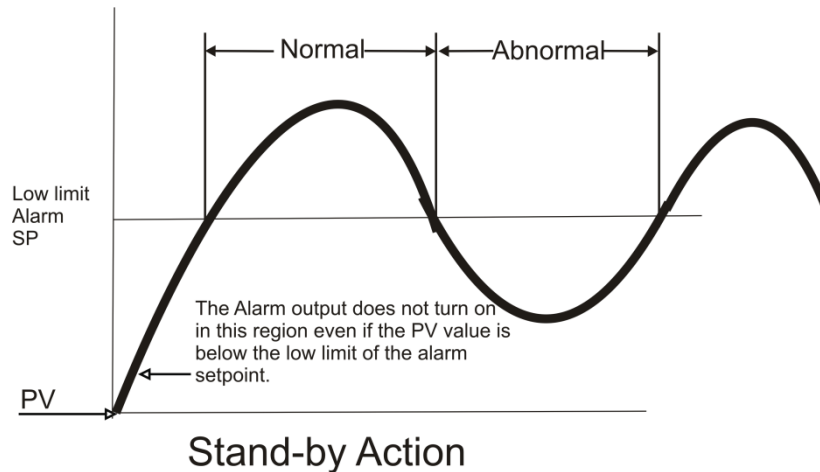

FIGURE 9.1. ALARM OUTPUT DIAGRAM

10. CALIBRATION PROCEDURE

10.1 Procedure for CAL-zero and CAL-span

The instrument is factory calibrated for the specified range, but due to long term drift of components, re-calibration may be necessary in some cases. For calibrating the instrument a reliable source is required. This source should be at least ten times accurate compared to the range of the instrument.

The unit can be calibrated without opening it and without trimpots. To enter in calibration mode press 'SET' key consecutively in Run mode until **PASS** message on the display. Now press 'INCREMENT KEY' to enter the correct password (Enter user's password if selected or enter factory default password: 1), after entering the correct password, **TUNE/CONF** message is displayed, now press 'INCREMENT KEY' to bring calibration mode. Invoking of Increment key will show **CAL** message. Now press 'SET', this will bring the first calibration parameter on display as **AMB.** (Ambient in case of T/C), in case of RTD or Linear Input it will show **CALZ.** (Zero calibration).

After applying appropriate Input from the calibrator source, press 'INCREMENT' OR 'DECREMENT KEY' to bring the actual process value on display.

Example:-

At zero calibration reading expected on the display is 100 and it shows 107, adjust the process value to 100 by using 'DECREMENT KEY'. Now press 'SET' to store the calibration parameter in non-volatile memory. Similarly one can calibrate Ambient, SPAN and retransmission parameters.

For calibrating i/p, both zero and span are calibrated. Here **one-shot calibration** technique is used, i.e. the zero and span are calibrated once. Individual zero or span can also be calibrated; first calibrate zero and then span. While calibrating thermocouple type input, first calibrate the ambient (if required) and then continue with the span calibration of the same.

10.2 Procedure for RET-zero and RET-span

For calibrating the retransmission output, both retransmission zero and retransmission span has to be calibrated. At a time there can be either one or two retransmission output available. If only one retransmission is used, then calibrate **RTZ1** (retransmission 1 zero) and **RTS1** (retransmission 1 span) and if there are two retransmission outputs available, then calibrate **RTZ2** (retransmission 2 zero) and **RTS2** (retransmission 2 span) for second retransmission. No need to feed input while calibrating retransmission o/p. it is like calibrating using digital trim pot. Only look at the output, display value has no significance with output generated.

Example:-

At retransmission zero calibration, expected output is 4.00mA and it gives 4.153mA. Then adjust the output value to 4.153 by using 'INCREMENT KEY'. Now press 'SET1' to store the calibration parameter in non-volatile memory. Similarly one can calibrate retransmission span.

11. COMMUNICATION PROTOCOL–MODBUS RTU

11.1 INTRODUCTION

The unit can be connected in RS-485 communication data link either in multi drop or repeat mode. Each unit must have unique Serial Number. Entire range of addresses (1 to 247) may be used. Before starting any communication, choose a baud rate compatible to the host computer. The serial protocol used is MODBUS RTU.

Function Code for Modbus

CODE	NAME	Function
01	Read coil status	Use to read Relay and Digital output status
03	Read Holding registers	Use to read PV, Control, RSP output etc
04	Read input registers	Use to read programmable registers
06	Preset Single register	Use to write programmable register

The error checking field contains a 16-bit value implemented as two eight-bit bytes. The error check value is the result of a Cyclical Redundancy Check (CRC) calculation performed on the message contents.

11.2 Modbus Parameter Address

Sr. No.	Parameters	Absolute Address	Type	Access Type	LC5296-XP-AT	LC5296-XP
1	PROCESS VALUE	30001	Int	Read Only	✓	✓
2	POWER IN PERCENTAGE	30002	Int	Read Only	✓	✗
3	AUTOTUNE STATUS	30003	Int	Read Only	✓	✗
4	AMBIENT	30004	Int	Read Only	✓	✓
5	SSR STATUS	30005	Int	Read Only	✓	✗
6	RELAY-1 STATUS	30006	Int	Read Only	✓	✓
7	RELAY-2 STATUS	30007	Int	Read Only	✓	✓

NOTE:Process Value (PV) Error Conditions Value

OPEN : 32767
 UNDER : 32765
 OVER : 32766

Sr. No.	Parameters	Absolute Address	Type	Access Type	LC5296-XP-AT	LC5296-XP
1	Input Type	40001	Int	R + W	✓	✓
2	Zero	40002	Int	R + W	✓	✓
3	Span	40003	Int	R + W	✓	✓
4	Filter	40004	Int	R + W	✓	✓
5	SET Type-1	40005	Int	R + W	✓	✓
6	SET Type-2	40006	Int	R + W	✗	✓

7	Open Sensor Status	40007	Int	R + W	✓	✓
8	Relay Delay -1	40008	Int	R + W	✓	✓
9	Hysteresis 1	40009	Int	R + W	✓	✓
10	Relay Delay -2	40010	Int	R + W	✗	✓
11	Hysteresis 2	40011	Int	R + W	✗	✓
12	Decimal Point	40012	Int	R + W	✓	✓
13	Display set point	40013	Int	R + W	✓	✓
14	Brightness	40014	Int	R + W	✓	✓
15	Serial Number	40015	Int	R + W	✓	✓
16	Baud Rate	40016	Int	R + W	✓	✓
17	Retransmission o/p Type -1	40017	Int	R + W	✓	✓
18	Retransmission o/p direction - 1	40018	Int	R + W	✓	✓
19	Retransmission o/p Type -2	40019	Int	R + W	✓	✓
20	Retransmission o/p direction - 2	40020	Int	R + W	✓	✓
21	Control output type	40021	Int	R + W	✓	✗
22	Control type	40022	Int	R + W	✓	✗
23	Alarm-1 Type	40023	Int	R + W	✓	✗
24	Alarm- 2 Type	40024	Int	R + W	✓	✗
25	Alarm-1 hysteresis	40025	Int	R + W	✓	✗
26	Alarm-2 hysteresis	40026	Int	R + W	✓	✗
27	Alarm-1 logic	40027	Int	R + W	✓	✗
28	Alarm-2 logic	40028	Int	R + W	✓	✗
29	Alarm-1 delay	40029	Int	R + W	✓	✗
30	Alarm-2 delay	40030	Int	R + W	✓	✗
31	Auto CJC	40031	Int	R + W	✓	✓
32	Fixed CJC	40032	Int	R + W	✓	✓
33	Version	40033	Int	R	✓	✓
34	Password	40034	Int	R + W	✓	✓
35	Control set point-1	40035	Int	R + W	✓	✓
36	Alarm Set Point-1 Control Set Point-2 (Refer Note-1)	40036	Int	R + W	✓	✓
37	Set Value 2	40037	Int	R + W	✓	✗
38	Proportional band	40038	Int	R + W	✓	✗
39	Integral time	40039	Int	R + W	✓	✗
40	Derivative time	40040	Int	R + W	✓	✗
41	Cycle time	40041	Int	R + W	✓	✗
42	Output Direction	40042	Int	R + W	✓	✗

43	Manual reset	40043	Int	R + W	✓	✗
44	Sampling rate	40044	Int	R + W	✓	✗
45	Sampling period	40045	Int	R + W	✓	✗
46	%POWER	40046	Int	R + W	✓	✗
47	Auto/Manual	40047	Int	R + W	✓	✗

11.3 Exceptional Response

CODE	MEANING
01	Function code Invalid. It must be 01, 05, 03 or 06. The function code received in the query is not allowable action for the slave.
02	Illegal address value. The data address received in the query is not an allowable address for the slave.
03	Illegal data value. A value contained in the query data field is not an allowable value for the slave.
06	When Master device write some parameters to Slave device, If slave device busy then it will send 06 code to indicate slave device is busy.

Note:

- For Model LC5296-XP-AT address 40035 refer to Alarm Set Point-1
For Model LC5296-XP address 40035 refer to Control Set Point-2
- ✓ : Available for this Model.
✗ : Not Available for this Model.
- Any Parameter which is not available for the Model, the value at its address will be “0”. And it is Not Writable.
- If Some parameters are blocked in the Menu due to particular Configuration Settings, value at their respective address will be “0”. And these are Not Writable.

(EX: If device’s Input type is currently RTD.1, so DP (Decimal Point) parameter will not available in the Menu. So at its Address (40011) value will be “0” & it can’t changeable.)

- Refer Menu Mode Description Table the value & Range of each Parameter.

EX: Input Type (Applicable Range : 0 to 10):

Input Type	Value
E-tc	0
J-tc	1

K-tc	2
T-tc	3
B-tc	4
R-tc	5
S-tc	6
RTD 0.1 degree	7
RTD 1 degree	8
0 – 5V	9
1 – 5V	10

12. Appendix

12.1 Troubleshooting

If the operating display does not appear after turning on the controller's power, follow the measures in the procedure below.

If a problem appears complicated, contact our sales representative.

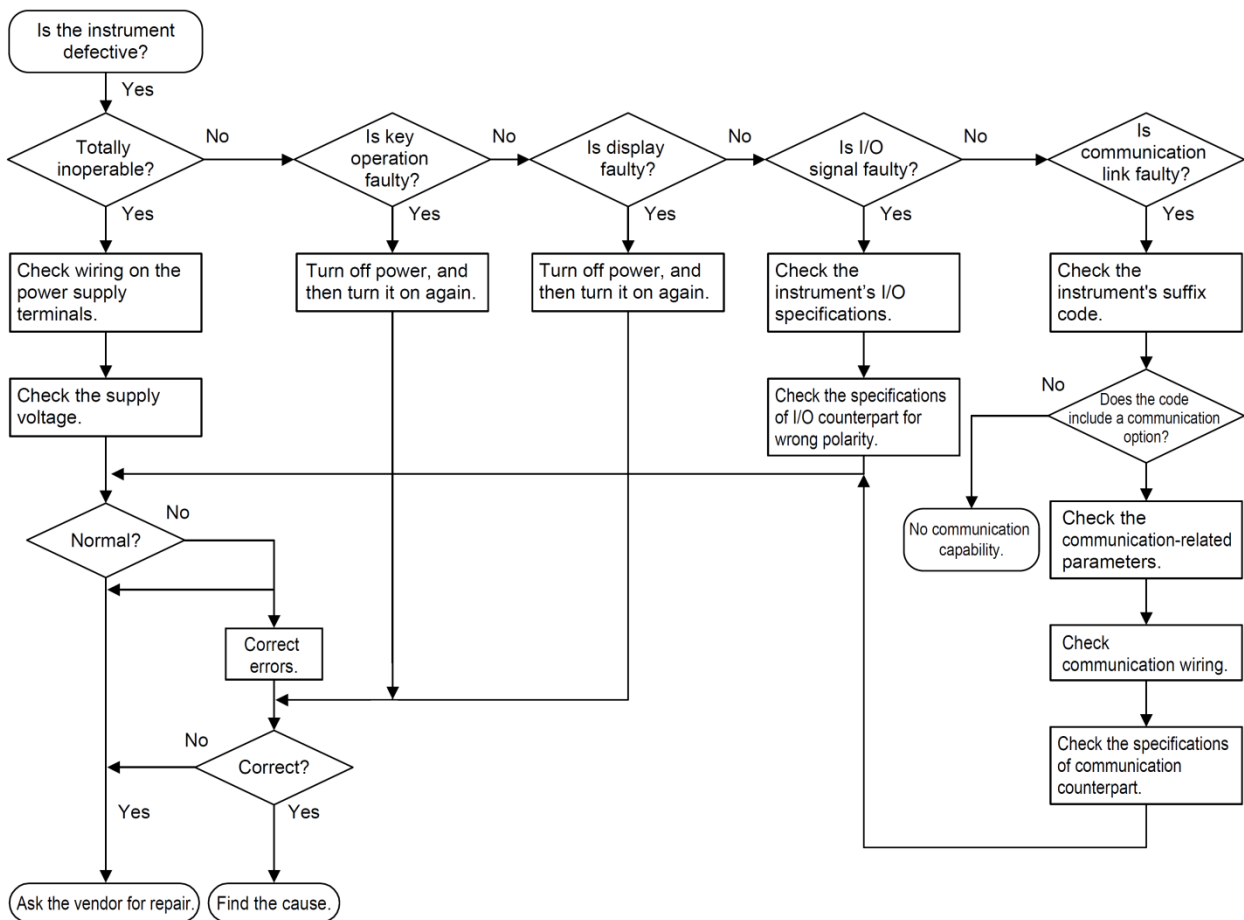

IMPORTANT

Take note of the parameter settings when asking the vendor for repair.

12.2 ON-OFF LOGIC

Relay type	PV	Relay	LED
Hi-On	PV > SP	On	On
	PV < SP	Off	Off
Open sensor	Up scale	On	On
	Down scale	Off	Off
Low-On	PV > SP	Off	Off
	PV < SP	On	On
Open sensor	Up scale	Off	Off
	Down scale	On	On

12.3 RETRANSMISSION OUTPUT TABLE FOR OPEN /OVER /UNDER CONDITION

RETRASMISSION	VARIABLE	SCALE	ACTION	OPEN	OVER	UNDER
4-20mA	PV	UP	DIR	20.8	20.8	3.2
	PV	DOWN	REV	3.2	3.2	20.8
	PV	UP	REV	20.8	3.2	20.8
	PV	DOWN	DIR	3.2	20.8	3.2
	PV	UP	DIR	5.2V	5.2V	0.8V
1-5V	PV	DOWN	REV	0.8V	0.8V	5.2V
	PV	UP	REV	5.2V	0.8V	5.2V
	PV	DOWN	DIR	0.8V	5.2V	0.8V

NOTE: -

1. OPEN/UNDER/OVER condition is applicable to all input types except 0-5v / 0-20mA.

12.4 Control Output Table for OPEN/OVER/ UNDER Condition

CONTROL OP	Process Scale	Output Direction (O.DIR)	DISPLAY INDICATION		
			OPEN	OVER	UNDER
4-20mamp Current	UP	DIR	20.0	20.0	4.0
	DOWN	REV	4.0	4.0	20.0
	UP	REV	20.0	4.0	20.0
	DOWN	DIR	4.0	20.0	4.0
SSR Pulse Output	UP	DIR	ON	ON	OFF
	DOWN	REV	OFF	OFF	ON
	UP	REV	ON	OFF	ON
	DOWN	DIR	OFF	ON	OFF
RELAY	UP	DIR	ON	ON	OFF
	DOWN	REV	OFF	OFF	ON
	UP	REV	ON	OFF	ON
	DOWN	DIR	OFF	ON	OFF

12.5 Jumper Settings for Addon Card Selection & Retransmission Output Type

- These devices come with different Variants differing by various Output option available.
- There are Two Addon Card Slots available on PCB of Signal Card. The Right Most Slot is fixed for Retransmission (Analog) Output. And the other Left Slot can be used for either Retransmission or RS-485 Communication Card by appropriate Jumper setting shown in below figure.
- 0E (SMD 0805) Resistor is used for shorting the Jumper.
- Jumper Setting for ADDON Card (Retransmission or Communication)
 - For **Communication** short pin 2 & 3 of Jumpers J3, J4, J5, J6, J7, J8, J10 using 0E Resistor in Display Card.

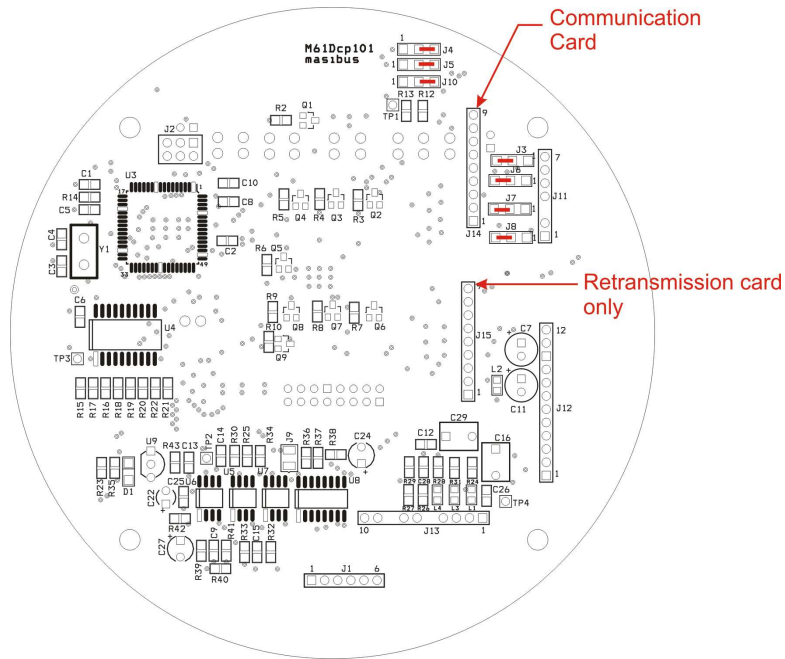

- For **Retransmission** short pin 1 & 2 of Jumpers J3, J4, J5, J6, J7, J8, J10 using 0E Resistor in Display Card.

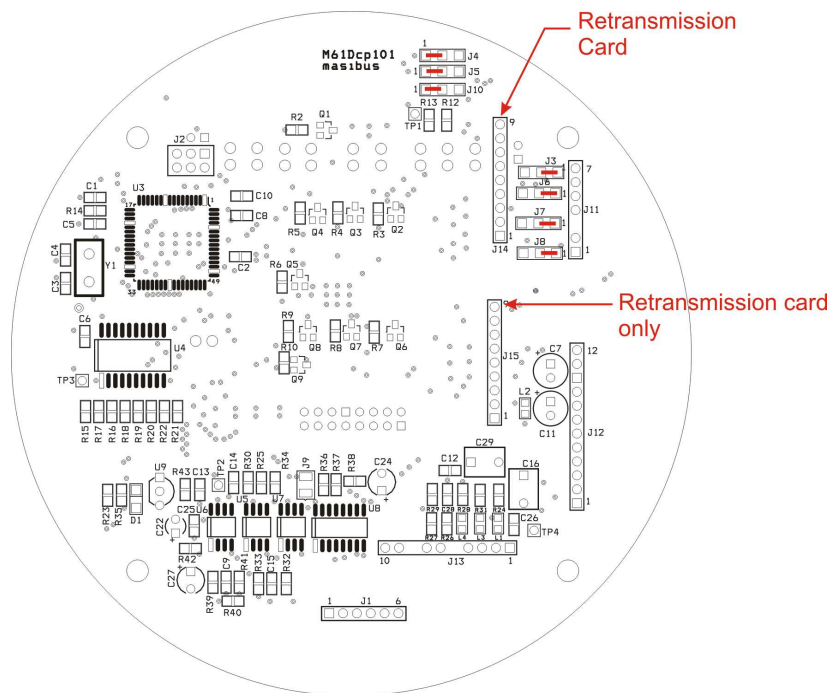

- There are mainly Two types of Retransmission Output is available:
 - Voltage (0-10VDC, 0-5VDC, 1-5VDC)
 - Current (4-20mADC, 0-20mADC)
- This can be Settable by changing the Position of Shorting Link Jumpers on Retransmission Addon Card shown in below figure.

- Jumper Setting for Retransmission card: m61Cao201

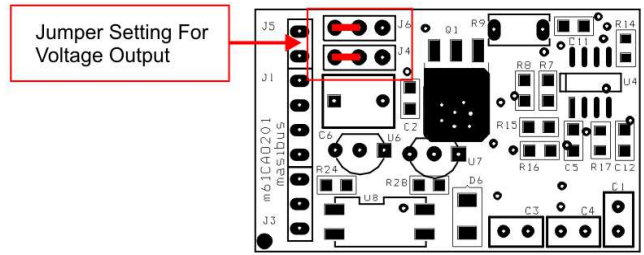
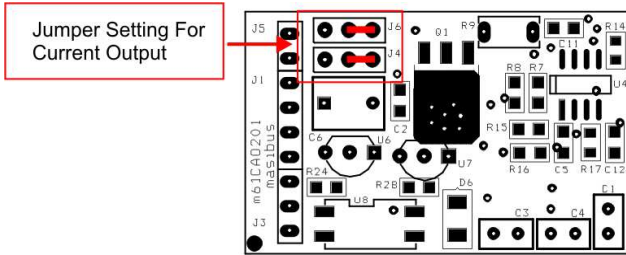

- Jumper Setting for Retransmission card: m61Cao102

