

masibus®

User's Manual

ON-OFF CONTROLLER

LC5296 DC

Dual Channel Temperature Controller



Masibus Automation & Instrumentation Pvt. Ltd.

B/30, GIDC Electronics Estate,
Sector-25, Gandhinagar-382044, Gujarat, India

☎ +91 79 23287275-79 📠 +91 79 23287281-82

Email: support@masibus.com

Web: www.masibus.com

Contents

1. INTRODUCTION..... 4

 Foreword 4

 Notice 4

 Trademarks 4

 Product Ordering Code 4

 List of Accessories 5

 Safety Precautions 5

2. SPECIFICATIONS 6

 2.1 Inputs..... 6

 2.2 Display & Keys 6

 2.3 Output Types..... 6

 2.4 Communication Details..... 7

 2.5 Power Supply 7

 2.6 Environmental Conditions..... 8

 2.7 Special Feature: 8

3. PHYSICAL SPECIFICATIONS & MOUNTING DETAILS..... 9

4. TERMINAL CONNECTIONS 10

 10

 4.2 How to connect wires? 11

5. FRONT PANEL DETAILS 13

 5.1 Front Panel Description 13

6. MENU LAYOUT 15

 6.1 Run Time Indication/Function..... 16

 6.2 Set Point Setting..... 16

 6.3 Configuration Mode 16

 6.4 Map Mode 20

 6.5 Calibration Mode 21

7. CONTROL FUNCTION..... 23

 7.1 ON/OFF Control 23

8. CALIBRATION PROCEDURE..... 24

 8.1 Procedure for CAL-zero and CAL-span..... 24

8.2	Procedure for RET-zero and RET-span	24
9.	COMMUNICATION PROTOCOL–MODBUS RTU.....	25
9.1	Introduction.....	25
9.2	Parameter Address Details.....	25
9.3	Exceptional Response.....	26
10.	APPENDIX.....	27
10.1	Troubleshooting.....	27
10.2	On-Off Logic	27
10.3	Retramission Output Table for Open /Over /Under Condition	28
10.4	Mapping Table for Relay and Retransmission Conditions	28
10.5	Jumper Settings for Add-on Card Selection & Retransmission	29
10.6	Load connection	30

1. INTRODUCTION

Foreword

Thank you for purchasing Dual Channel ON-OFF Temperature Controller-LC5296-DC.

This manual describes the basic functions and operation methods. Please read through this user's manual carefully before using the product.

Notice

The contents of this manual are subject to change without notice as a result of continuous improvements to the instrument's performance and functions.

Every effort has been made to ensure accuracy in the preparation of this manual. Should any errors or omissions come to your attention, however, please inform MASIBUS Sales office or sales representative. Under no circumstances may the contents of this manual, in part or in whole, be transcribed or copied without our permission.

Trademarks

Our product names or brand names mentioned in this manual are the trademarks or registered trademarks of Masibus Automation and Instrumentation (P) Ltd. (herein after referred to as MASIBUS).

Adobe, Acrobat, and Postscript are either registered trademarks or trademarks of Adobe Systems Incorporated. All other product names mentioned in this user's manual are trademarks or registered trademarks of their respective companies.

Checking the Contents of the Package

Unpack the box and check the contents before using the product. If the product is different from which you have ordered, if any parts or accessories are missing, or if the product appears to be damaged, contact your sales representative.

Product Ordering Code

The Single Loop Controller unit has a nameplate affixed to the one side of the enclosure. Check the model and suffix codes inscribed on the nameplate to confirm that the product received is that which was ordered

Ordering Code												
Model	Input-1*		Input-2		Power Supply		Options				Relay o/p	
							Output-1		Output-2			
LC5296-DC	9	Pt-100	9	Pt-100	U1	85-265VAC / 100-300VDC	N	None	N	None	N	None
	C	4-20mA	C	4-20mA	U2	18-36 VDC	1	4-20 mA	1	4-20 mA	Y	Yes
	D	0-20mA	D	0-20mA			2	0-20 mA	2	0-20 mA		
	E	1-5V	E	1-5V			3	1-5V	3	1-5V		
	F	0-5V	F	0-5V			4	0-5V	4	0-5V		
	G	0-10V#					5	0-10V	5	0-10V		
									6	RS485		

*Transmitter Power Supply not possible for RTD input type
 # Possible for Channel-1 only.

List of Accessories

The product is provided with the following accessories according to the model and suffix codes (see the table below). Check that none of them are missing or damaged.

No	Item name	Part number	Qty	Remarks
1	Mounting Clamps	-	2	

Safety Precautions

The product and the instruction manual describe important information to prevent possible harm to users and damage to the property and to use the product safely.

Understand the following description (signs and symbols), read the text and Observe Descriptions.

DESCRIPTION OF SIGNS

	WARNING	<i>This indicates a danger that may result in death or serious injury if not avoided.</i>
--	----------------	---

	CAUTION	<i>This indicates a danger that may result in minor or moderate injury or only a physical damage if not avoided.</i>
--	----------------	--

2. SPECIFICATIONS

2.1 Inputs

Analog Input	
Input-1 Type	RTD (Pt100), Current, Voltage
Input-2 Type	RTD (Pt100), Current, Voltage
Display Range	Refer Table-2.1
Accuracy ⁺	+ (0.25% of Full Span + 1 degree) RTD input. + (0.1% of Full Span + 1 count) for Linear input.
ADC Resolution	16 bits
Display Resolution	0.1°C / 1 Count
Sampling Rate	4 Samples/Sec
Sensor open Detection	All inputs except 0-5V
Sensor Burnout current	0.25uA
RTD excitation current	0.166mA (Approx)
Allowable wiring resistance for RTD	Maximum 15 ohms/wire (Conductor resistance between three wires should be equal)
NMRR	> 40 dB
CMRR	> 120 dB
Temp-co	< 150ppm/°C
Input Impedance	> 1MΩ (Voltage Input) 250Ω (Current Input)
Max Voltage	20VDC

⁺ Channel to Channel interference: 0.1% of Full Span

Input-1 type	Input-2 type	Range
PT100 (0.1°C)	PT100 (0.1°C)	-199.9 to 850.0 °C
PT100 (1°C)	PT100 (1°C)	-200 to 850°C
*4-20mA /1-5VDC, *0-20mA /0-5VDC, 0-10VDC	*4-20mA /1-5VDC, *0-20mA /0-5VDC,	-1999 to 9999 (Field Scalable)

Table-2.1 *Use external 250ohms, 0.1% for current Input

2.2 Display & Keys

Display	Specification
PV 1 Display	4-Digit, 7-Segment, Red, Character height of 0.56"
PV 2 / Process Parameter	4-Digit, 7-Segment, Red, Character height of 0.56"
Status Indication	Individual RED Led for Relay & Communication Status

2.3 Output Types

Relay Output	
Relays	2
Type	Single Change over Three Terminals (C, NO, NC)
Rating	2A @ 230VAC / 30VDC

Retransmission Output	
Number of output	1 / 2
Retransmission mapping	With respect to Input no.
Output Signal	4-20mA / 0-20mA /1-5VDC / 0-10V DC
Load resistance	<ul style="list-style-type: none"> • For Current o/p < 500Ω. • For Voltage o/p > 3KΩ.
Output accuracy	±0.25% of span

Loop Power Supply	
Supply Voltage	24VDC (±1V) @60mA with Inbuilt Short Circuit Protection

2.4 Communication Details

Communication	
Interface	RS485 (2 Wire)
Protocol	Modbus-RTU
Baud rate	9600, 19200, 38400 bps

2.5 Power Supply

Standard	85-265VAC/ 100-300VDC
Optional	18-36VDC
Power consumption	<10VA
Data backup	Non-volatile memory (can be written up to 100000 times)

Isolation (Withstanding voltage)

- Between primary terminals* and secondary terminals**:
At least 1500 V AC for 1 minute
- Between primary terminals* and grounding terminal:
At least 1500 V AC for 1 minute
- Between grounding terminal and secondary terminals**:
At least 1500 V AC for 1 minute
- Between secondary terminals**:
At least 500 V AC for 1 minute

* Primary terminals indicate power terminals and relay output terminals.

** Secondary terminals indicate analog I/O signal and Communication O/P.

Insulation resistance: 20MΩ or more at 500 V DC between power terminals and grounding terminal.

2.6 Environmental Conditions

TEMPCO	For Input-1 to PV1 Display < 100ppm. For Input-2 to PV2 Display < 100ppm.
Humidity	30% to 95% RH (Non-Condensing)
Instrument Warm-up Time	Approx. 15 minutes
Ambient temperature	0 to 55°C
Storage Temperature	0 to 80°C

2.7 Special Feature:

- 1 Relay mapping with respect to input no.
- 2 Retransmission output mapping with respect to input no.

3. PHYSICAL SPECIFICATIONS & MOUNTING DETAILS

Front Bezel	96 x 96 mm
Panel Cutout	92mm(+0.8) x 92mm(+0.8)
Depth Behind The Panel	65 mm with Terminal
Weight	300g Approx.
Enclosure Material	ABS
Enclosure Protection	IP20
Terminal Cable Size	2.5 mm ²

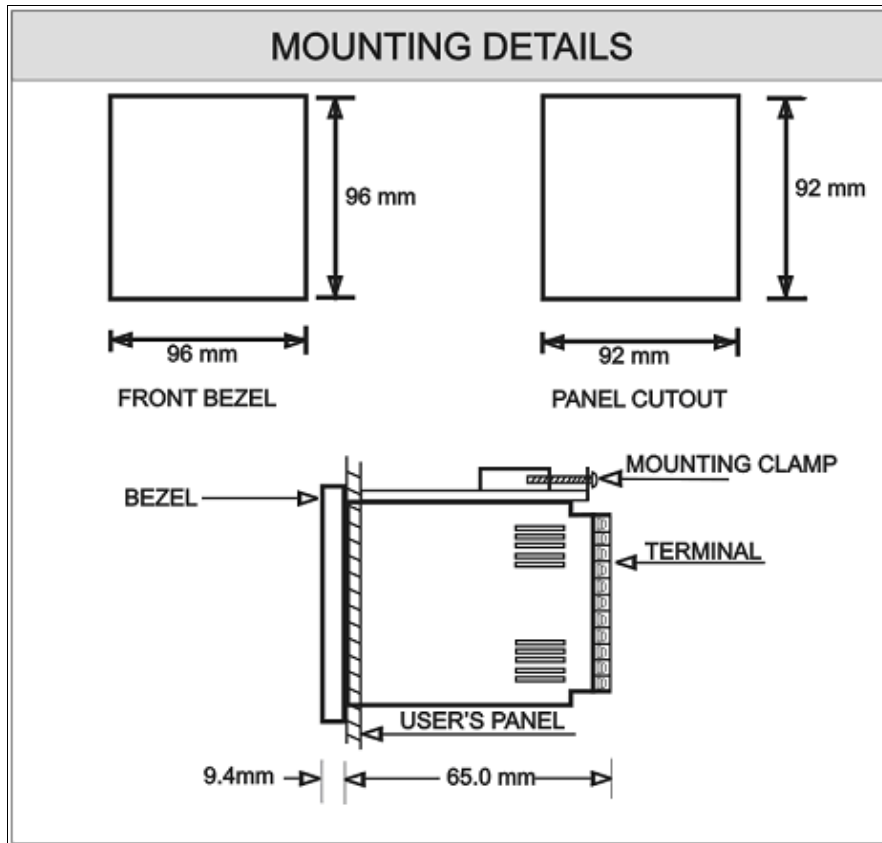

Fig 3.1: Mounting Details for LC5296 -DC

4. TERMINAL CONNECTIONS

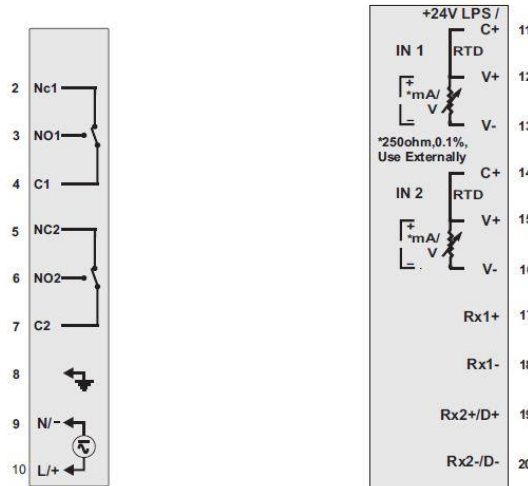

Fig 4.1: Terminal Connection Detail of LC5296-DC

Terminal No.	Description
2 (NC1) 3 (NO1) 4 (C1)	<ul style="list-style-type: none"> For Relay-1 potential free Contacts (Use 230V -2A load) On-Off Control o/p.
5 (NC2) 6 (NO2) 7 (C2)	<ul style="list-style-type: none"> For Relay-2 potential free Contacts (Use 230V -2A load) On-Off Control o/p.
8 (Earth)	Earth Connection
9 (N/-) 10 (L/+)	Power Supply Input
11 (24+ LPS/C+)	24VDC Loop power supply Terminal 13 is ground Reference or for RTD input-1 (Three wire Compensation).
12 (V+)	For RTD Input-1 or Linear Input -1.
13 (V-)	For RTD Input-1 or Linear Input -1.
14 (C+)	For RTD input -2 only (Three wire Compensation).
15 (V+)	For RTD Input-2 or Linear Input -2.
16(V-)	For RTD Input-2 or Linear Input -2.
17 (Rx1+) 18 (Rx1-)	<ul style="list-style-type: none"> For Retransmission-1 output
19 (Rx2+ / D+) 20 (Rx2- / D-)	<ul style="list-style-type: none"> For Retransmission-2 output Modbus-RTU Communication Output

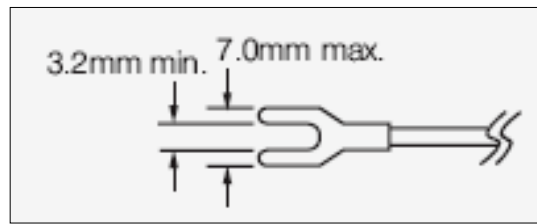

Fig 4.5: Lead Termination Detail

4.2 How to connect wires?

Before carrying out wiring, turn off the power to the controller and check that the cables to be connected are not alive because there is a possibility of electric shock.

NOTE:

- ✓ All wiring must confirm to appropriate standards of good practice and local codes and regulations. Wiring must be suitable for Voltage, Current and temperature rating of the system.
- ✓ Provide power from a single-phase instrument power supply. If there is a lot of noise in the power line, insert an insulating transformer into the primary side of the line and use a line filter on the secondary side. Do not place the primary and secondary power cables close to each other.
- ✓ For RTD input, use shielded wires that have low conductor resistance and cause no significant differences in resistance between the three wires.
- ✓ Use repeater after each set of 32 instruments connected in RS-485 Communication.
- ✓ Unused terminals should not be used as jumper points as they may be internally connected, which may cause damage to the unit.
- ✓ Unused control terminals should not be used as jumper points as they may be internally connected, which may cause damage to the unit.
- ✓ Use >250V-1Amp Cable for Power Supply.
- ✓ Supply voltage must be below maximum voltage rating specified on the label
- ✓ If cable has two parallel wires inside then isolation between them must be 2.5 KV.



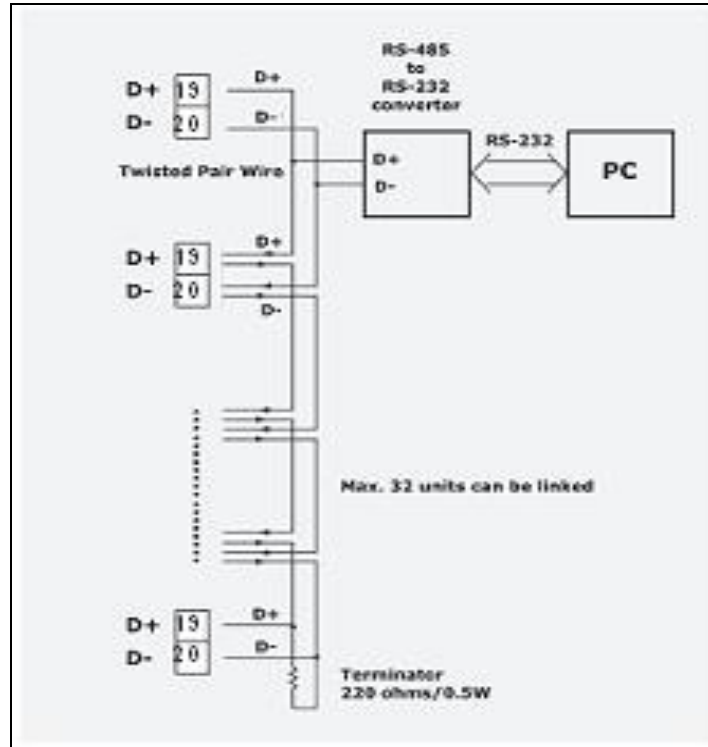
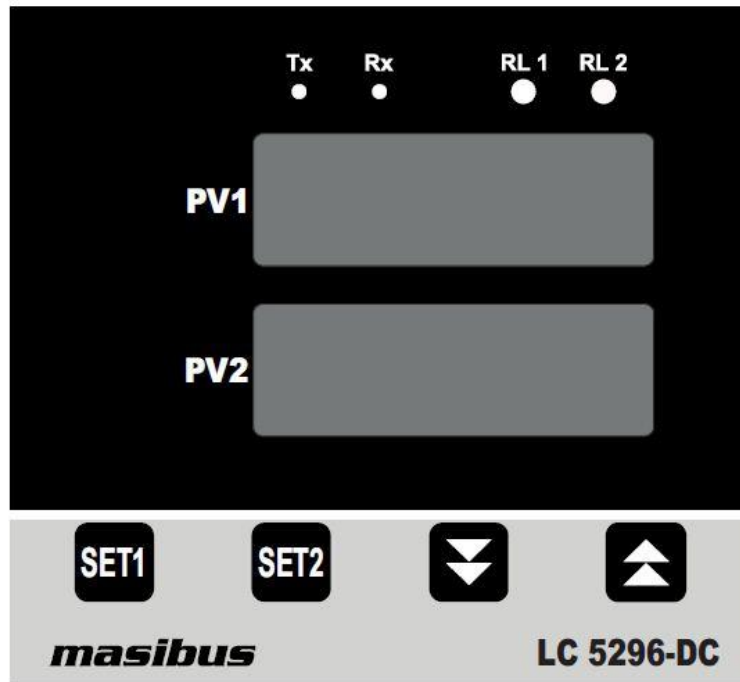





Fig 4.4: RS485 Connection Details

5. FRONT PANEL DETAILS



5.1 Front Panel Description

Name of Part	Symbol	Function	LC5296-DC
Increment Key		<ul style="list-style-type: none"> Increment the Value of any Parameter. 	✓
Decrement Key		<ul style="list-style-type: none"> Decrement the Value of any Parameter. Shows ambient value for T/C Input in RUN mode. 	✓
SET-1 Key (Menu / Enter Key)		<ul style="list-style-type: none"> Shows Set Point-1(ST-1), if pressed in RUN mode. In Sub Menu it can be used to get to the next Parameter. It is also used to save the parameters to nonvolatile memory, when user setting a proper data by Increment and decrement key for parameter configuration. 	✓
SET-2 Key		<ul style="list-style-type: none"> Shows Set Point-1(ST-2), if pressed in RUN mode. Also used to store modified SetPoint-2 Value. 	✓

PV (Present Value) Display	PV1	<ul style="list-style-type: none"> • 4 digital 0.56 inch RED Display • Display parameter name when user set parameter. • Display Parameter Value when in Edit mode. (For Single Display Model Only) • Display error message when an error occurs. 	✓
PV 2 (Process Value) Display	PV2	<ul style="list-style-type: none"> • 4 digital 0.56 inch RED • Display process value for Input 2 • Display parameter value of parameter in process value field when user set parameter. 	✓
Relay-1 Indication	RL1	<ul style="list-style-type: none"> • ON when Relay-1 is energized & OFF otherwise. 	✓
Relay-2 Indication	RL2	<ul style="list-style-type: none"> • ON when Relay-2 is energized & OFF otherwise. 	✓
TX Indication	Tx	<ul style="list-style-type: none"> • ON when device is transmitting some Data (RS-485). 	✓
RX Indication	Rx	<ul style="list-style-type: none"> • ON when device is receiving some Data (RS-485). 	✓

6. MENU LAYOUT

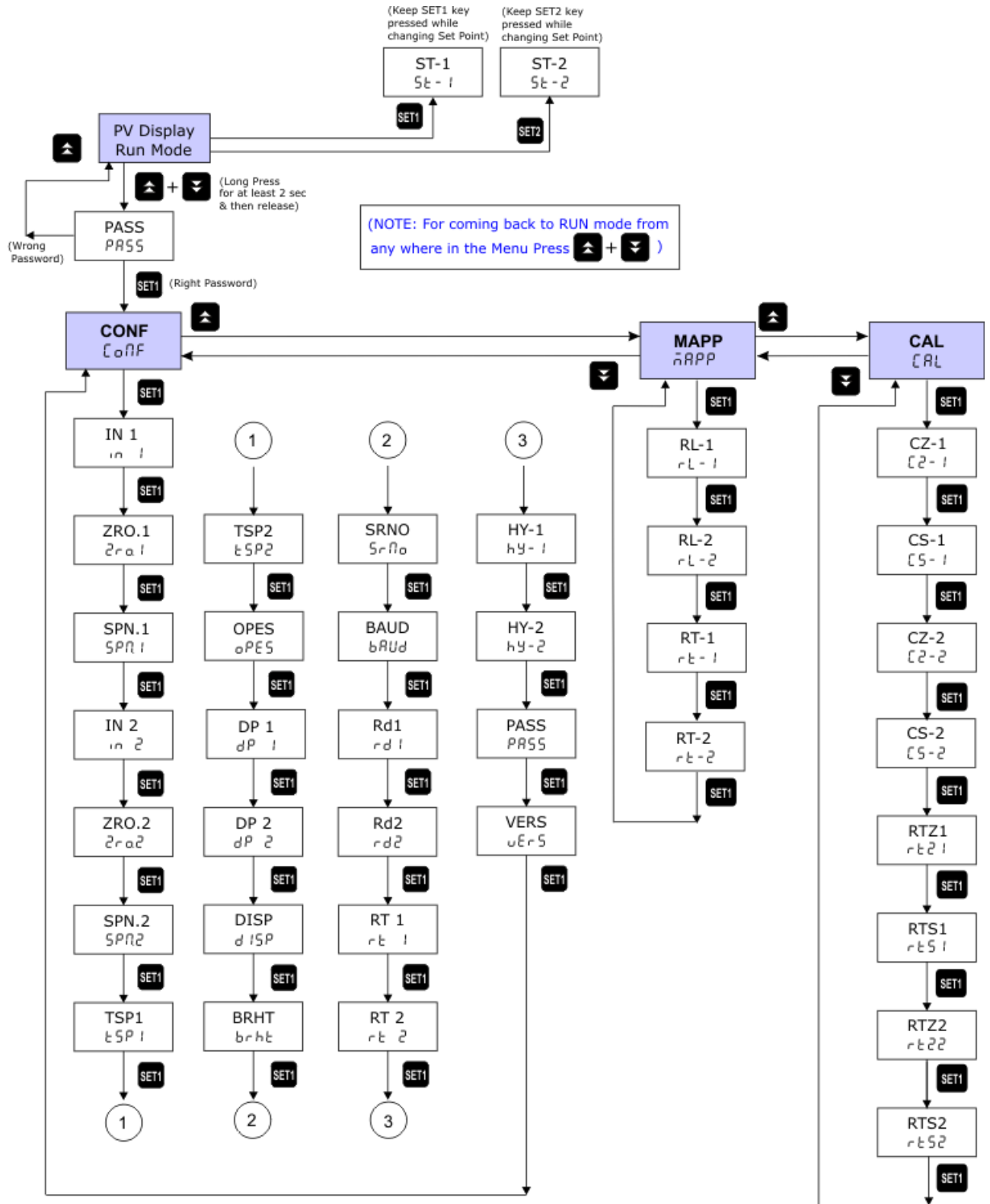

6.1 Run Time Indication/Function

Following parameters can view or change during run time.

- In upper display, it shows Process value for input-1.
- In lower display, it shows Process value for input-2.

6.2 Set Point Setting

Parameter (PV display)		Setting name and description	Default value	Shows only if
Symbol	Name			
ST-1 (5t-1)	Set Point 1	Range Depending on PV sensor type selected	100	-
ST-2 (5t-2)	Set Point 2	Range Depending on PV sensor type selected	200	-

6.3 Configuration Mode

Parameter (PV display)		Setting Name & Description	Default Value	Show if Only														
Symbol	Name																	
INPT (in 1)	INPUT Type	Set PV Input -1 Type <i>rtd .1 / rtd / 0-5u / 1-5u</i> <table border="1" style="margin-top: 10px;"> <thead> <tr> <th>Value</th> <th>Input Type</th> <th>Range</th> </tr> </thead> <tbody> <tr> <td>7</td> <td>RTD.1</td> <td>-199.9 to 850.0 °C</td> </tr> <tr> <td>8</td> <td>RTD</td> <td>-200 to 850 °C</td> </tr> <tr> <td>9</td> <td>0-5 V / 0-20 mA*</td> <td rowspan="2">-1999 to 1999</td> </tr> <tr> <td>10</td> <td>1-5 V / 4- 20 mA*</td> </tr> </tbody> </table> <p>*Use external 250ohms,0.1% for current input</p>	Value	Input Type	Range	7	RTD.1	-199.9 to 850.0 °C	8	RTD	-200 to 850 °C	9	0-5 V / 0-20 mA*	-1999 to 1999	10	1-5 V / 4- 20 mA*	0-5V	
Value	Input Type	Range																
7	RTD.1	-199.9 to 850.0 °C																
8	RTD	-200 to 850 °C																
9	0-5 V / 0-20 mA*	-1999 to 1999																
10	1-5 V / 4- 20 mA*																	
ZERO (zro .1)	Zero-1	Automatically change to the Input Lower Range with changing of Input Type (Refer Above Table) Can be set to any value within the Input Range & less the SPAN Value.	-1999 (If 0-5V)															
SPN.2 (SPn .2)	Span-1	Automatically change to the Input Higher Range with changing of Input Type (Refer Above Table) Can be set to any value within the Input Range & greater the ZERO Value.	9999 (If 0-5V)															

IN 2 (In 2)	Input-2 Type	Set PV Input -2 Type rtd .1 / rtd/ 0-5v / 1-5v	0-5 V											
		<table border="1"> <thead> <tr> <th>Value</th> <th>Input Type</th> <th>Range</th> </tr> </thead> <tbody> <tr> <td>7</td> <td>RTD.1</td> <td>-199.9 to 850.0 °C</td> </tr> <tr> <td>8</td> <td>RTD</td> <td>-200 to 850 °C</td> </tr> <tr> <td>9</td> <td>0-5 V / 0-20 mA*</td> <td rowspan="2">-1999 to 1999</td> </tr> <tr> <td>10</td> <td>1-5 V / 4- 20 mA*</td> </tr> </tbody> </table> <p>*Use external 250ohms,0.1% for current input</p>			Value	Input Type	Range	7	RTD.1	-199.9 to 850.0 °C	8	RTD	-200 to 850 °C	9
Value	Input Type	Range												
7	RTD.1	-199.9 to 850.0 °C												
8	RTD	-200 to 850 °C												
9	0-5 V / 0-20 mA*	-1999 to 1999												
10	1-5 V / 4- 20 mA*													
Zro.2 (Zro .2)	Zero-2	Automatically change to the Input Lower Range with changing of Input Type (Refer Above Table) Can be set to any value within the Input Range & less the SPAN Value.	-1999 (If 0-5 V)											
SPN.2 (SPn .2)	Span-2	Automatically change to the Input Higher Range with changing of Input Type (Refer Above Table) Can be set to any value within the Input Range & greater the ZERO Value.	9999 (If 0-5 V)											
TSP1 (tSP 1)	Type of Set Point-1	Set Type of Set Point L-on / H-on 0 : L-ON (Lower ON) 1 : H-ON (Higher ON) Refer ON-OFF Control on Page:30	0 (L-ON)											
TSP2 (tSP2)	Type of Set Point-2	Set Type of Set Point L-on H-on 0 : L-ON (Lower ON) 1 : H-ON (Higher ON) Refer ON-OFF Control on Page:30	0 (L-ON)											
OPES (oPE5)	OPEN Sensor Status	Set Control O/P & Retransmission state when Input OPEN condition. doūn / UP 0 : DOWN 1 : UP Refer Page:35	0 (DOWN)											
DP 1 (dP 1)	Decimal Point	Set position of Decimal Point on Display. 0 / 0 .0 / 0 .00 / 0 .000	0											

		0 : 0 0.0 : 1 0.00 : 2 0.000 : 3		
DP 2 (dP 2)	Decimal Point- Input- 2	Set position of Decimal Point on Display for PV2. 0 / 0 .0 / 0 .00 / 0 .000 0 : 0 1 : 0.0 2 : 0.00 3 : 0.000	0	Input Type is Linear
BRHT (brHt)	Brightness	Adjust Brightness of the 7-segment Display. 10 to 100	50	
SRNO (Srno)	Serial No.	Unit ID for Modbus-RS485 Communication 1 to 247	1	If Device Supports RS- 485 Communicatio n
BAUD (bAud)	Baud Rate	Set Modbus RS485 Communication Baud Rate 9600 / 19 .2K / 38 .4K 0 : 9600 (9600 bps) 1 : 19.2K (19200 bps) 2 : 38.4K (38400 bps)	0 (9600)	If Device Supports RS- 485 Communicatio n
RD 1 (rd 1)	Relay Delay (For Relay-1)	Relay Delay is amount of time (in sec), that Relay 1 will wait before getting ON after the ON condition occurs. 0 to 99 sec	1 sec	
RD 2 (rd 2)	Relay Delay (For Relay-2)	Relay Delay is amount of time (in sec), that Relay 2 will wait before getting ON after the ON condition occurs. 0 to 99 sec	1 sec	

<p>RT-1 (rt-1)</p>	<p>Retransmission 1 Type</p>	<p>Retransmission-1 Output Type This output is according to PV input. Zero & Span acts as Min & Max value of retransmission o/p scale respectively.</p> <p><i>0-5v / 1-5v / 0-10 / 4-20 / 0-20</i></p> <p>0 : 0-5V 1 : 1-5V 2 : 0-10V 3 : 4-20mA 4 : 0-20mA</p> <p>Voltage or Current is Jumper Selectable from the Hardware.</p>	<p>0 (0-5V)</p>													
<p>RT-2 (rt-2)</p>	<p>Retransmission 2 Type</p>	<p>Retransmission-2 Output Type This output is according to PV input. Zero & Span acts as Min & Max value of retransmission o/p scale respectively.</p> <p><i>0-5v / 1-5v / 0-10 / 4-20 / 0-20</i></p> <p>0 : 0-5V 1 : 1-5V 2 : 0-10V 3 : 4-20mA 4 : 0-20mA</p> <p>Voltage or Current is Jumper Selectable from the Hardware.</p>	<p>0 (0-5V)</p>	<p>if Device supports Dual Retransmission Output</p>												
<p>HY-1 (HY-1)</p>	<p>Hysteresis – 1 (For Relay-1)</p>	<p>Hysteresis Value (in °C) for Relay-1 during ON-OFF type Control.</p> <table border="1" data-bbox="525 1440 1070 1704"> <tr> <td>1 to 100</td> <td>RTD Input</td> </tr> <tr> <td>0.1 to 10.0</td> <td>RTD.1 Input</td> </tr> <tr> <td>1 to 100</td> <td>Linear Input with DP=0</td> </tr> <tr> <td>0.1 to 10.0</td> <td>Linear Input with DP=1</td> </tr> <tr> <td>0.01 to 1.00</td> <td>Linear Input with DP=2</td> </tr> <tr> <td>0.001 to 0.100</td> <td>Linear Input with DP=3</td> </tr> </table>	1 to 100	RTD Input	0.1 to 10.0	RTD.1 Input	1 to 100	Linear Input with DP=0	0.1 to 10.0	Linear Input with DP=1	0.01 to 1.00	Linear Input with DP=2	0.001 to 0.100	Linear Input with DP=3	<p>5</p>	
1 to 100	RTD Input															
0.1 to 10.0	RTD.1 Input															
1 to 100	Linear Input with DP=0															
0.1 to 10.0	Linear Input with DP=1															
0.01 to 1.00	Linear Input with DP=2															
0.001 to 0.100	Linear Input with DP=3															

HY-2 (HY-2)	Hysteresis – 2 (For Relay-2)	Hysteresis Value (in °C) for Relay-2 during ON-OFF type Control.		5	
		1 to 100	RTD Input		
		0.1 to 10.0	RTD.1 Input		
		1 to 100	Linear Input with DP=0		
		0.1 to 10.0	Linear Input with DP=1		
		0.01 to 1.00	Linear Input with DP=2		
0.001 to 0.100	Linear Input with DP=3				
PASS (PASS)	Password	Set Device Password 0 to 99		1	
VERS (VER5)	Version	Shows the Version of the Current Firmware		-	

6.4 Map Mode

MAP PARAMETERS				
Parameter (PV display)		Setting Name & Description	Default Value	Show if Only
Symbol	Name			
RL-1 (rL-1)	Map Relay-1	For mapping relay-1	IN 1	
RL-2 (rL-2)	Map Relay-2	For mapping relay-2	IN 1	
RT-1 (rT-1)	Map retransmission-1	For mapping retransmission-1	IN 1	Device Supports Retransmission Output.
RT-2 (rT-2)	Map retransmission-2	For mapping retransmission-2	IN 1	Device Supports Dual Retransmission Output.

NOTE:-

➤ Please refer Table no.10.4 mapping options for Relay and Retransmission.

6.5 Calibration Mode

CALIBRATION PARAMETERS				
Parameter (PV display)		Setting Name & Description	Default Value	Show if Only
Symbol	Name			
CZ-1 ([2-1])	Calibration Zero-1	Calibration Zero for PV Input-1 (PV Display : Current PV)	-	
CS-1 ([5-1])	Calibration Span-1	Calibration Span for PV Input-1 (PV Display : Current PV)	-	
CZ-2 ([2-1])	Calibration Zero-2	Calibration Zero for PV Input-2 (PV Display : Current PV)	-	
CS-2 ([5-2])	Calibration Span-2	Calibration Span for PV Input-2 (PV Display : Current PV)	-	
RTZ1 (r[21])	Retransmission Zero-1	Calibration Zero for Retransmission Output-1 (SV Display : If voltage: 0.000 If Current: 4.000)	-	Device Supports Retransmission Output
RTS1 (r[51])	Retransmission Span-1	Calibration Span for Retransmission Output-1 (SV Display : If voltage: 8.000 If Current: 20.00)	-	Device Supports Retransmission Output
RTZ2 (r[22])	Retransmission Zero-2	Calibration Zero for Retransmission Output 2 (SV Display : If voltage: 0.000 If Current: 4.000)	-	Device Supports Dual Retransmission Output
RTS2 (r[52])	Retransmission Span-2	Calibration Span for Retransmission Output-2 (SV Display : If voltage: 8.000 If Current: 20.00)	-	Device supports Dual Retransmission Output

NOTE:-

- The retransmission output type is jumper selectable. Thus if current type or voltage type output, will be decided by the position of the jumper.
- No need to feed input while calibrating Rx. o/p. just make the value in calibration mode equal to the displayed value.

Examples:

How to change Input Type?

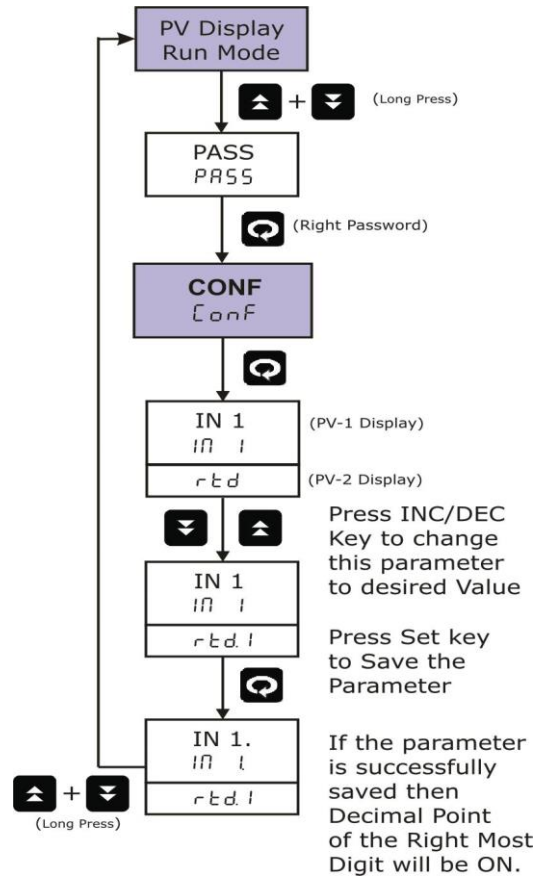

7. CONTROL FUNCTION

7.1 ON/OFF Control

ON/OFF Controller is the simplest form of temperature control device. The output from the device is either on or off, with no middle state. An on-off controller will switch the output only when the temperature crosses the set point. For heating control, the output is on when the temperature is below the set point, and off above set point.

Since the temperature crosses the set point to change the output stage, the process temperature will be cycling continually, going from below set point to above, and back below. In cases where this cycling occurs rapidly, and to prevent contactors and valves from getting damaged, an on-off differential, or “hysteresis,” is added to the controller operations. On-Off hysteresis prevents the output from “chattering” or making fast, continual switches if the cycling above and below the set point occurs very rapidly.

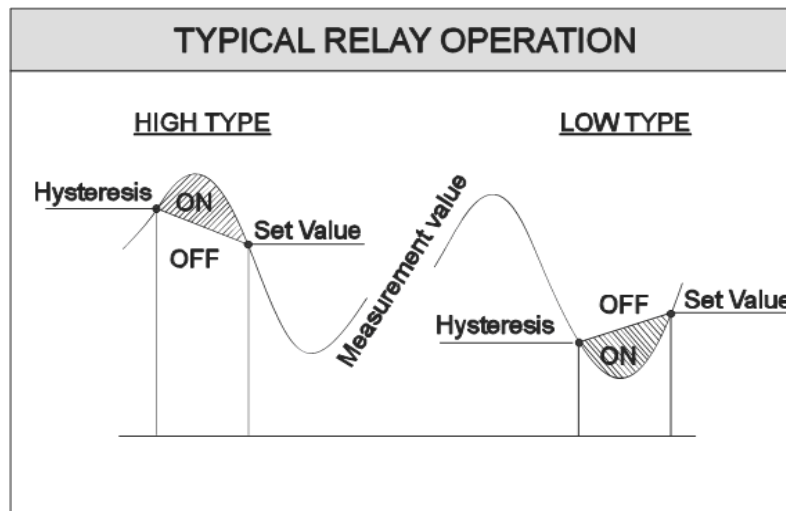

Figure 8.1: Typical Relay operation

High type (H-ON):

For High type of set value, once process value reaches up to set point + Hysteresis value, relay will be ON after few seconds (as per relay delay) and it will be ON until process value goes down to Set point.

Low type (L-ON):

For Low type of set value, once process value reaches down to set point – Hysteresis value relay will be ON after nearly few seconds (as per relay delay) and it will be ON until process value goes up toward Set point.

8. CALIBRATION PROCEDURE

8.1 Procedure for CAL-zero and CAL-span

The instrument is factory calibrated for the specified range, but due to long term drift of components, re-calibration may be necessary in some cases. For calibrating the instrument a reliable source is required. This source should be at least ten times accurate compared to the range of the instrument.

The unit can be calibrated without opening it and without trim pots.

For Entering into the Calibration Mode, Please refer Menu Layout.

After applying appropriate Input from the calibrator source, press 'INCREMENT' OR 'DECREMENT KEY' to bring the actual process value on display.

Example:-

At zero calibration reading expected on the display is 100 and it shows 107, adjust the process value to 100 by using 'DECREMENT KEY'. Now press 'SET' to store the calibration parameter in non-volatile memory. Similarly one can calibrate Ambient, SPAN and retransmission parameters.

8.2 Procedure for RET-zero and RET-span

For calibrating the retransmission output, both retransmission zero and retransmission span has to be calibrated. At a time there can be either one or two retransmission output available. If only one retransmission is used, then calibrate **RTZ1** (retransmission 1 zero) and **RTS1** (retransmission 1 span) and if there are two retransmission outputs available, then calibrate **RTZ2** (retransmission 2 zero) and **RTS2** (retransmission 2 span) for second retransmission. No need to feed input while calibrating retransmission o/p. it is like calibrating using digital trim pot. Only look at the output, display value has no significance with output generated.

Example:-

At retransmission zero calibration, expected output is 4.00mA and it gives 4.153mA. Then adjust the output value to 4.000 by using 'DECREMENT KEY'. Now press 'SET1' to store the calibration parameter in non-volatile memory. Similarly one can calibrate retransmission span.

9. COMMUNICATION PROTOCOL–MODBUS RTU

9.1 Introduction

The unit can be connected in RS-485 communication data link either in multi drop or repeat mode. Each unit must have unique Serial Number. Entire range of addresses (1 to 247) may be used. Before starting any communication, choose a baud rate compatible to the host computer. The serial protocol used is MODBUS RTU.

Function Code for Modbus

CODE	NAME	Function
01	Read coil status	Use to read Relay and Digital output status
03	Read Holding registers	Use to read PV, Control, RSP output etc
04	Read input registers	Use to read programmable registers
06	Preset Single register	Use to write programmable register

The error checking field contains a 16-bit value implemented as two eight-bit bytes. The error check value is the result of a Cyclical Redundancy Check (CRC) calculation performed on the message contents.

9.2 Parameter Address Details

Sr. No.	Parameters	Absolute Address	Type	Access Type
1	PROCESS VALUE-1	30001	Int	Read Only
2	PROCESS VALUE-2	30002	Int	Read Only
3	RELAY-1 STATUS	30003	Int	Read Only
4	RELAY-2 STATUS	30004	Int	Read Only

NOTE: Process Value (PV) Error Conditions Value

OPEN	:	32767
UNDER	:	32765
OVER	:	32766

Sr. No.	Parameters	Absolute Address	Type	Access Type
1	Input Type	40001	Int	R + W
2	Zero	40002	Int	R + W
3	Span	40003	Int	R + W
4	SET Type-1	40004	Int	R + W
5	SET Type-2	40005	Int	R + W
6	Open Sensor Status	40006	Int	R + W
7	Decimal Point	40007	Int	R + W
8	Display set point	40008	Int	R + W
9	Brightness	40009	Int	R + W
10	Serial Number	40010	Int	R + W

11	Baud Rate	40011	Int	R + W
12	Relay Delay -1	40012	Int	R + W
13	Relay Delay -2	40013	Int	R + W
14	Retransmission o/p Type -1	40014	Int	R + W
15	Retransmission o/p Type -2	40015	NA	NA
16	Hysteresis 1	40016	Int	R + W
17	Hysteresis 2	40017	Int	R + W
18	Pass word	40018	Int	R + W
19	Set Value 1	40019	Int	R + W
20	Set Value 2	40020	Int	R + W
21	Input Type-2	40021	Int	R + W
22	Zero-2	40022	Int	R + W
23	Span-2	40023	Int	R + W
24	Decimal Point-2	40024	Int	R + W
25	Relay-1 Map	40025	Int	R + W
26	Relay-2 Map	40026	Int	R + W
27	Retransmission-1 Map	40027	Int	R + W

9.3 Exceptional Response

CODE	MEANING
01	Function code Invalid. It must be 01, 05, 03 or 06.The function code received in the query is not allowable action for the slave.
02	Illegal address value. The data address received in the query is not an allowable address for the slave.
03	Illegal data value. A value contained in the query data field is not an allowable value for the slave.
06	When Master device write some parameters to Slave device, If slave device busy then it will send 06 code to indicate slave device is busy.

TABLE – 8

Note: 1. Refer Menu Mode Description Table the value & Range of each Parameter.

EX:

Input-1 Type (Applicable Range : 5 to 9):

Input-1 Type	Value
Rtd	5
Rtd.1	6
0 – 5V	7
1 – 5V	8
0 – 10V	9

Input-2 Type (Applicable Range : 5 to 8):

Input-1 Type	Value
Rtd	5
Rtd.1	6
0 – 5V	7
1 – 5V	8

10. APPENDIX

10.1 Troubleshooting

If the operating display does not appear after turning on the controller's power, follow the measures in the procedure below.

If a problem appears complicated, contact our sales representative.

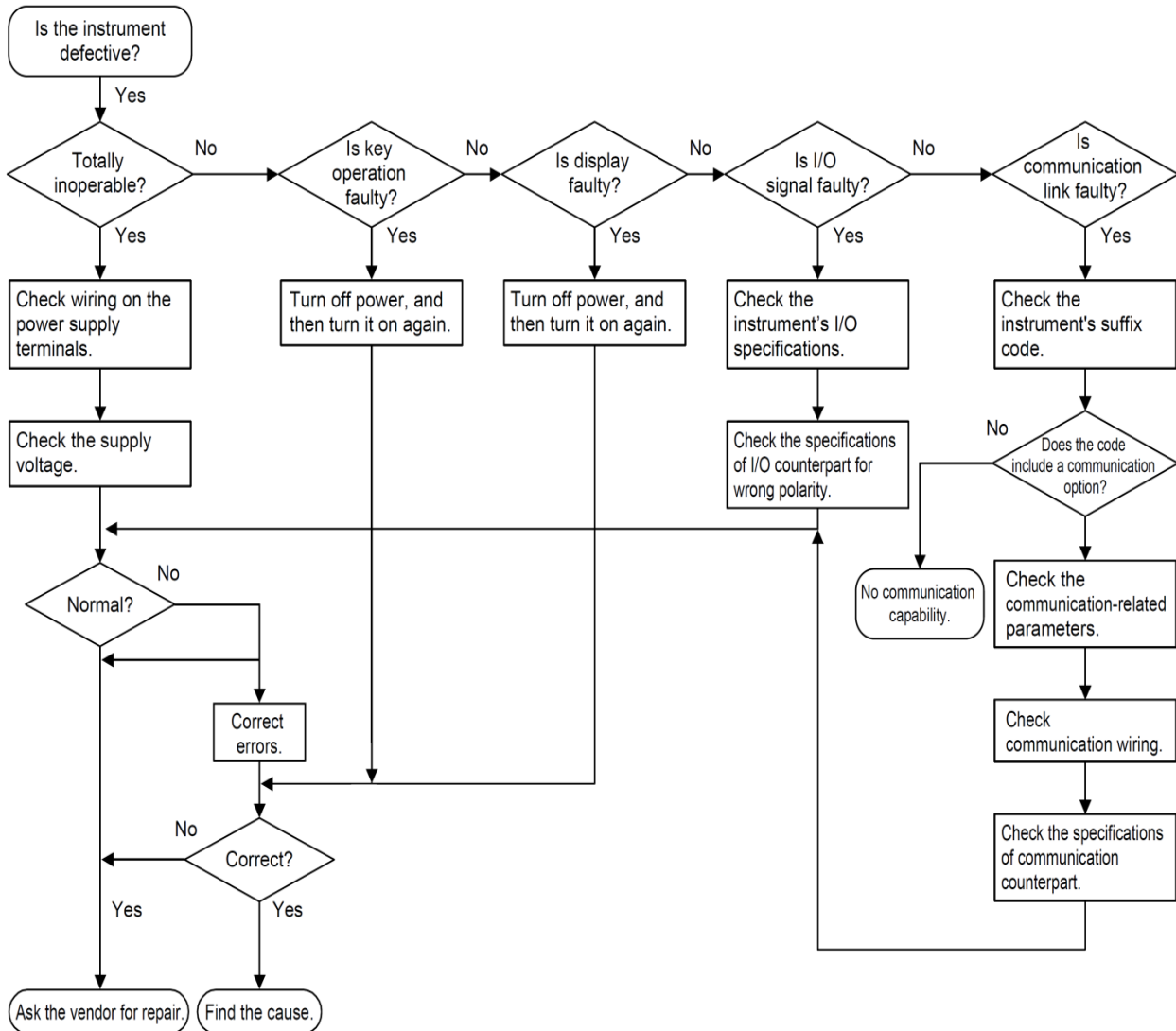

IMPORTANT



Take note of the parameter settings when asking the vendor for repair.

10.2 On-Off Logic

Relay type	PV	Relay	LED
Hi-On	PV > SP	On	On
	PV < SP	Off	Off
Open sensor	Up scale	On	On
	Down scale	Off	Off
Low-On	PV > SP	Off	Off
	PV < SP	On	On
Open sensor	Up scale	Off	Off
	Down scale	On	On

10.3 Retransmission Output Table for Open /Over /Under Condition

RETRASMISSION	VARIABLE	SCALE	ACTION	OPEN	OVER	UNDER
4-20mA	PV	UP	DIR	20.8	20.8	3.2
		DOWN	REV	20.8	3.2	20.8
	PV	UP	REV	3.2	3.2	20.8
		DOWN	DIR	3.2	20.8	3.2
1-5V	PV	UP	DIR	5.2V	5.2V	0.8V
		DOWN	REV	5.2V	0.8V	5.2V
	PV	UP	REV	0.8V	0.8V	5.2V
		DOWN	DIR	0.8V	5.2V	0.8V

NOTE: -1. OPEN/UNDER/OVER condition is applicable to all input types except 0-5v / 0-20mA.

10.4 Mapping Table for Relay and Retransmission Conditions

Mapping for	Parameters	Mapping Options	Description
Relay	RL-1	IN 1	Relay - 1 for Process value 1
		IN 2	Relay - 1 for Process value 2
	RL-2	IN 1	Relay - 2 for Process value 1
		IN 2	Relay - 2 for Process value 2
Retransmission	RT-1	IN 1	Retransmission - 1 for Process value 1
		IN 2	Retransmission - 1 for Process value 2
	RT-2	IN 1	Retransmission - 2 for Process value 1
		IN 2	Retransmission - 2 for Process value 2

10.5 Jumper Settings for Add-on Card Selection & Retransmission

Output Type

- These units come with different Variants differing by various Output option available.
- There are Two Addon Card Slots available on PCB of Signal Card. Among them One Slot is fixed for Retransmission (Analog) Output. And the other Slot can be used for either Retransmission or RS-485 Communication Card by appropriate Jumper setting shown in below figure.
- 0E (SMD 0805) Resistor is used for shorting the Jumper.

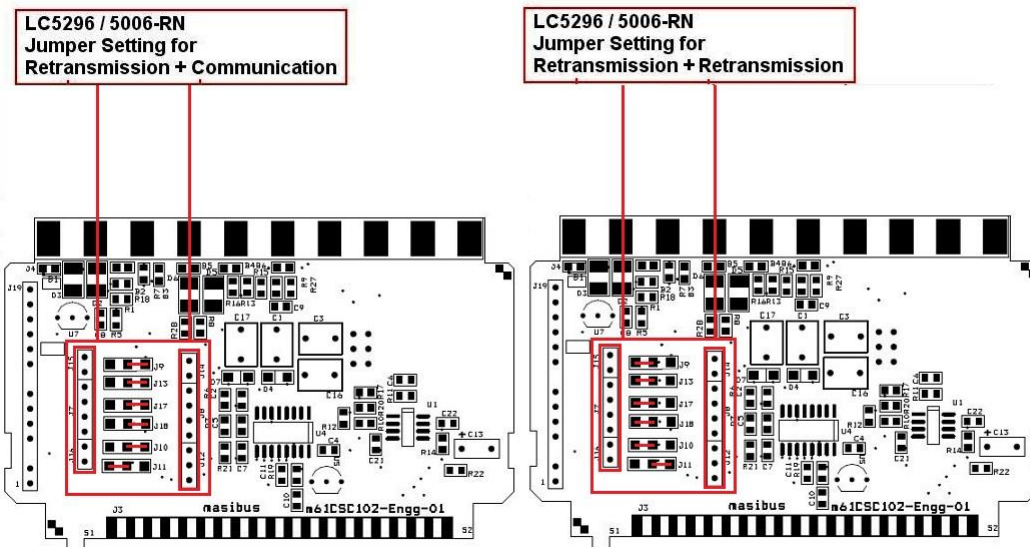

There are mainly Two types of Retransmission Output is available:

- Voltage (0-10VDC, 0-5VDC, 1-5VDC)
- Current (4-20mADC, 0-20mADC)
- This can be Settable by changing the Position of Shorting Link Jumpers on Retransmission Add-on Card shown in below figure.

Jumper Setting for Retransmission card: m61Cao201

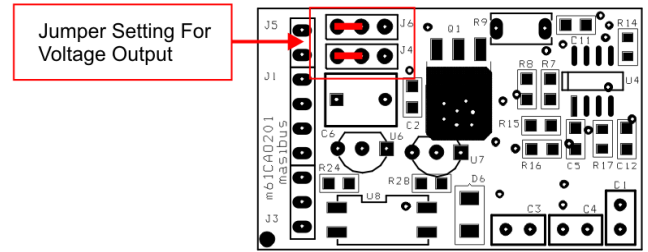
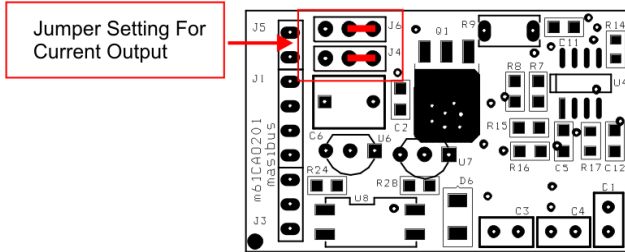

Jumper Setting for Retransmission card: m61Cao102

Jumper Settings for Current Output

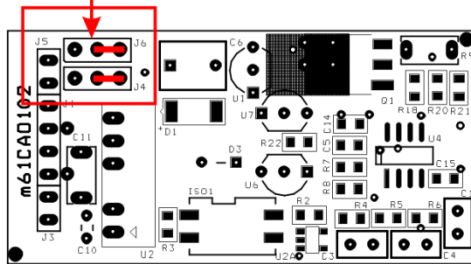

Jumper Settings for Voltage Output

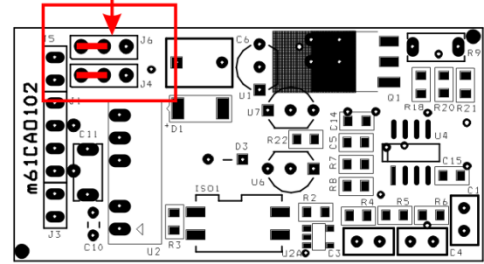

10.6 Load connection

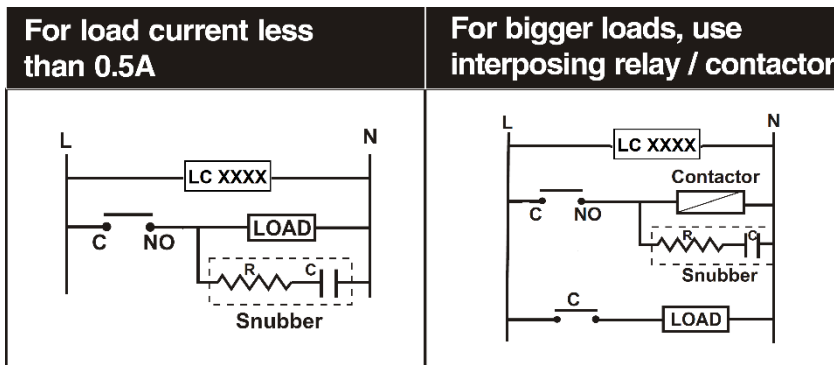

Electrical precautions during use

Electrical noise generated by switching of inductive loads can create momentary disruption, erratic display, latch up, data loss or permanent damage to the instrument. Use of snubber circuits across loads as shown above, is recommended.