

## INDEX

<b>SPECIFICATION</b> .....	<b>1</b>
<b>APPLICATION</b> .....	<b>1</b>
<b>CONNECTION</b> .....	<b>2</b>
<b>SAFETY AND WARNING</b> .....	<b>2</b>
<b>INSTALLATION</b> .....	<b>3</b>
<b>ORDERING CODE</b> .....	<b>3</b>
<b>TROUBLE SHOOTING</b> .....	<b>3</b>

## 8-Channel Analog Linear Module

Masibus Analog Input Field Interface Board has 8 channels that accepts various types of current/voltage signals and converts them to isolated Current / voltage signals. It is compact universal DIN rail mounted with labeled input and output connections. Independent zero & span adjustment for each channel is possible.

### APPLICATION

- Eliminate Ground Loop problems
- Protect Expensive control systems against Field Faults
- Isolate and Translate System Signals
- Eliminate Common Mode Voltages
- Field Interface for PLC/DCS/SCADA systems

### SPECIFICATION

Input	
No. of Channels & Type	8 Channel DC Volt/Current (Factory Set)
Input Range	For Voltage : 1-5VDC,0-5VDC,0-10VDC For Current : 4-20mA,0-20mA
Input Impedance	Current I/P: 100 Ohms / Voltage I/P: >5M
Bad Input Indication	Red LED for over/under range(1-5V/4-20mAonly)
Transmitter Supply	24V ± 10% Current limited@ approximately 25mA
I/P connection	MKDS connector
Output	
Output Type	Voltage/ Current
Output Range	For Voltage : 1-5VDC,0-5VDC,0-10VDC For Current : 4-20mA,0-20mA
Load Impedance	0/1 to 5V@ 1KΩ min, 0 to 10V@ 3KΩ min 0/4mA to 20mA@750Ω max
Response Time	≤3 milli second at full load
Accuracy	0.1% of Span
Drift	0.1% per Year
O/P connection	MKDS connector or 25 Pin D-Type connector
Calibration	Zero & Span Individual per channel by multi-turn trim pots
Power supply	
Power Supply	24VDC ±10%
Power Consumption	< 18VA
Fuse Rating	2Amp (Fast Blown)
LED Indication	Green LED – Healthy Status, Red LED –Fault Status
Isolation	1.5KV AC Input to Power, Channel to Channel , Input to Output and Output to Power
Environmental	
Operating temperature	Operating at 0 to 50°C
Temp. Co-efficient	≤ 100 PPM
Relative humidity	30 to 95% RH non- condense
Environmental Protection	Conformal Coating on PCB
Physical	
Mounting Type	DIN Rail (35 mm width)
Profile Material	PVC
Dimensions	225mm(L) x 90mm(W) x 90mm(D)
Weight	Approx 450 gm
Terminal Detail	
Terminal Block	UL , CSA standard
Terminal Cable Size	Upto 2.5mm <sup>2</sup> conductor

### 8-CHANNEL ANALOG LINEAR MODULE

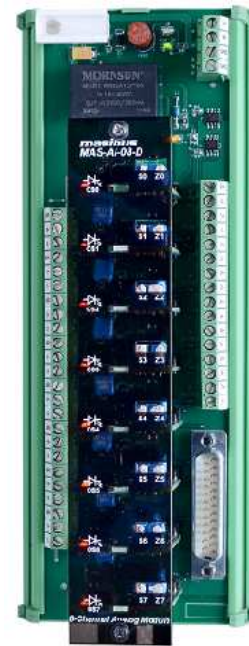

- 8 channel configurations
- Wide range of DC inputs and outputs
- Independent zero & span for each channel
- Easy to calibrate
- Accepts non-std. signal input option
- DIN rail mounted
- Compact Size

### 1. Dimension

225(L) x 90(W) x 90(D)

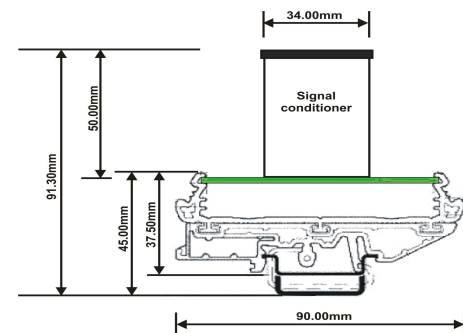

- All Dimension in mm.

## SAFETY AND WARNING

As MAS-AI-08-D with front panel potentiometer calibration, must not be exposed to heavy shocks or vibration which may cause SCM to get out of calibration.

To avoid Electrostatic Discharge (ESD) to the SCM, which may cause permanent damage, always ground yourself by touching some ground equipment.

Before installation or beginning of any troubleshooting procedures the power to all equipment must be switched off and isolated. Units suspected of being faulty must be disconnected and removed first and brought to a properly equipped workshop for testing and repair.

Component replacement and internal adjustments must be made by a company person only. Wiring must be carried out by personnel, who have basic electrical knowledge and practical experience.

All wiring must confirm to appropriate standards of good practice and local codes and regulations. Wiring must be suitable for voltage, current, and temperature rating of the system. Beware not to over-tighten the terminal screws.

## CONNECTION

### Control Elements

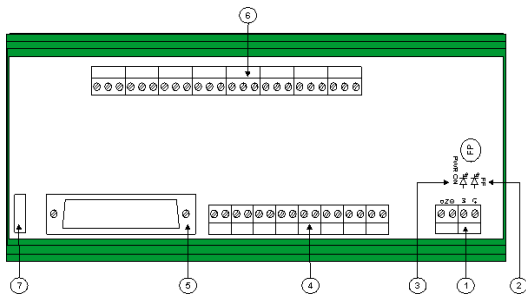

Item nos.	Details
1	Main Power supply with electronic grounding
2	Fuse Fail LED indication
3	Power ON LED indication
4	MKDS Interface connector to DCS
5	25 Pin D Type Male interface connector to DCS
6	Field Input terminals
7	Product serial no.

### Connection details

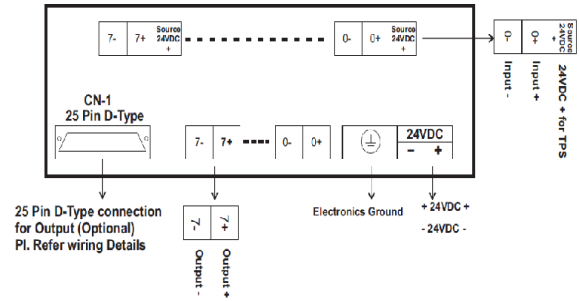

Connect rated power at terminal where 24VDC+ & 24VDC- described in wiring diagram.

Field Input/output Terminals:

Connect input between terminal where Input+ & Input- for particular channel for Input & take output from 25 pin D type PCB mounted male connector or from terminal where Output+ & Output- described in Connection Details.

### Output Connection Details for 25 Pin D type

Pin No.	Description
1	Output0+
2	Output0-
3	Output1+
4	Output1-
5	Output2+
6	Output2-
7	Output3+
8	Output3-
9	Output4+
10	Output4-
11	Output5+
12	Output5-
13	Output6+
14	Output6-
15	Output7+
16	Output7-

### BLOCK DIAGRAM

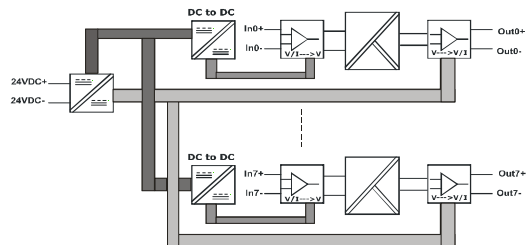

## INSTALLATION

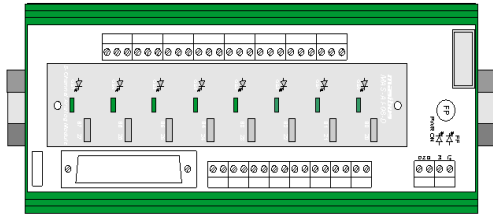

### Mounting:

Place the module with the DIN rail guide way on the **bottom edge** of the DIN rail and then snap it **downwards**.

The housing is mounted on the DIN rail by swiveling it into place.

The Horizontal mounting arrangement Shown here, allows good vertical air circulation. It is also recommended to keep adequate gap between two SCM.

### Removal:

Release the snap-on catch using a screwdriver and then detach the module from the **bottom edge** of the DIN Rail.

First verify that all conventional instrumentation norms have been followed for wiring. Make noise away from the module. Check for ripple on power supplies of Input & Output section.

### ⚠ Output not matching with the expected value

Kindly make sure that the output is really incorrect with respect to input signal, before attempting any re-calibration.

### ⚠ Fluctuation in Reading

The reason can be reverse input connection.

*masibus* Automation & Instrumentation Pvt. Ltd.  
B/30, GIDC Electronics Estate, Sector- 25,  
Gandhinagar-382044, Gujarat, India  
Ph: 91-079-23287275 / 76 / 77 / 78 / 79  
Fax: 91-079-23287281/ 82  
Email: [support@masibus.com](mailto:support@masibus.com)  
Web: [www.masibus.com](http://www.masibus.com)

## ORDERING CODE

ORDERING CODE					
Model	Input Type & Range		Output Type & Range		Output Connection
MAS-AI-08-D	X		X		X
	C	4-20mA	C	4-20mA	0 PCB Terminal Block
	D	0-20mA	D	0-20mA	1 D Type connector
	E	1-5VDC	E	1-5VDC	
	F	0-5VDC	F	0-5VDC	
	G	0-10VDC	G	0-10VDC	
	S	Special	S	Special	
* TPS will be available in case of 4-20mA Input Only					

## TROUBLE SHOOTING

### ⚠ Unit Not Turning ON?

If **RED** LED on the module is ON then problem can be bad connection or due to incorrect rating of power fuse blows. If **GREEN** LED on the module is ON, it indicates the module is in healthy condition.

### ⚠ Unstable/Vague Reading

Check for loose connections.