

User's Manual

SGT-18 Strain Gauge transmitter



Masibus Automation and Instrumentation Pvt. Ltd.

B/30, GIDC Electronics Estate,
Sector-25, Gandhinagar-382044, Gujarat, India
Phone : +91-79-23287275/79.
Fax : +91-79-23287281.
Email: support@masibus.com
Web: www.masibus.com

Contents

1.	Introduction.....	4
1.1	Ordering Code	4
2.	Installation	5
2.1	Environment:.....	5
2.2	Mounting:	5
2.3	Installation Dimensions:	5
2.4	Removal:.....	5
3.	Front Panel.....	6
4.	Dimensions.....	7
5.	Terminal Position Detail:	7
6.	Menu Function List.....	8
7.	Parameter Description.....	9
8.	Menu Guideline	10
8.1	Program Menu	10
8.2	Configuration Menu.....	10
8.3	Calibration Menu.....	11
8.4	Software Version.....	11
9.	Menu Layout.....	12
10.	Modbus Detail:	14
10.1	Configuration parameter Read – write.....	14
10.2	Configuration parameter Read:.....	15
11.	Specifications	17
12.	Relay Logic:.....	19
13.	Appendix:	20
13.1	Internal Jumper Setting For Retransmission Output	20
14.	Troubleshooting:.....	21
15.	Load connection	21

SAFETY PRECAUTIONS

To ensure that the device can be operated safely and all functions can be used, please read these instructions carefully.



Caution: Never carry out work when the Power is turned on, this is dangerous.

Installation and startup must be carried out by qualified personnel only. The relevant country-specific regulations (e.g., VDE, DIN) must also be observed.

Before startup it is particularly important to ensure:

Terminal wiring:

Check that all cables are correctly connected according to the connection diagram

- The mains have been connected correctly and protection is provided against electric shock.
- The device can be switched off outside the power supply according to EN 60950 regulations (e.g., by the line protection on the primary side)
- All supply lines have sufficient fuse protection and are of correct size.
- All output cables are of correct size for the maximum device output current or have separate fuse protection.
- Sufficient convection is ensured.
- After installation the terminal area must be covered to provide sufficient protection against unauthorized access to live parts.

This is ensured by installing the device in the control cabinet or distributor box.

1. Introduction

This is a micro-controller based Strain Gauge Transmitter which is used with strain gauges, load cells and resistance measuring bridges. This instrument provides isolation at 4 levels:

- a) Between input and Power supply
- b) Between output and Power supply.
- c) Between input and output.
- d) Output to Output

1.1 Ordering Code

SGT-18										
Model	Load Excitation Voltage		Auxiliary Power Supply		Retransmission o/p type		Relay o/p		Communication	
SGT-18	X		XX		X		X		X	
	1	5 VDC	U1	85-265 VAC/ 100-300 VDC	1	4-20mA	N	None	N	None
	2	10 VDC	U2	18-36 VDC	2	0-20mA	Y	Yes	Y	RS485
	3	12 VDC			3	1-5VDC				
	4	15 VDC			4	0-5VDC				
	S	Special			5	0-10VDC				

2. Installation

2.1 Environment:



**Caution: Do not install the unit where it is subjected to continuous vibration.
Do not subject the unit to physical impact.**

2.2 Mounting:

The unit can be snapped onto all DIN rails according to EN 60715. The device must be mounted horizontally (input terminal blocks facing downwards)

2.3 Installation Dimensions:



To ensure sufficient convection, a minimum spacing of 3 cm is required.

- 1) Place the module with the DIN rail guide way on the bottom edge of the DIN rail and then snap it downwards.
- 2) The housing is mounted on the DIN rail by swiveling it into place.
- 3) As air vents are provided on the top and bottom part of the unit, the (horizontal) mounting arrangement allows good vertical air circulation.



Vertical mounting arrangement of multiple units must be avoided.

2.4 Removal:

Release the snap-on catch using a screwdriver and then detach the module from the bottom edge of the DIN Rail.

3. Front Panel

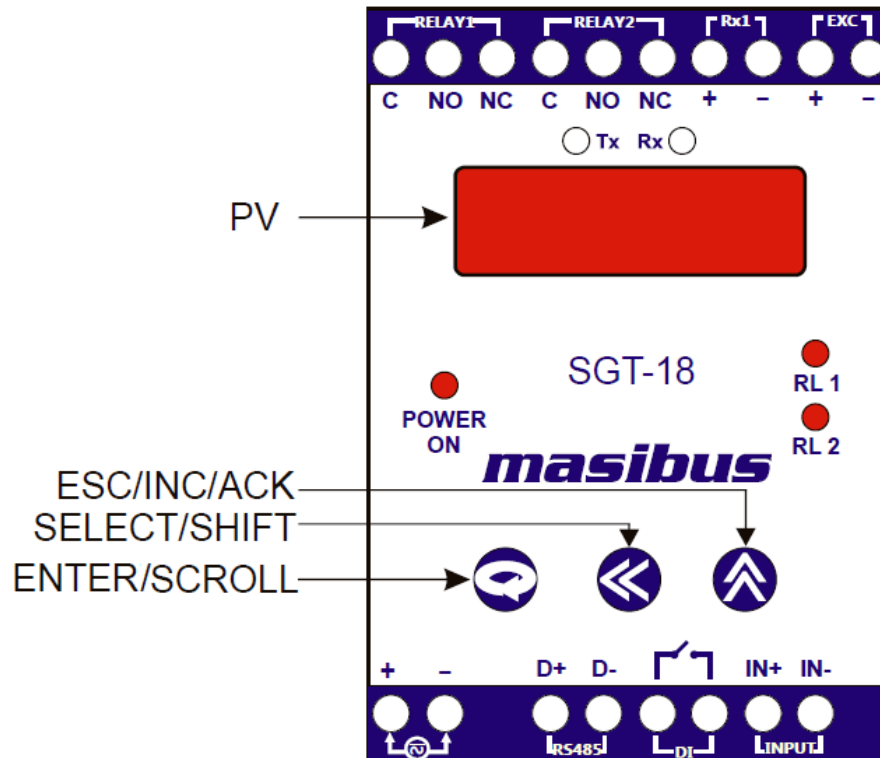

ENTER / SCROLL Key – This key is used to start menu, scroll through the menu and save values.

SEL / SHIFT Key – This key is used to select the menu options, for shifting the digit of the selected parameters and for Gross value display.

ESC / INC/ ACKNOWLEDGEMENT Key – This key is used to revert back to the parent menu from the sub menu levels and Increment the selected digit. This key is also used as Acknowledgement key for Alarm/trip type relay.

ENT+SHIFT Key – This simultaneous keys are used to check the mV feed in Unit.

ENT+INC Key – This simultaneous keys are used for TARE the weight.

4. Dimensions

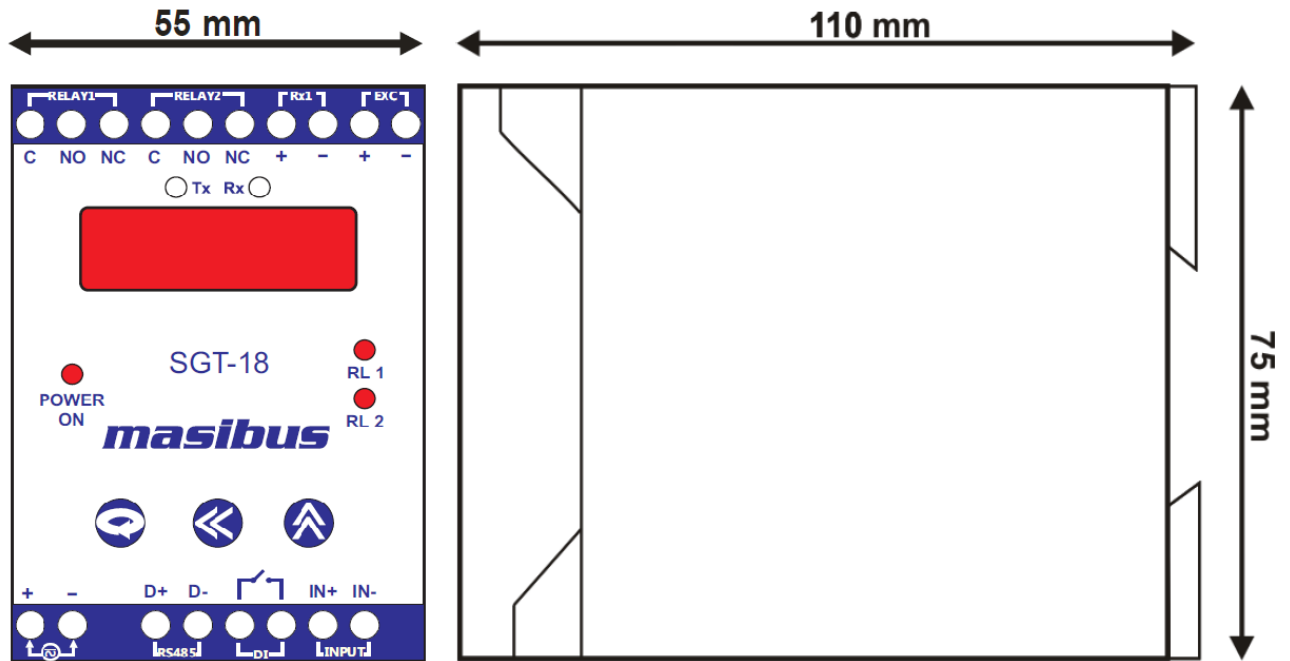

5. Terminal Position Detail:

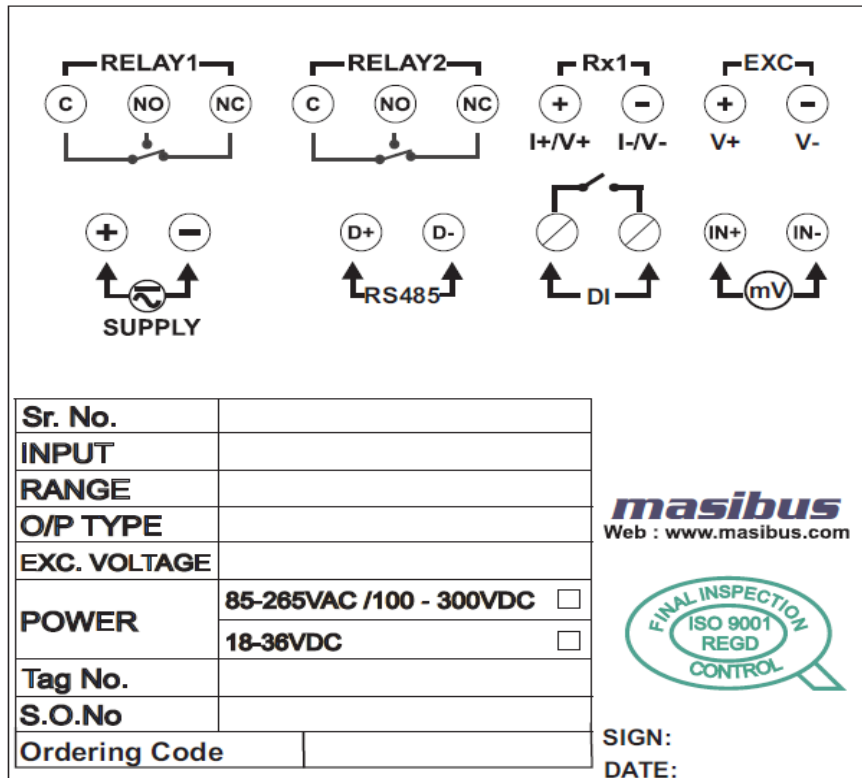

6. Menu Function List

P-00	St-1	Set point value for relay-1
	HY-1	0 TO 100
	St-2	Set point value for relay-2
	HY-2	0 TO 100

* Output will not be scaled but only limit to this configured % of output.

** Retransmission Output (0% to 100%) will be scaled according to value of O/P Zero and O/P Span.

CONF	INP	IPtY	mV(-10.00 to 99.99)	
		ZErO	Input Zero Value	
		SPAn	Input Span Value	
		dP	0 - 3	
		OFFt	For Offset Value	
		INLO	mV(-10.00 to 99.99)	
		INH I	INHI – INLO >5.00 mV	
	OUT	retr	re .oP	Retransmission Output Mapping: Net/Gross
			OPtY	4 –20mA, 0 –20mA, 1-5V, 0-5V, 0-10VDC
			OP 2	**Output for scaling
			OP 5	**Output for scaling
			OPLO	* % of Output (O/P Low limit will be limited to this configured 0-25 % of O/P Span)
			OPHI	* % of output (O/P Hi limit will be limited to this configured 75-100 % of O/P Span)
			OPSC	UPSC/DNSC
		d Ir	DIR/REV	
		reLY	rLNO	1, 2
			OPSE	UP,dw
			LOGC	HI,low
			C AL	ALARM,TRIP,OPEN
			LtCH	YES,NO
			r dLY	Relay Delay (0-100 Sec)
		COñ	SrNO	1-247
	bRUd		4800,9600,19200	
	ADu	F ILt	0 - 60 Sec	
		FSEt	Give Default password for factory settings	
		PASS	Change Password	
		S9rE	YES/NO	
		tOUt	10-300 SEC	
	CAL	INP	SPAN	
			ZErO	
OUT		OPNO	1	
		SPAN		
uEr	I			

7. Parameter Description

CONF	Configuration Mode
CAL 1	Calibration Mode
INP	Input type Parameter Settings
OUT	Output type Parameter Settings
Adv	Advance Parameter Settings
VER	Software Version
IPtY	Input Type
ZERO	Input Zero
SPAN	Input Span
dP	Decimal Point
OFFt	Offset
INLO	I/P LO
INH I	I/P HI
rt .oP	Retransmission Output Mapping
net	Net Value
Gross	Gross Value
OPtY	Output Type
OP 2	**Output for scaling
OP 5	**Output for scaling
OPLO	* % of the O/P Zero range
OPHI	* % of the O/P Span range
OPSC	Up/down Scale one sensor open
d Ir	Forward/Reverse Output
F ILt	Digital Filter
FSEt	Factory Setting
PASS	Password
Sqr t	Square root
tOUT	Time out From the Menu (10 to 300 Sec)
DUEr	Input Signal above Span
UNdr	Input Signal below Zero
OPEN	Sensor Burned
̄A It	Calibration In Process
FErr	Factory setting Error
rELY	Relay
rLNO	Relay number
OPSE	Open sensor
LOGC	Relay control Logic
C AL	Configure alarm
LtCH	Latch
r dLY	Relay Delay
rt r	Retransmission
SrNO	Serial No
bAUD	Baud Rate
St- 1	Set point for relay one
HY- 1	Hysteresis for Relay one
St- 2	Set point for Relay two
HY- 2	Hysteresis for Relay two

8. Menu Guideline

8.1 Program Menu

- Set point for relay-1.
- Hysteresis for relay-1.(0-100)
- Set point for relay -2.
- Hysteresis for relay-2.(0-100)

8.2 Configuration Menu

8.2.1 Input Selection

- Input Type Selection
- Input Zero Setting
- Input Span Setting
- Decimal Point Setting
- Offset Setting

8.2.2 Output Selection

8.2.2.1 Retransmission:-

- Retransmission Output Mapping
- Output Type Selection
- (0 –20 mA, 4-20 mA, 0-5 V, 1-5 V, 0 – 10 V that will be provided as factory setting)
- Output Zero Setting for scaling.
- Output Span Setting for scaling.
- Output Low Setting (Minimum 0.0 – 25.0 %)
- Output High Setting (Maximum 75.0 - 100.0 %)
- Output Upscale / Downscale Setting for OPEN input
- Output direction setting (Direct / Reverse)

8.2.2.2 Relay:-

- Relay No. Selection for setting purpose (1 or 2)
- Relay Upscale / Downscale Setting for OPEN input
- Selection for Operating relay above (high) or below (low) set point.
- Selection of relay type i.e. Alarm or Trip or Open.
- Latch selection whether “Latch yes” or “No Latch” only if alarm type relay is selected.
- Relay Delay is time to operate relay (In Seconds 0-100).

8.2.2.3 Communication:-

- Sr. No. Selection for setting purpose (1 to 247)
- Baud Rate Selection for Setting Purpose (4800, 9600, 19200)

8.2.3 Advance Options

- Digital filtering (Range: 0 to 60.0 second)
- Factory Setting- To retrieve the factory setting.
- Password Setting
- Square Root (No / YES, for Linear inputs only)
- For Square Root, Output will be come as per
- $PV = \text{SQRT} [\{ (\text{input reading} - \text{config. IP Zero}) / (\text{config. IP Span} - \text{Config. IP Zero}) \} * \text{Config. OP Span}] + \text{Config. OP Zero}$
- Time Setting for Come back to RUN mode on no key operation (Range: 10 to 300 second)

8.3 Calibration Menu

- **Input Calibration**
 - Input Zero Calibration
 - Input Span Calibration
- **Output Calibration**
 - Output Channel Selection for calibration
 - Output Zero Calibration
 - Output Span Calibration

8.4 Software Version

- Version Number of the Software

9. Menu Layout

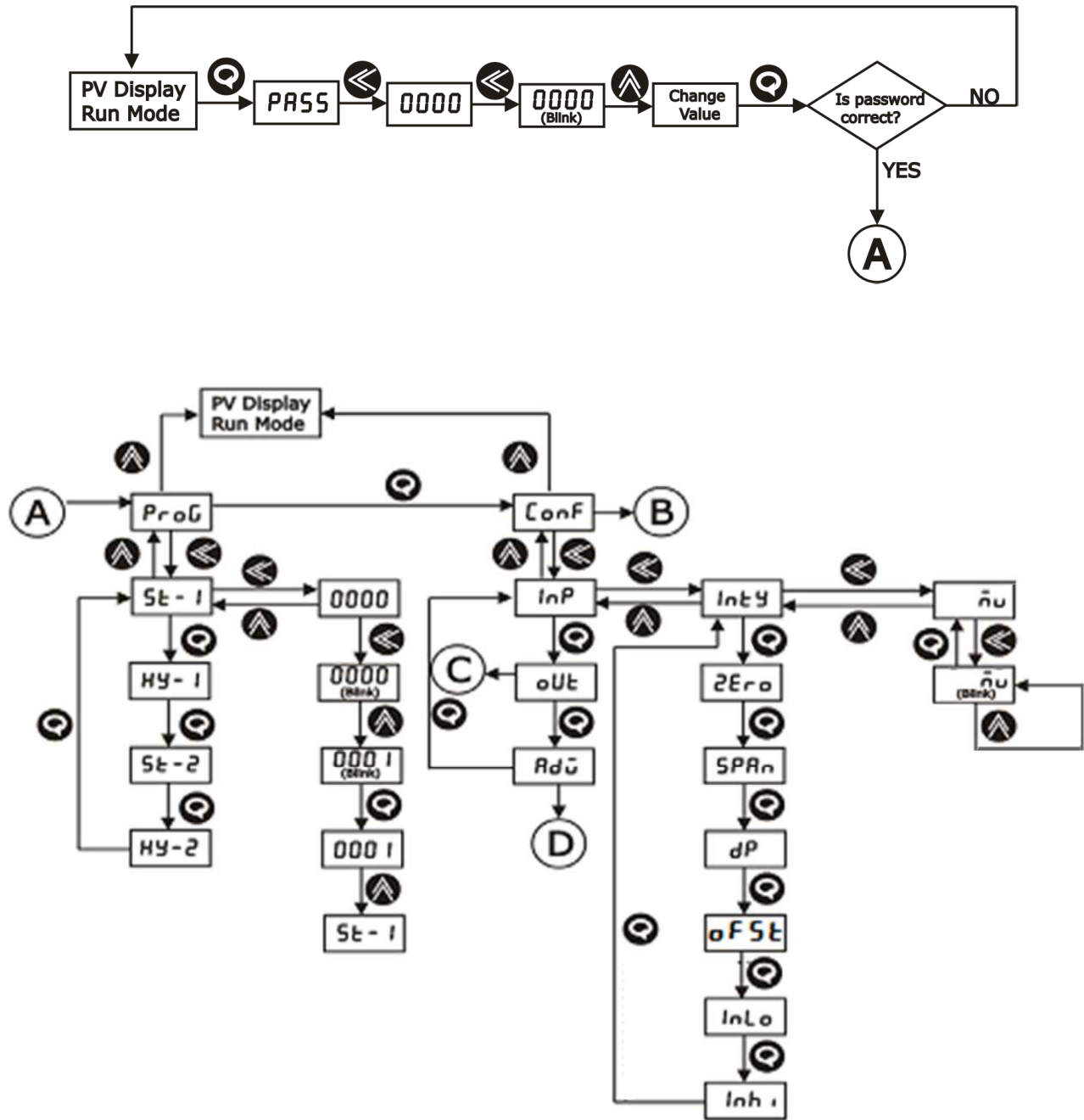

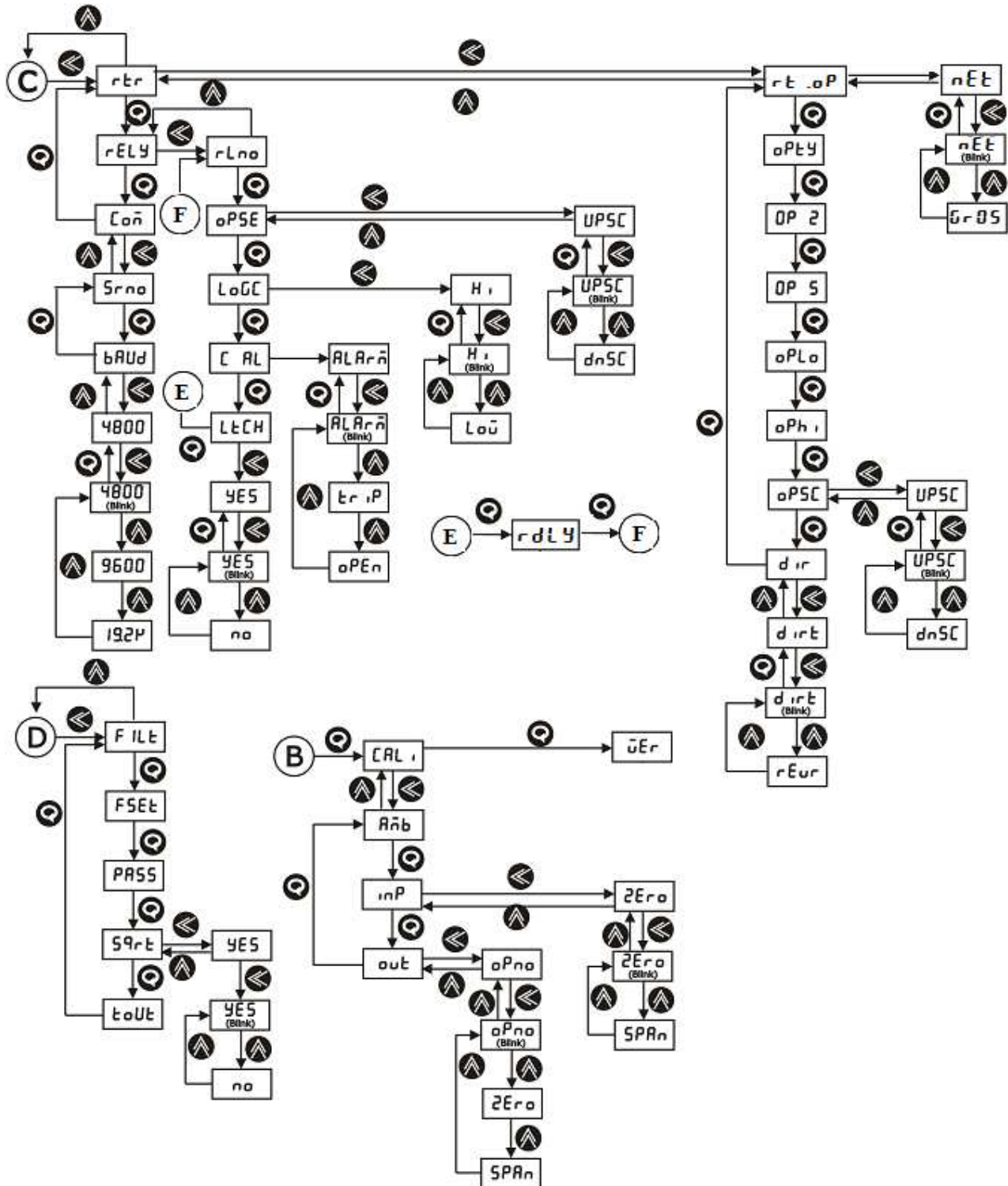

10. Modbus Detail:

The table show Analog data to be transmitted and its sequence.

10.1 Configuration parameter Read – write.

Sr. no	Analog Parameters	Absolute Address	Type of Access	Parameter Type	Values Applicable
1.	Set point for relay1	40001	Read/write	Int	
2.	Hysteresis for relay1	40002	Read/write	Int	0 - 100
3.	Set point for relay2	40003	Read/write	Int	
4.	Hysteresis for relay2	40004	Read/write	Int	0 - 100
5.	I/P type	40005	Read/write	Int	10
6.	I/P zero	40006	Read/write	Int	-1999 to 9999
7.	I/P span	40007	Read/write	Int	-1999 to 9999
8.	Decimal point	40008	Read/write	Int	0 - 3
9.	Offset	40009	Read/write	Int	As per Input Range
10.	I/P Lo mV	40010	Read/write	Int	-1000 to 9999
11.	I/P Hi mV	40011	Read/write	Int	-1000 to 9999
12.	O/P type1	40012	Read/write	Int	1 To 5
13.	O/P Zero* of O/P 1 for scaling	40013	Read/write	Int	As per Input Range
14.	O/P Span* of O/P 1 for scaling	40014	Read/write	Int	As per Input Range
15.	O/P Lo (% of O/P Zero range) for O/P1	40015	Read/write	Int	0-250
16.	O/P High (% of O/P Span range) for O/P1	40016	Read/write	Int	750-1000
17.	Open sensor for O/P1	40017	Read/write	Int	1 To 2
18.	Direction for O/P1	40018	Read/write	Int	3 To 4
19.	Retransmission Output Mapping (Net Value/Gross Value)	40019	Read/write	Int	1 To 2
20.	Relay Delay for Relay-1 (Sec)	40020	Read/write	Int	0-100
21.	Relay Delay for Relay-2 (Sec)	40021	Read/write	Int	0-100
22.	DI Input (Tare)	40022	Read/write	Int	0-1
23.	Reserved	40023	Read/write	Int	0
24.	Reserved	40024	Read/write	Int	0
25.	Reserved	40025	Read/write	Int	0
26.	Open sensor for relay1	40026	Read/write	Int	1 To 2
27.	Relay control logic for relay1	40027	Read/write	Int	1 To 2
28.	Configure alarm for relay1.	40028	Read/write	Int	1 To 3
29.	Latch for relay1	40029	Read/write	Int	1 To 2
30.	Open sensor for relay2	40030	Read/write	Int	1 To 2
31.	Relay control logic for relay2	40031	Read/write	Int	1 To 2
32.	Configure alarm for relay2	40032	Read/write	Int	1 To 3
33.	Latch for relay2	40033	Read/write	Int	1 To 2
34.	Slave ID	40034	Read/write	Int	1 - 247
35.	Baud rate	40035	Read/write	Int	1 To 3
36.	Digital filter	40036	Read/write	Int	0 - 60
37.	Password	40037	Read/write	Int	0 - 9999
38.	Square root	40038	Read/write	Int	1 - 2
39.	Time out from the menu	40039	Read/write	Int	10 - 300

*Retransmission Output (0% to 100%) will be scaled according to value of O/P Zero and O/P Span.

Note: The values for above configuration parameter are as follows:

- a) I/P Type:
 - mV - 10
- b) Ret. O/P:
 - Net - 1
 - Gross - 2
- c) O/P type:
 - 0-20 mA - 1
 - 4-20 mA - 2
 - 0-5 V - 3
 - 1-5 V - 4
 - 0-10 V - 5
- d) Open sensor for O/P:
 - Up - 1
 - Down - 2
- e) Direction for O/P:
 - Direct - 3
 - Reverse - 4
- f) Open sensor for relay:
 - Up - 1
 - Down - 2
- g) Relay control logic:
 - Hi - 1
 - Low - 2
- h) Configure alarm for relay:
 - Alarm - 1
 - Trip - 2
 - Open - 3
- i) Latch for relay:
 - Yes - 1
 - No - 2
- j) Baud rate:
 - 4800 - 1
 - 9600 - 2
 - 19200 - 3
- k) Square root:
 - No - 1
 - Yes - 2

10.2 Configuration parameter Read:

Sr. no	Analog Parameters	Absolute Address	Type of Access	Parameter Type
1	Net value	30001	Read	Int
2	Gross value	30002	Read	Int
3	mV value	30003	Read	Int

$$\text{Gross Value} = \text{I/P Feed mV} * \left(\frac{\text{I/P Span} - \text{I/P Zero}}{\text{InHI} - \text{InLO}} \right)$$

Net Value = Gross Value- Tare Value

Example: If Input Range is 0-80mV, then InLO will be 0 and InHI will be 80. If Scaled Display Range is 0-40Kg., then I/P Zero will be 0 and I/P Span will be 40.

If you feed input of 40mV then the Gross Value is as below:

$$\text{Gross Value} = 40 * \left(\frac{40-0}{80-0} \right)$$

$$\text{Gross Value} = 40 * 0.5$$

$$\underline{\text{Gross Value} = 20}$$

OFFSET Parameter is used to nullify the dead weight i.e. base plate weight to have actual measurement of material weight measurement. Once user enters the indicated bare weight into offset parameter, device will automatically nullify the weight of bare plate for actual measurement.

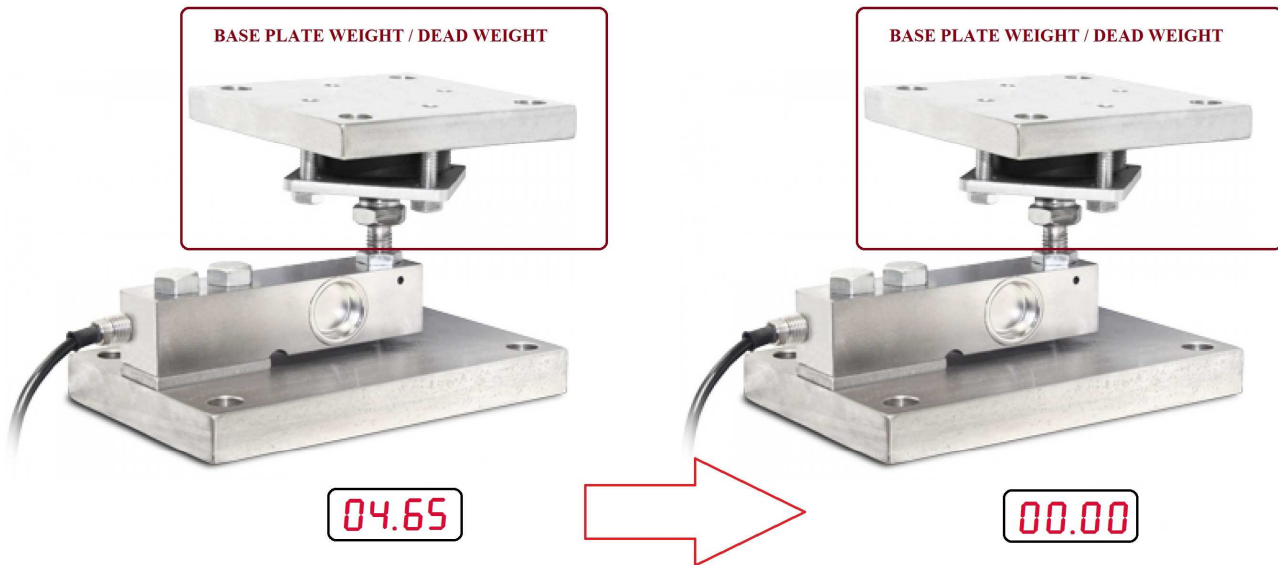

The above figure shows the example of **OFFSET** parameter. For example, at first instance, base plate weight (As shown in above figure) is 4.65Kg, that will be shown on PV Display of device. One can nullify this weight by adding value of 4.65 in **OFFSET** parameter. After adding this dead weight value, PV will now show the value 0 which means that now device is ready to measure actual weight of material.

Hence by use of **OFFSET** parameter, user can measure the actual weight by avoiding dead weight value of base plate.

Note:

- If SGT-18 process value is out of limit for particular I/P type then SGT-18 will show "Open" on display but it will send '32767' to Modbus
- The Modbus device ID no (Sr.no.) of SGT-18 Indicators must be within 001 to 247.
- Before starting the communication, match the Baud rate and Modbus device ID (Sr. no.) of Master and Slave devices.
- To clear the Tare Value manually, Enter 18 in FSET Menu.

11. Specifications

Input	
Input Type	-10.00 to 99.99mV field settable.
Display Range	-1999 to 9999
Accuracy	±0.1% of FS ±1 Digit
ADC Resolution	17 bits
Load Cell Excitation Voltage	5 to 15V DC factory set @ 100mA
Sampling Time	<75ms
Digital Input	Tare Adjustment
NMRR	>50 dB
CMRR	>120 dB
Tempo-Co	< 100ppm/°C
Max Voltage	20VDC
Display & Keys	
Process Value	0.3" Four-digit Seven segment, RED LED
Status Indication	Power, RL1, RL2, Tx, Rx
Keys	3 Keys for configuration, calibration and operation
Display Parameter	Gross or NET value field settable
Output	
Relay (Optional)	
Alarm output	2 nos
Type	Single change over (C, NO, NC)
Rating	2A @ 230VAC / 30VDC
Retransmission	
Output Signal	4-20mA/ 0-20mA/1-5VDC/ 0-5VDC/0-10V DC (any one - Factory Set)
Load Resistance	For Current o/p: < 750Ω max For Voltage o/p: > 4KΩ min
Output Accuracy	±0.25% of span
Temp-co	< 150ppm/°C
Communication (Optional)	
Interface	RS485 (2 Wire)
Protocol	Modbus-RTU
Baud rate	4800, 9600, 19200
Power Supply	
Voltage	85 - 265V AC, 50/60 Hz / 100-300VDC optional 18-36 V DC
Power consumption	<10VA
Isolation (Withstanding voltage)	
<ul style="list-style-type: none"> • Between primary terminals* and secondary terminals**: At least 1500 V AC for 1 minute • Between primary terminals*: At least 1500 V AC for 1 minute • Between secondary terminals**: At least 1500 V AC for 1 minute • * Primary terminals indicate power terminals and Aux Supply terminals. • ** Secondary terminals indicate I/O terminals and Communication O/P. Insulation resistance: 20MΩ or more at 500 V DC between power terminals and grounding Terminal	

Physical

Dimension in mm	75(H) x 55(W) x 110(D)
Mounting	Din Rail
Weight Approx.	< 250 grams
Enclosure material	ABS
Enclosure Protection	IP20
Terminal Cable Size	2.5mm ²

Environmental

Ambient temperature	0 to 55°C
Storage Temperature	0 to 80°C
Humidity	20% to 95% RH (Non-Condensing)

Connection Diagram

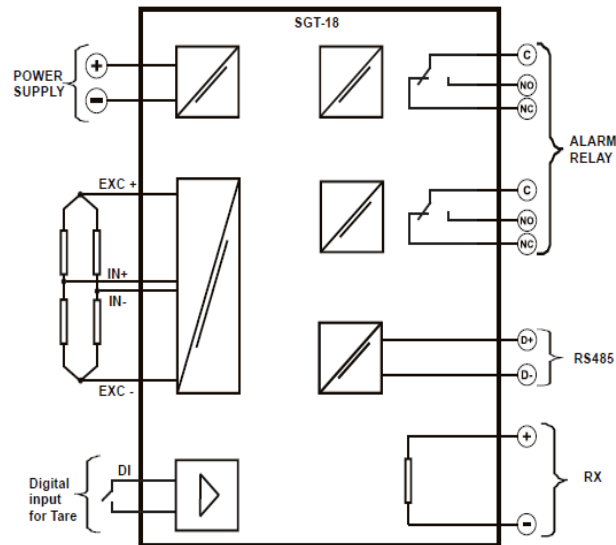

12. Relay Logic:

Without acknowledge key pressed									
CONDITION	ALARM LATCH/TRIP	RELAY/LED	NORMAL	ABNORMAL	UP	DOWN	ACK IN ABNORMAL CONDITION	NORMAL	ACK IN NORMAL CONDITION
HIGH	ALARM LED LATCH YES	LED	OFF	FLASH	FLASH	OFF	-	STEADY	OFF
		RELAY	OFF	ON	ON	OFF	-	OFF	OFF
	ALARM LED LATCH NO	LED	OFF	FLASH	FLASH	OFF	-	OFF	OFF
		RELAY	OFF	ON	ON	OFF	-	OFF	OFF
	TRIP	LED	OFF	FLASH	OFF	OFF	-	STEADY	OFF
		RELAY	OFF	ON	OFF	OFF	-	ON	OFF
LOW	ALARM LED LATCH YES	LED	OFF	FLASH	OFF	FLASH	-	STEADY	OFF
		RELAY	OFF	ON	OFF	ON	-	OFF	OFF
	ALARM LED LATCH NO	LED	OFF	FLASH	OFF	FLASH	-	OFF	OFF
		RELAY	OFF	ON	OFF	ON	-	OFF	OFF
	TRIP	LED	OFF	FLASH	OFF	OFF	-	STEADY	OFF
		RELAY	OFF	ON	OFF	OFF	-	ON	OFF
With acknowledge key pressed									
CONDITION	ALARM LATCH/TRIP	RELAY/LED	NORMAL	ABNORMAL	UP	DOWN	ACK IN ABNORMAL CONDITION	NORMAL	ACK IN NORMAL CONDITION
HIGH	ALARM LED LATCH YES	LED	OFF	FLASH	FLASH	OFF	STEADY	STEADY	OFF
		RELAY	OFF	ON	ON	OFF	OFF	OFF	OFF
	ALARM LED LATCH NO	LED	OFF	FLASH	FLASH	OFF	STEADY	OFF	OFF
		RELAY	OFF	ON	ON	OFF	OFF	OFF	OFF
	TRIP	LED	OFF	FLASH	OFF	OFF	STEADY	STEADY	OFF
		RELAY	OFF	ON	OFF	OFF	ON	ON	OFF
LOW	ALARM LED LATCH YES	LED	OFF	FLASH	OFF	FLASH	STEADY	STEADY	OFF
		RELAY	OFF	ON	OFF	ON	OFF	OFF	OFF
	ALARM LED LATCH NO	LED	OFF	FLASH	OFF	FLASH	STEADY	OFF	OFF
		RELAY	OFF	ON	OFF	ON	OFF	OFF	OFF
	TRIP	LED	OFF	FLASH	OFF	OFF	STEADY	STEADY	OFF
		RELAY	OFF	ON	OFF	OFF	ON	ON	OFF

Table 1

Note: If open type relay is selected then relay and LED will be ON when OPEN condition, while it will remain off if not in OPEN condition.

13. Appendix:

13.1 Internal Jumper Setting For Retransmission Output

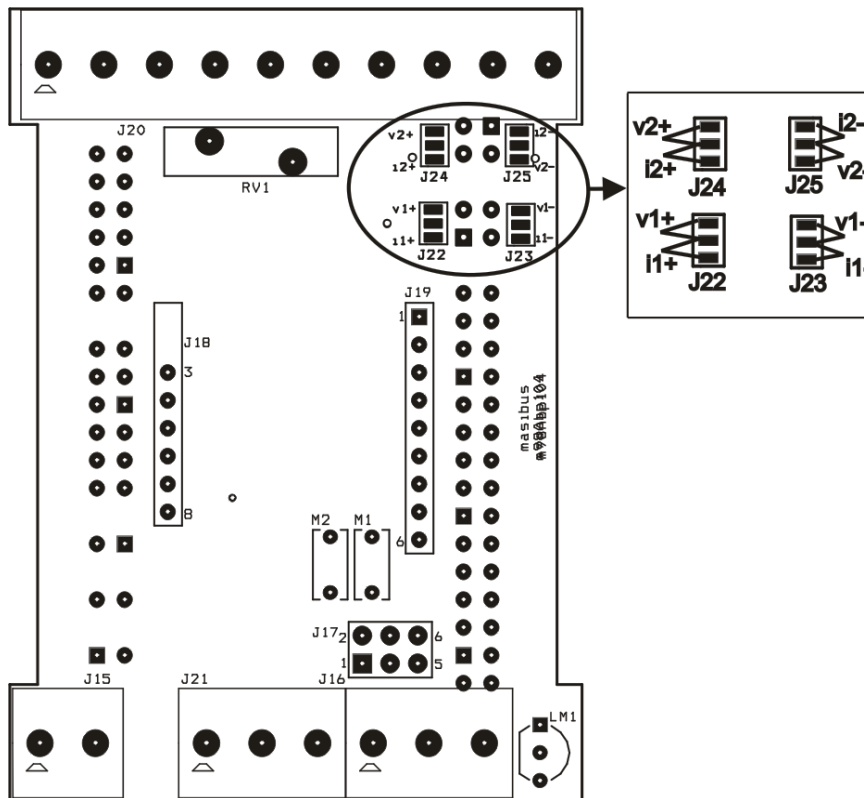

For retransmission output voltage or current, connect jumper as shown above on back plate PCB.

Static discharge will cause damage to equipment. Always ground yourself with wrist grounding strap when handling electronics to prevent static dis-charge.

14. Troubleshooting:

For primary troubleshooting of instrument use following procedure:

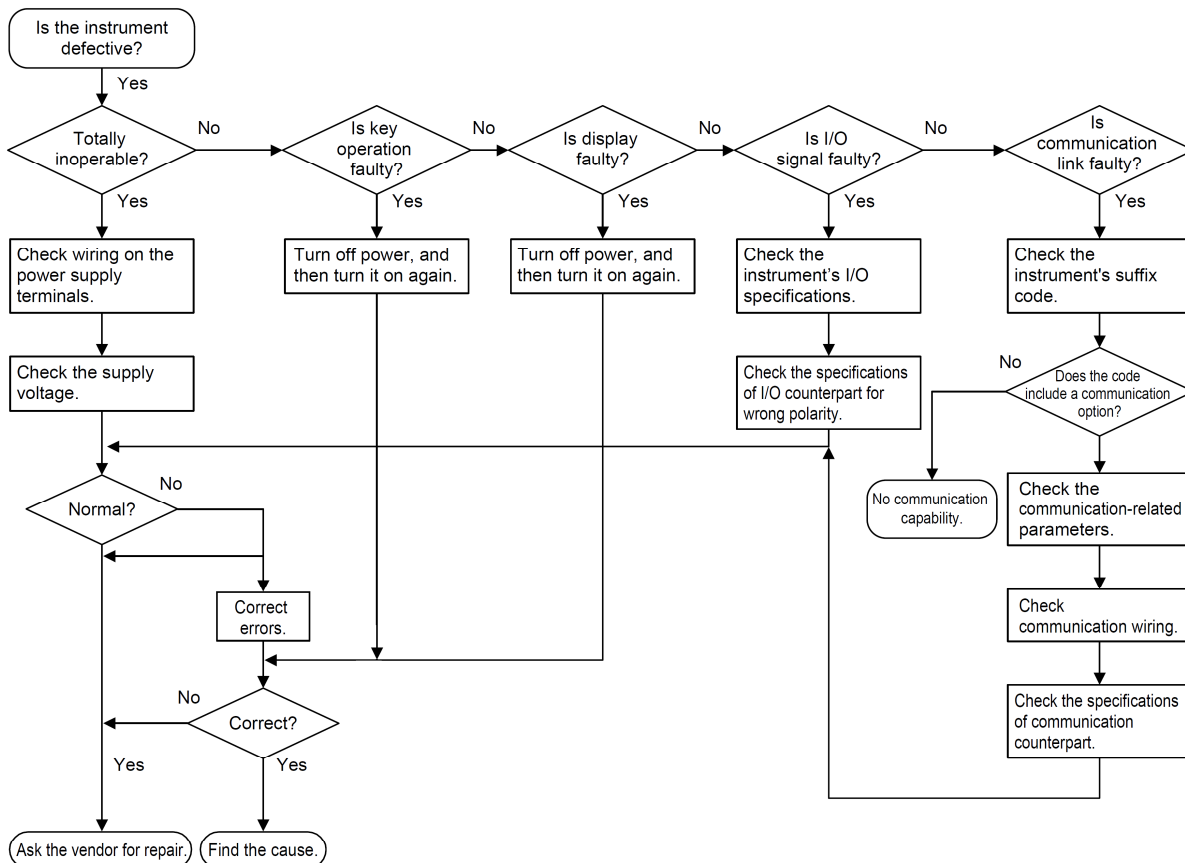

15. Load connection

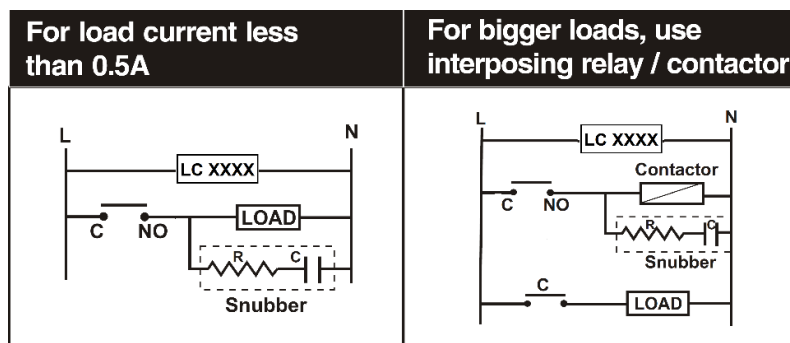

Electrical precautions during use

Electrical noise generated by switching of inductive loads can create momentary disruption, erratic display, latch up, data loss or permanent damage to the instrument. Use of snubber circuits across loads as shown above, is recommended.